

- 1.0 GENERAL NOTES
  - 1.1 ALL METRIC DIMENSIONS ARE IN BRACKETS [X.X]
  - 1.2 FOR PATENT INFO: <https://www.cs-pat.com>
- 2.0 DESIGN NOTES
  - 2.1 ANY HAZARDS OR OBSTRUCTIONS TO THE CLIMBING FACILITY AND SAFETY CLIMB MUST BE IDENTIFIED PRIOR TO INSTALLING THE APPURTENANCE. ADDITIONAL PRODUCTS MAY BE REQUIRED TO MAINTAIN THE INTEGRITY OF THE SAFETY CLIMB. DURING INSTALLATION, TEMPORARY AND/OR PERMANENT PRECAUTIONARY MEASURES SHOULD BE TAKEN TO PRESERVE THE CLIMBING FACILITY AND/OR SAFETY CLIMB.
- 3.0 MANUFACTURING/SPECIAL REQUIREMENTS
  - 3.1 TIGHTEN ALL BOLTS SECURING FLAT PLATES BY THE TURN-OF-NUT METHOD. TIGHTEN ALL U-BOLTS USING TURN-OF-NUT METHOD WITH ATTENTION TO LEAVE EQUAL DISTANCE AND EQUAL FORCE ON EACH LEG OF THE U-BOLT.
- 4.0 TEST
- 5.0 PACKAGING
  - 5.1 PACKAGING SHALL MEET COMMSCOPE REQUIREMENTS PER DOCUMENT IS-PL-3005
  - 5.2 PRINTED DOCUMENT TO BE PLACED INSIDE POLYBAG AND THEN IN SHIPPING CONTAINER
  - 5.3 EXTRA HARDWARE MAY BE SUPPLIED, BAGGED AND SHIPPED

| REVISIONS |                 |                   |                       |
|-----------|-----------------|-------------------|-----------------------|
| REV.      | DESCRIPTION     | DATE              | APPROVED              |
| A         | INITIAL RELEASE | RY1002<br>28MAR24 | YW1047<br>40191985CMO |

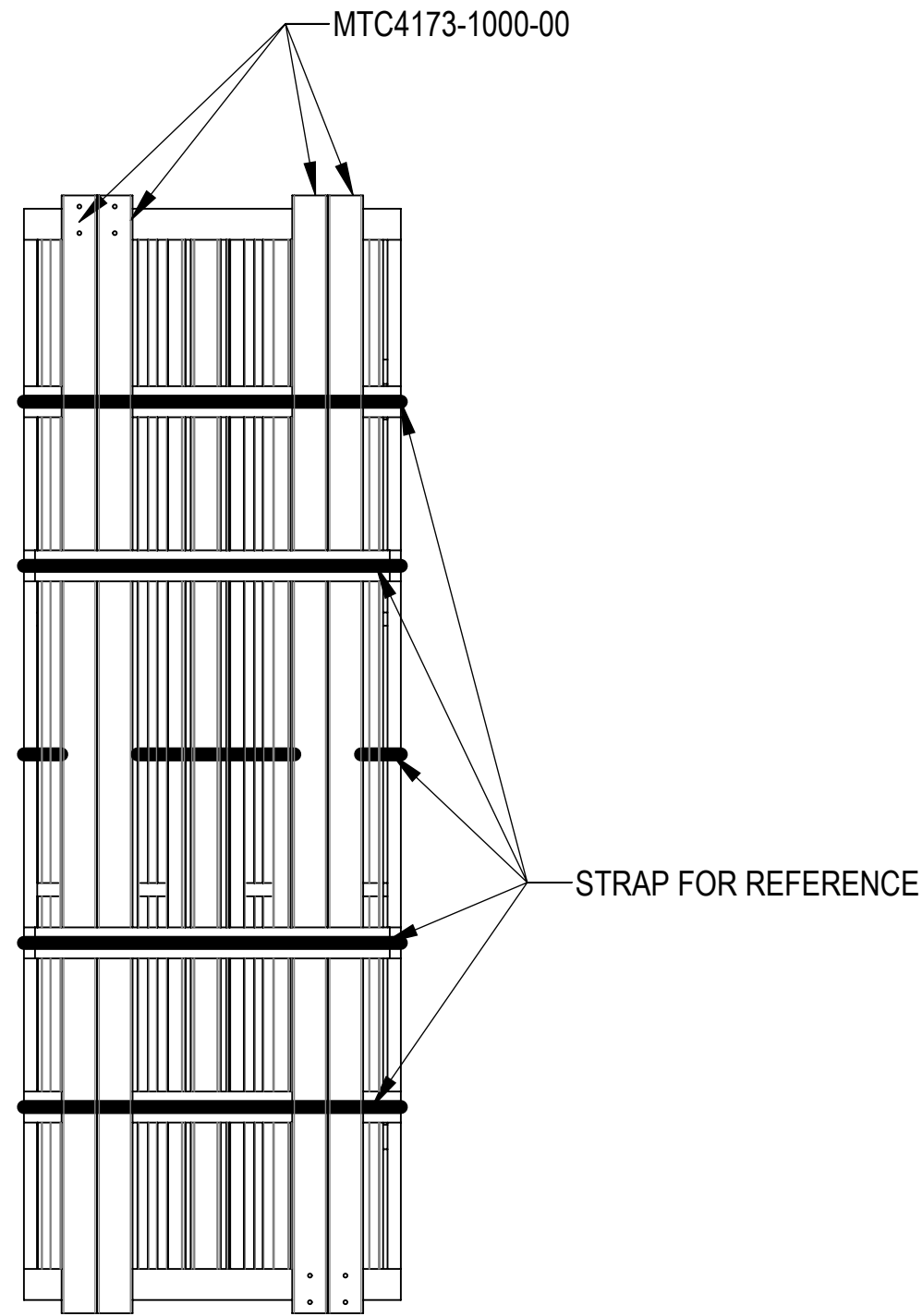

BOTTOM VIEW

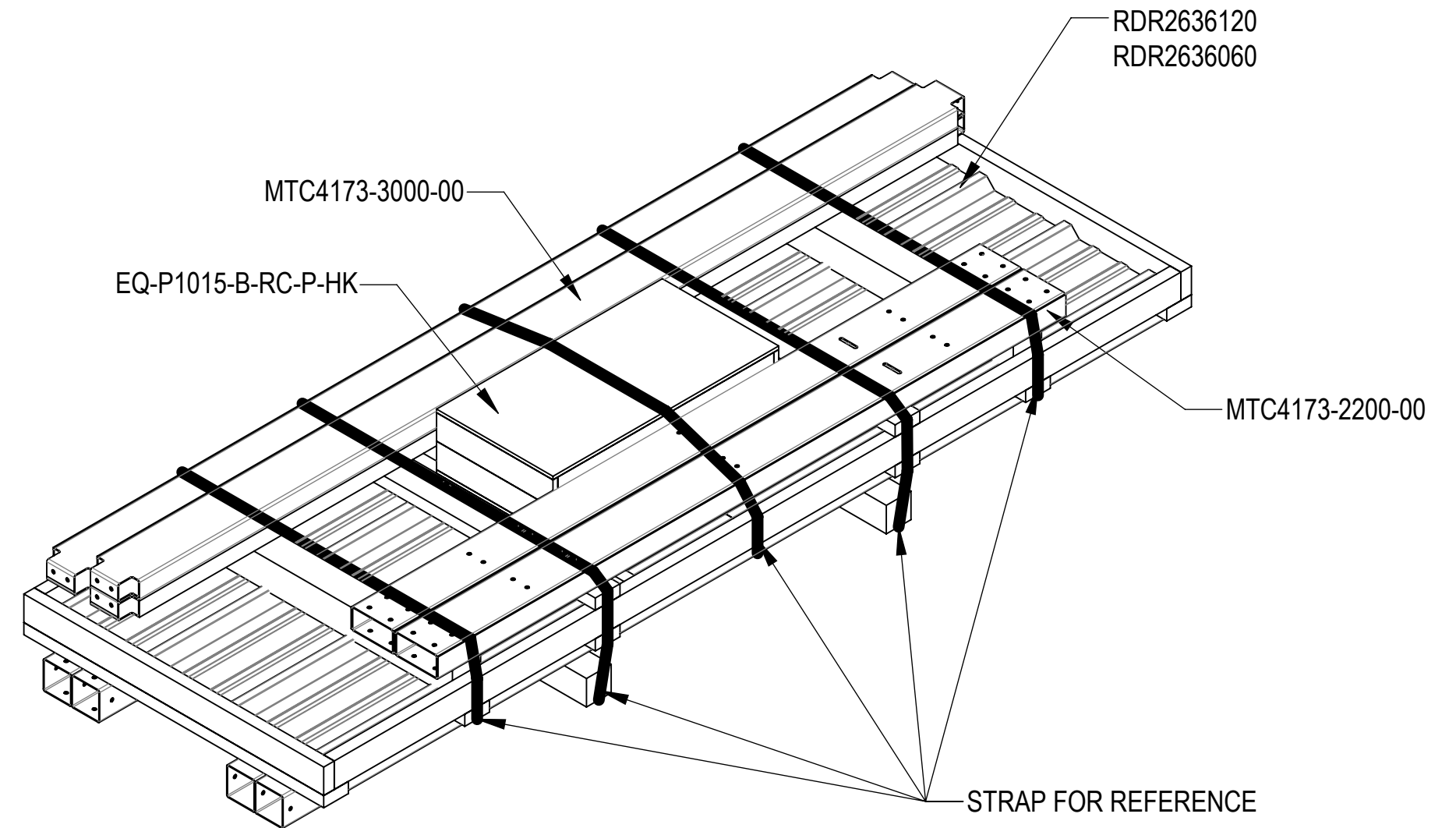

PACKAGE

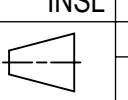
|   |  |   |                              |   |                        |   |  |  |         |  |
|---|--|---|------------------------------|---|------------------------|---|--|--|---------|--|
| <b>COMMSCOPE, INC. OF NORTH CAROLINA</b>  |  |   |                              |   |                        |   |  |  |         |  |
| TOLERANCES  |  |   |                              |   | SAP MATERIAL MASTER    |   |  |  |         |  |
| 1 PLACE .X[X] ± 0.2[6.3]  |  |   | 3 PLACE .XXX[X] ± 0.060[1.5] |   | <b>EQ-P1015-B-RC-P</b> |   |  |  |         |  |
| 2 PLACE .XX[X] ± 0.12[3.0]  |  |   | ANGLES ± 2°                  |   |                        |   |  |  |         |  |
| FINISH  |  |   |                              |   | MATERIAL               |   |  |  |         |  |
| UNLESS OTHERWISE SPECIFIED DIMENSIONS ARE IN INCHES INTERPRET PER ANSI Y 14.5M-1994 |  |   |                              |   |                        |   |  |  |         |  |
|   |  | NAME  |                              | DATE  |                        | TITLE                                       |  |  |         |  |
| CE  |  | RY1002  |                              | 09APR24   |                        | <b>10'X15' RAIN CANOPY, ON EQ. PLATFORM</b> |  |  |         |  |
| RW  |  | RY1002  |                              | 04/28/2024  |                        |   |  |  |         |  |
| AD  |  | YW1047  |                              | 05/05/2024  |                        |   |  |  |         |  |
| RE  |  | YMENG   |                              | 05/05/2024  |                        |   |  |  |         |  |
| ECN   |  | 40191985CMO   |                              |   |                        |   |  |  |         |  |
| SCALE   |  |   | DOCUMENT NO.                 |   |                        |   |  |  |         |  |
| <b>1:24</b>   |  |   | <b>EQ-P1015-B-RC-P</b>       |   |                        |   |  |  |         |  |
| SIZE  |  | Auth Group  |                              | INSL  |                        | MODEL                                       |  |  | DRAWING |  |
| <b>C</b>  |  |  |                              |  |                        | VERSION                                     |  |  | STATUS  |  |
|   |  |   |                              |   |                        | 00  |  |  | RE      |  |
|   |  |   |                              |   |                        | A   |  |  | 00      |  |
|   |  |   |                              |   |                        | RE  |  |  | A       |  |
|   |  |   |                              |   |                        |   |  |  | SHEET   |  |
|   |  |   |                              |   |                        |   |  |  | 1 OF 4  |  |

|              |           |                     |
|--------------|-----------|---------------------|
| DENSITY      |           | lbs/in <sup>3</sup> |
| MASS         | 978.42    | lbs                 |
| VOLUME       | 3455.44   | in <sup>3</sup>     |
| SURFACE AREA | 106959.56 | in <sup>2</sup>     |
| HEIGHT       | 139.8"    |                     |
| LENGTH       | 180.5"    |                     |
| WIDTH        | 125.6"    |                     |

4

3

2

1

D

D

C

C

B

B

A

A

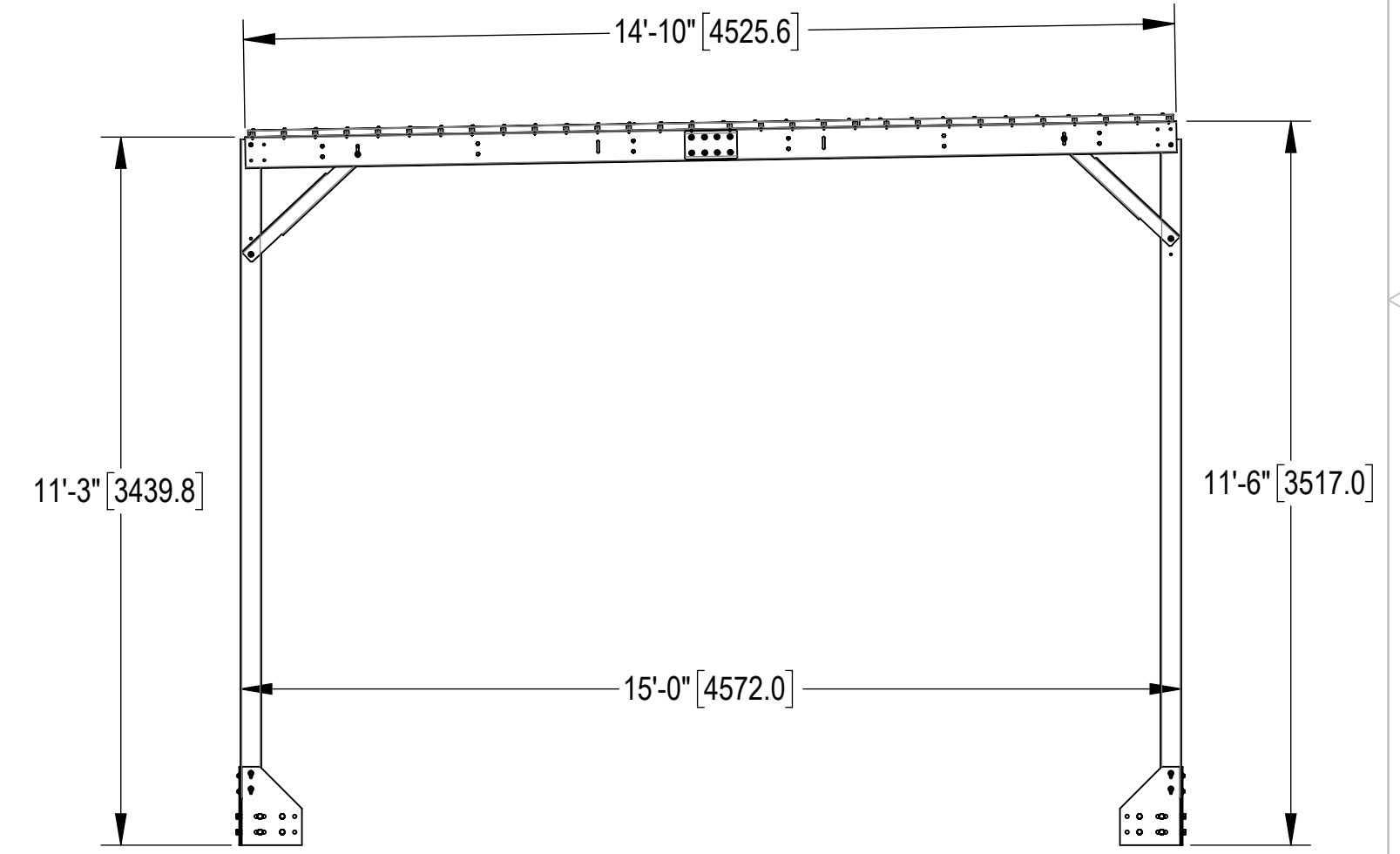
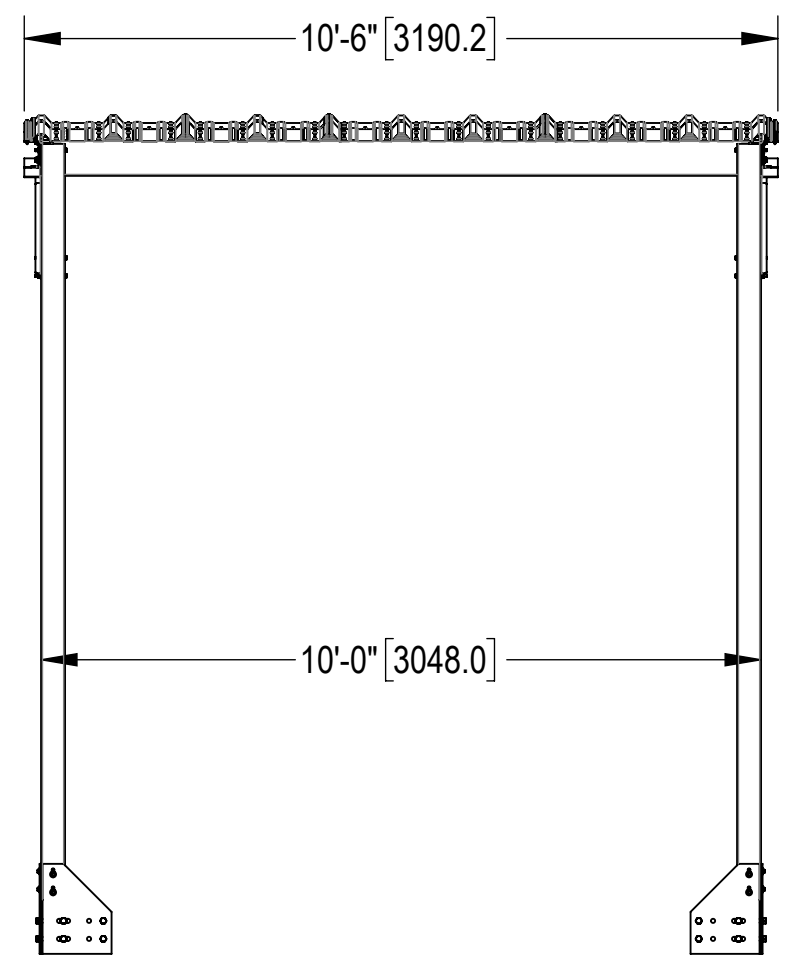
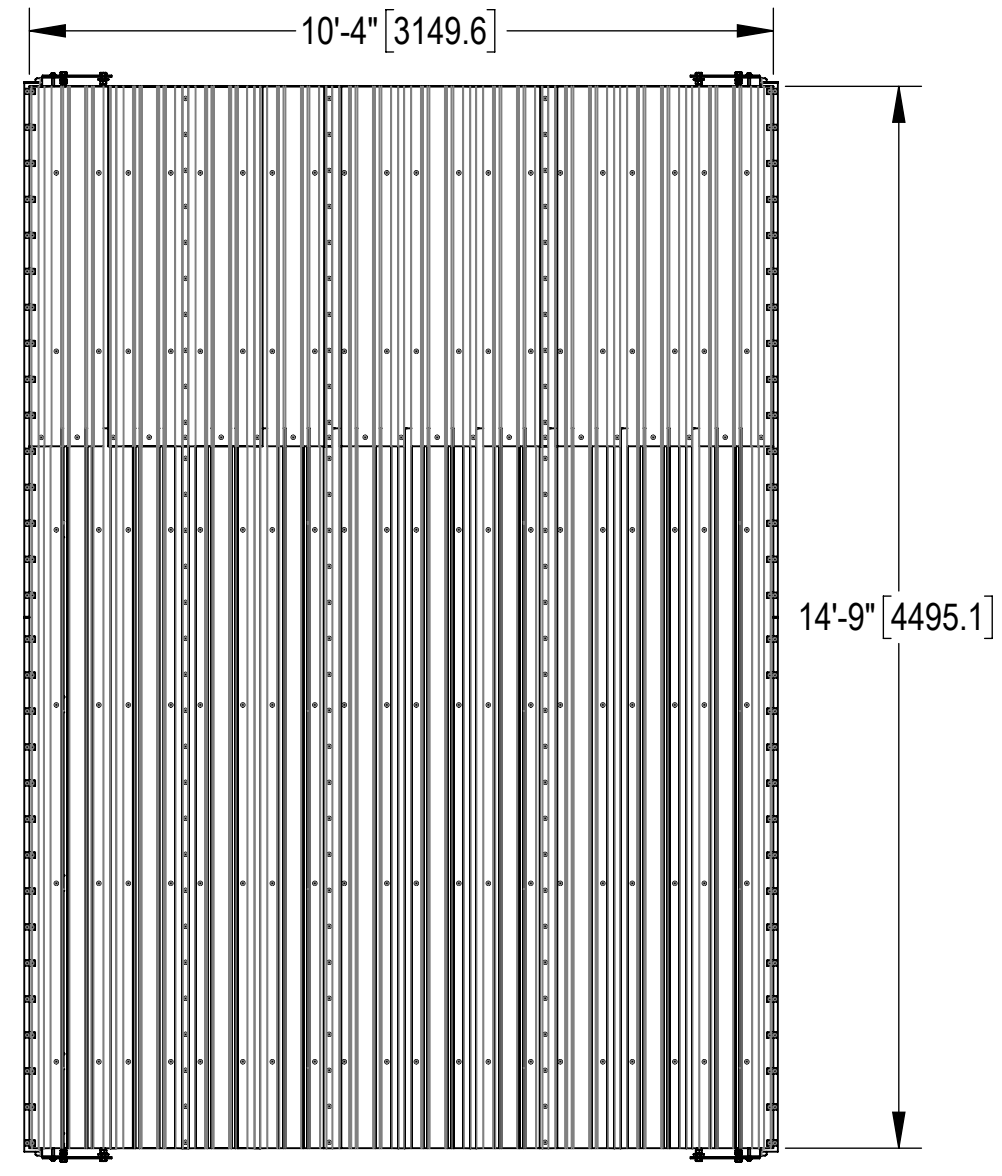
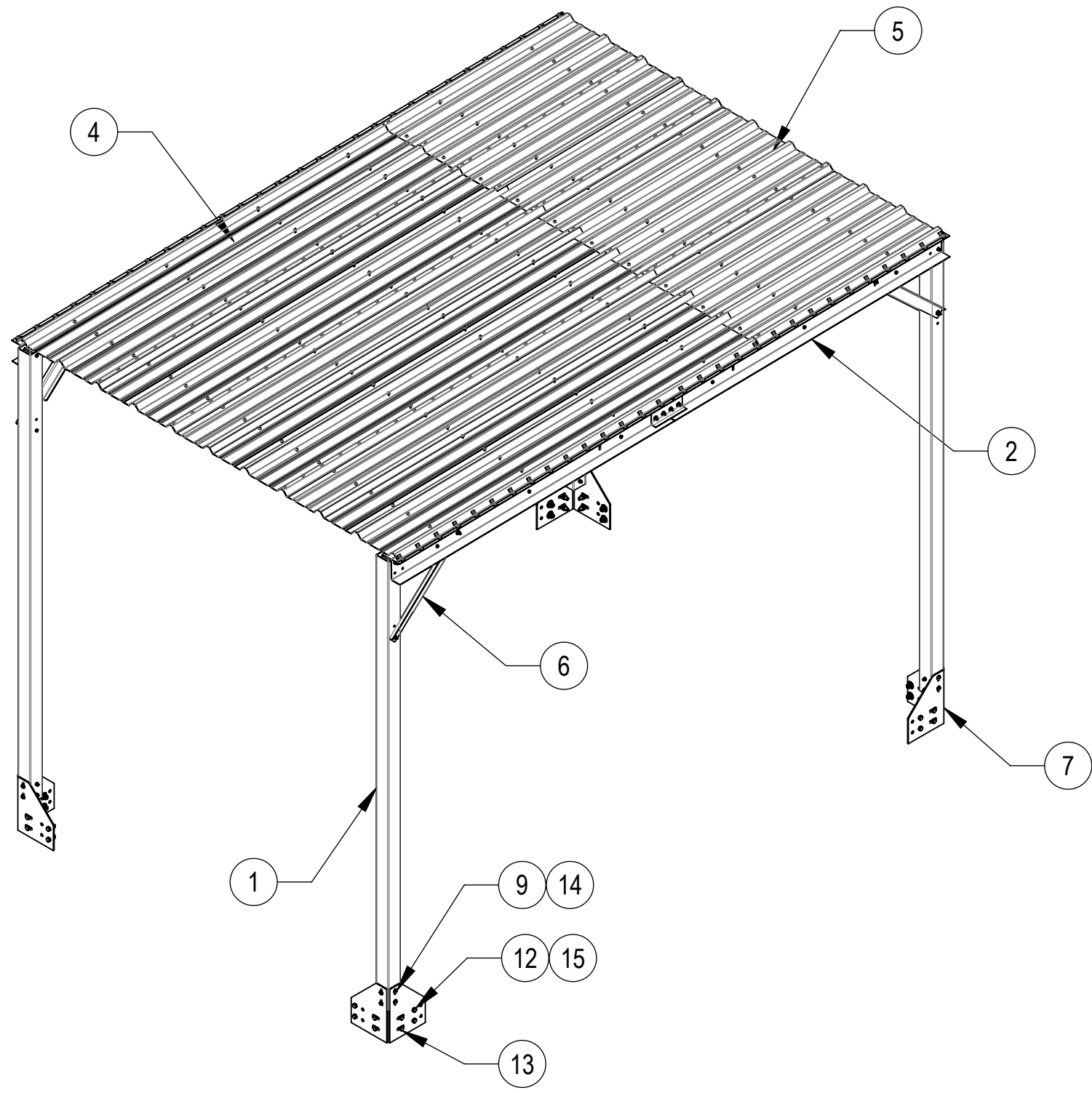

COMPONENT PART NUMBERS PROVIDED FOR ASSEMBLY PURPOSES;  
INDIVIDUAL COMPONENTS MAY BE SHIPPED AS PARTS WITHIN AN INCLUDED KIT.

| ITEM | PART NO.        | DESCRIPTION                               | QTY. | WEIGHT    | NOTE NO. |
|------|-----------------|---|------|-----------|----------|
| 1    | MTC4173-1000-00 | POST, 4X4 SQUARE TUBE, 126"               | 4    | 64.74 LBS |          |
| 2    | MTC4173-2200-00 | OUTER CHANNEL, ROOF SUPPORT               | 4    | 33.47 LBS |          |
| 3    | MTC4173-3000-00 | CANOPY CENTER CHANNEL                     | 6    | 42.80 LBS |          |
| 4    | RDR2636120      | ROOF DECKING PBR 26 GA 36" X 120"         | 4    | 29.65 LBS |          |
| 5    | RDR2636060      | ROOF DECKING PBR 26 GA 36" X 60"          | 4    | 17.72 LBS |          |
| 6    | MTC4130-3000-00 | CANOPY BRACE                              | 4    | 6.52 LBS  |          |
| 7    | MTC4169-2000-00 | PLATE, CANOPY LEG SUPPORT                 | 8    | 9.59 LBS  |          |
| 8    | MTC4173-4000-00 | OUTER CONNECTION CHANNEL                  | 2    | 2.60 LBS  |          |
| 9    | GB-03505        | 3/8" X 5" GALV BOLT KIT                   | 24   | 0.17 LBS  |          |
| 10   | GB-03125        | 3/8" X 1-1/4" GALV BOLT KIT               | 4    | 0.06 LBS  |          |
| 11   | GB-03105        | 3/8" X 1" GALV BOLT KIT                   | 40   | 0.05 LBS  |          |
| 12   | GB-05165        | 5/8" X 1-3/4" GALV BOLT KIT               | 16   | 0.24 LBS  |          |
| 13   | GB-05225        | 5/8" X 2-1/4" GALV BOLT KIT               | 16   | 0.28 LBS  |          |
| 14   | GWF-03          | 3/8" GALV FLAT WASHER                     | 44   | 0.01 LBS  |          |
| 15   | GWF-05          | 5/8" GALV FLAT WASHER, 1.70D              | 16   | 0.06 LBS  |          |
| 16   | MTC3799C26      | CLIP, RDR PANEL                           | 60   | 0.05 LBS  |          |
| 17   | TS1275          | TEK SCREW #12 X 3/4, WITH NEOPRENE WASHER | 180  | 0.02 LBS  |          |
| 18   | MTC371531       | 1/4-14X7/8 SELF DRILLING HEX HEAD SCREW   | 171  | 0.02 LBS  |          |

|   |               |                                 |        |          |
|---|---------------|---------------------------------|--------|----------|
| COMMSCOPE, INC. OF NORTH CAROLINA             |               |                                 |        |          |
| TITLE<br>10'X15' RAIN CANOPY, ON EQ. PLATFORM |               |                                 |        |          |
| SIZE<br>C                                     | SCALE<br>1:32 | DOCUMENT NO.<br>EQ-P1015-B-RC-P |        |          |
| DRAWING                                       |               | VERSION                         | STATUS | REVISION |
| SHEET<br>2 OF 4                               |               | 00                              | RE     | A        |

© 2024 CommScope, Inc. Confidential

4

3

2

1

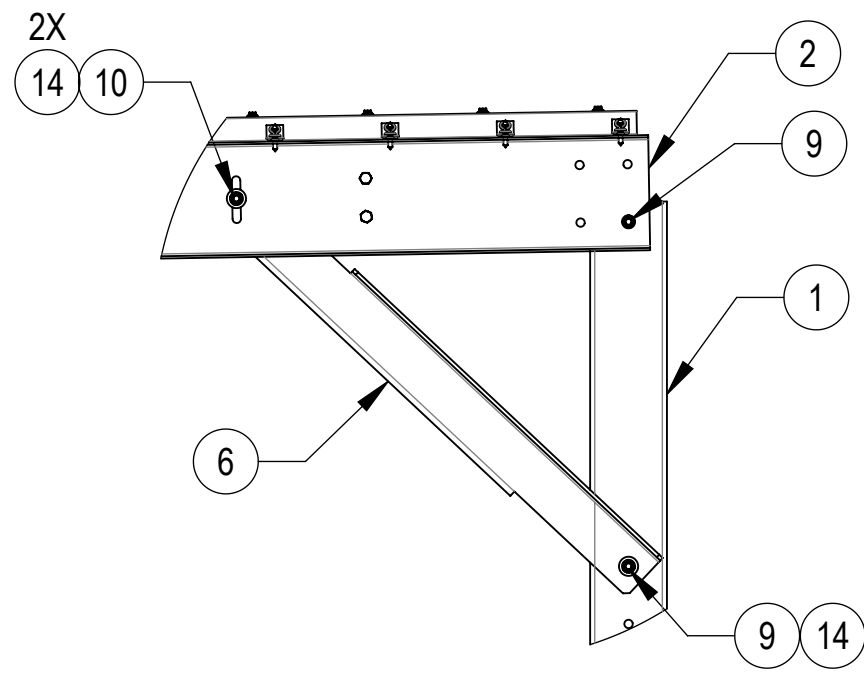
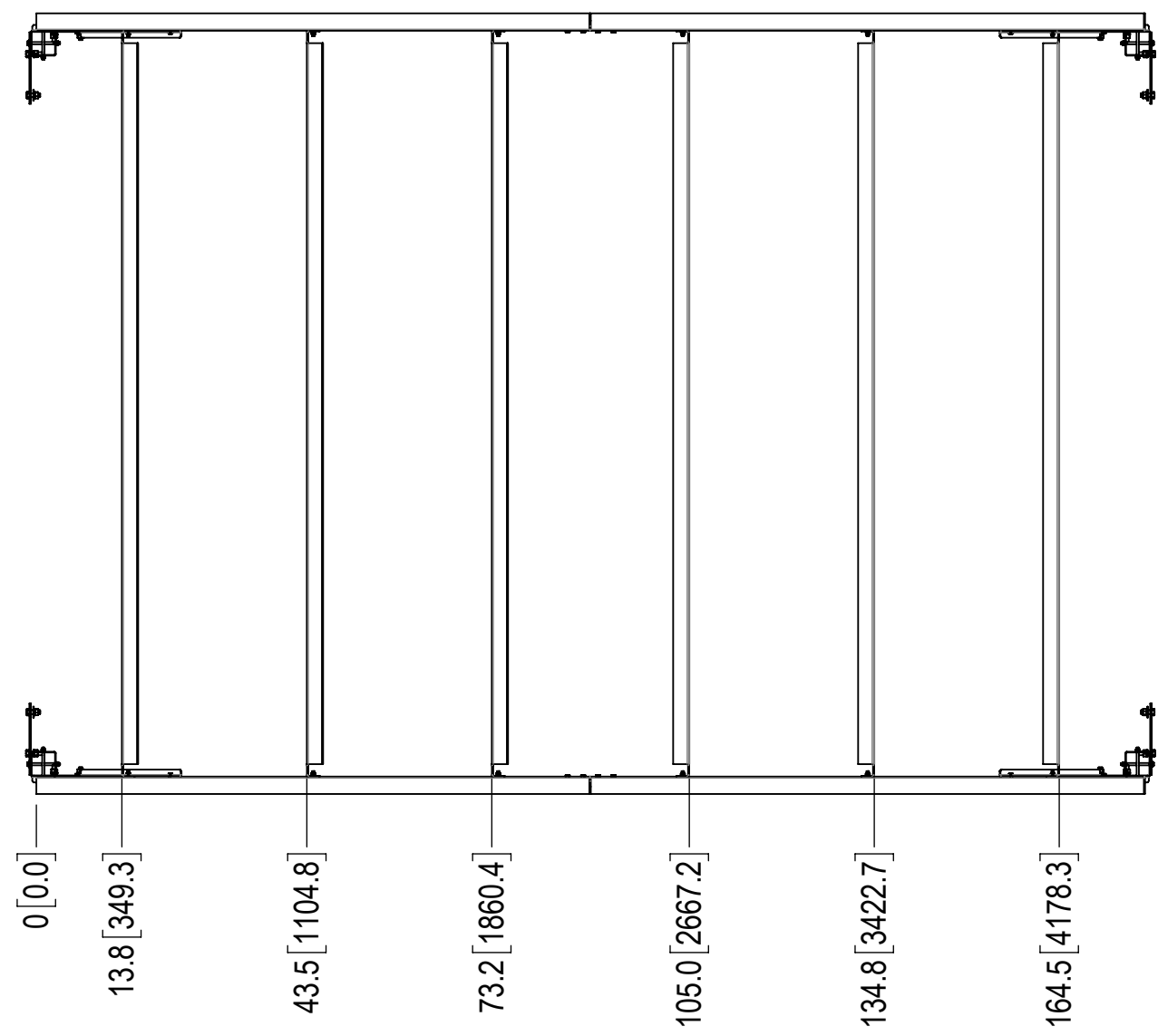

DETAIL A  
SCALE 1 : 10

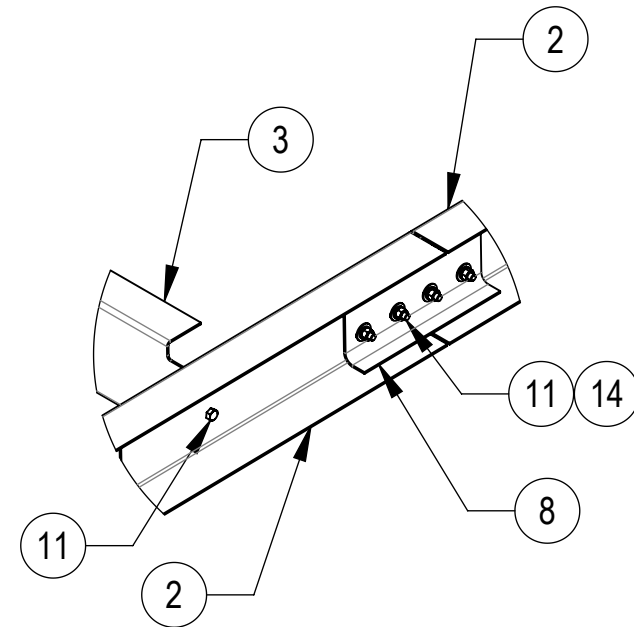
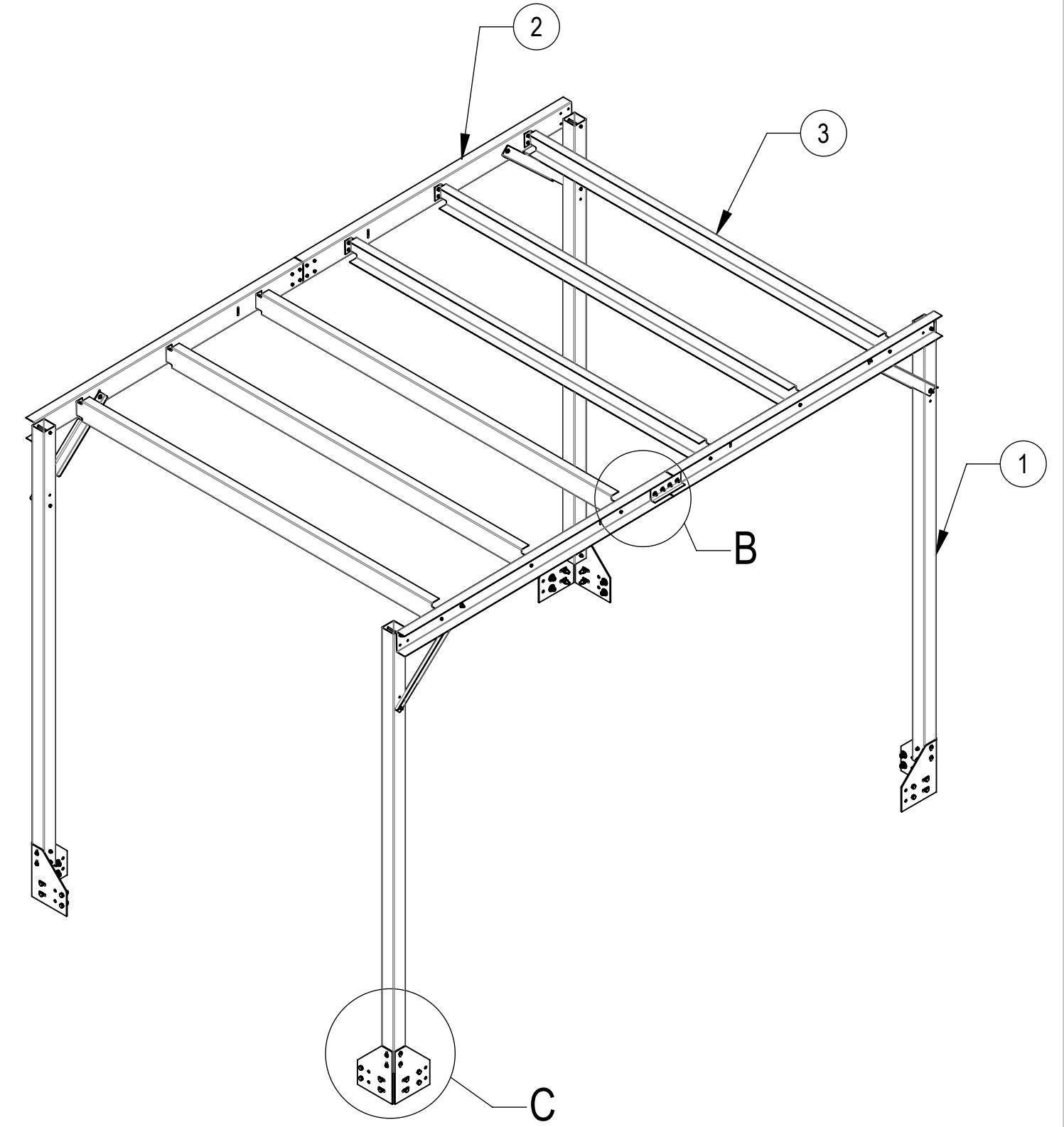

DETAIL B  
SCALE 1 : 10

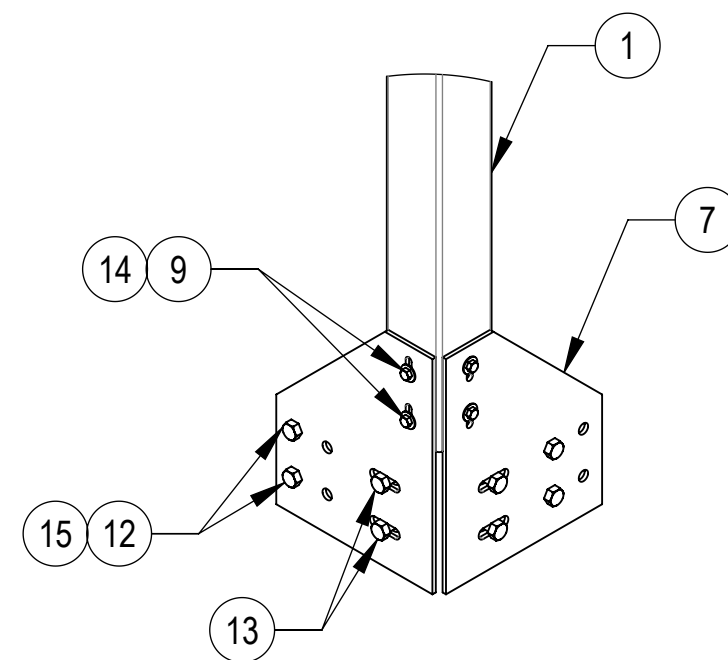

DETAIL C  
SCALE 1 : 10

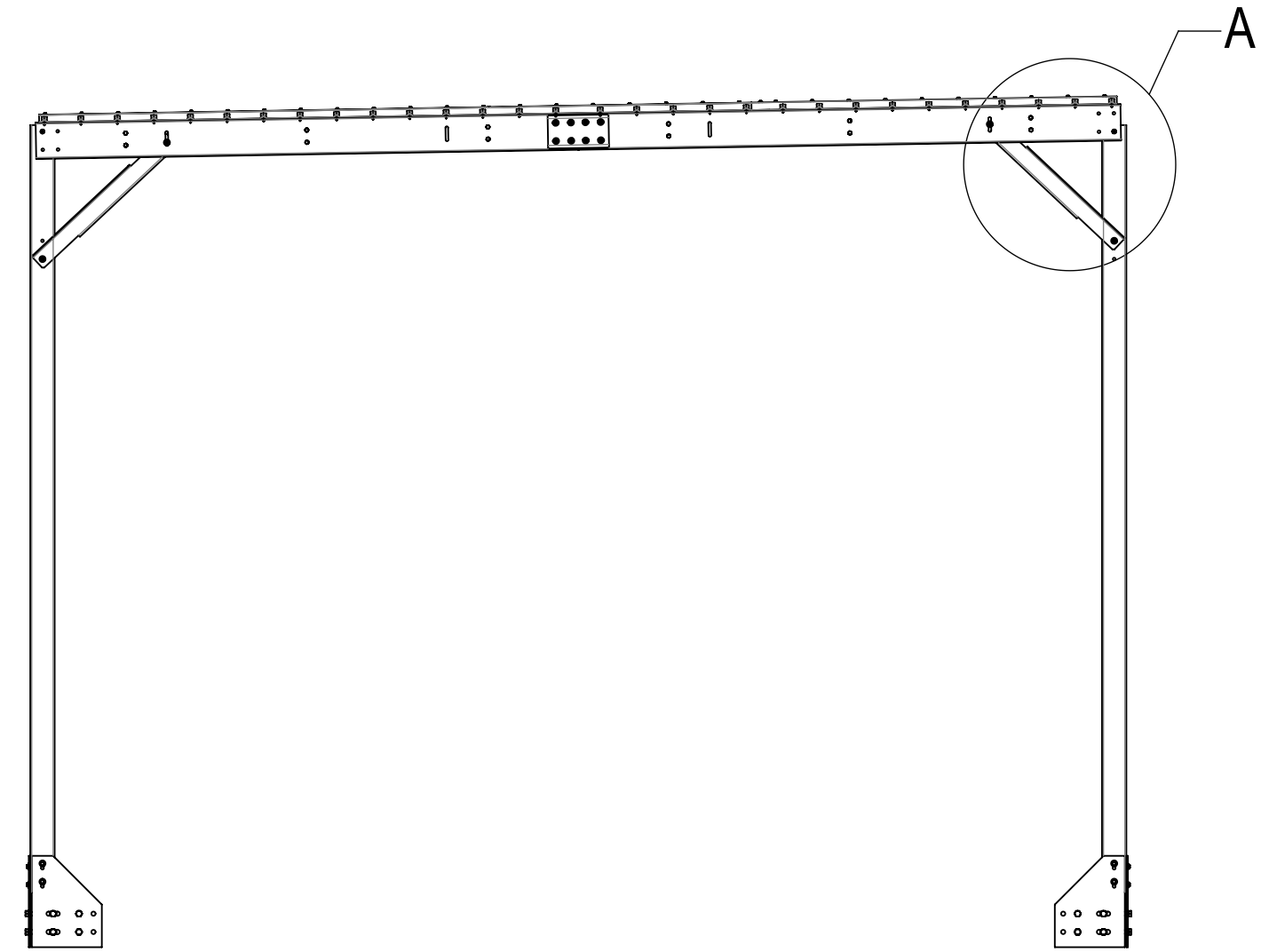

HIDE ROOF DECKING FOR CLARITY

|   |               |                                 |        |          |
|---|---------------|---------------------------------|--------|----------|
| COMMSCOPE, INC. OF NORTH CAROLINA             |               |                                 |        |          |
| TITLE<br>10'X15' RAIN CANOPY, ON EQ. PLATFORM |               |                                 |        |          |
| SIZE<br>C                                     | SCALE<br>1:32 | DOCUMENT NO.<br>EQ-P1015-B-RC-P |        |          |
|   |               | DRAWING                         |        | SHEET    |
|   |               | VERSION                         | STATUS | REVISION |
|   |               | 00                              | RE     | A        |
|   |               |                                 |        | 3 OF 4   |

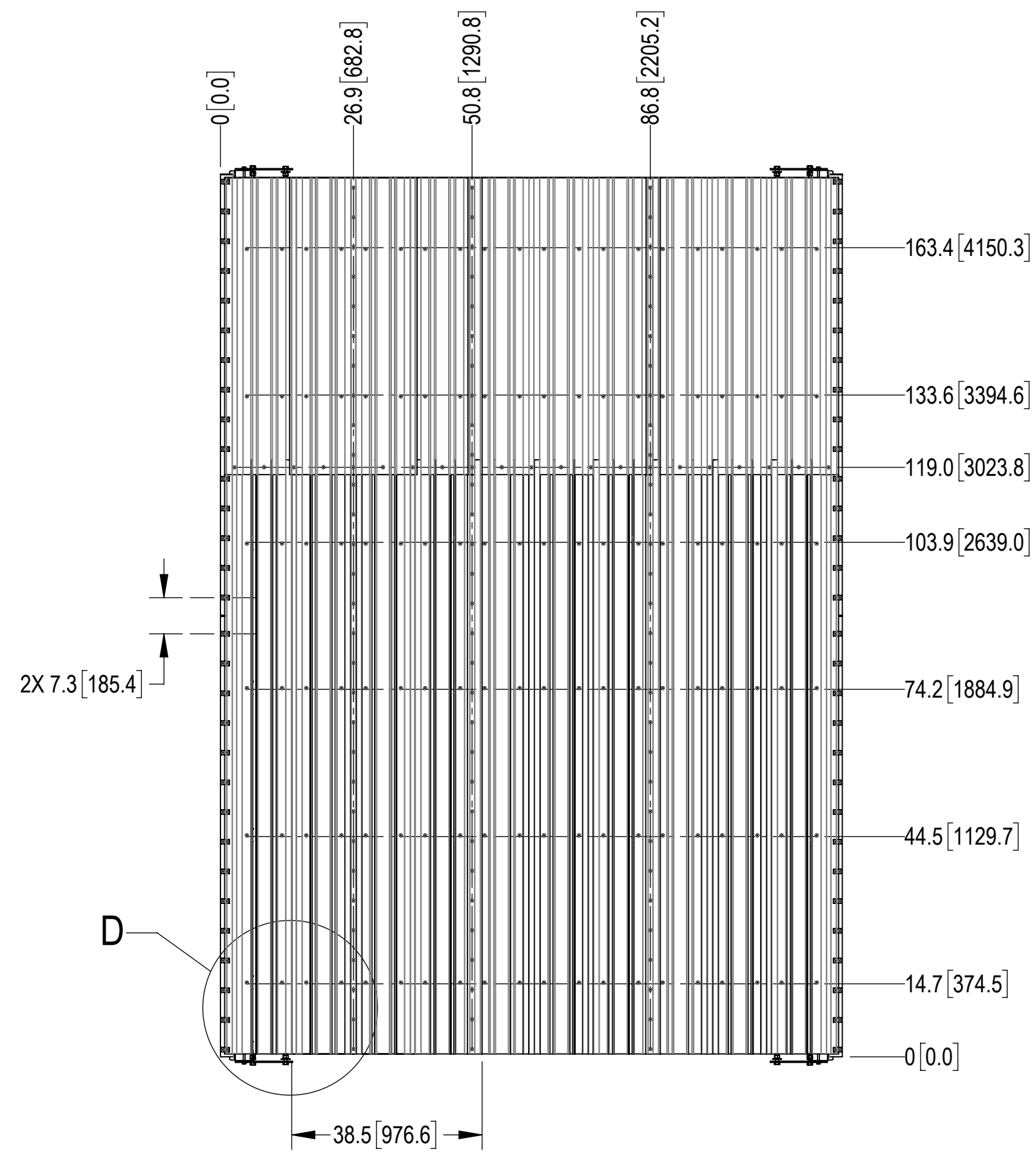

OVERLAP WITH LAST DECK MATERIAL.  
(COULD BE TRIMMED IF NEED)

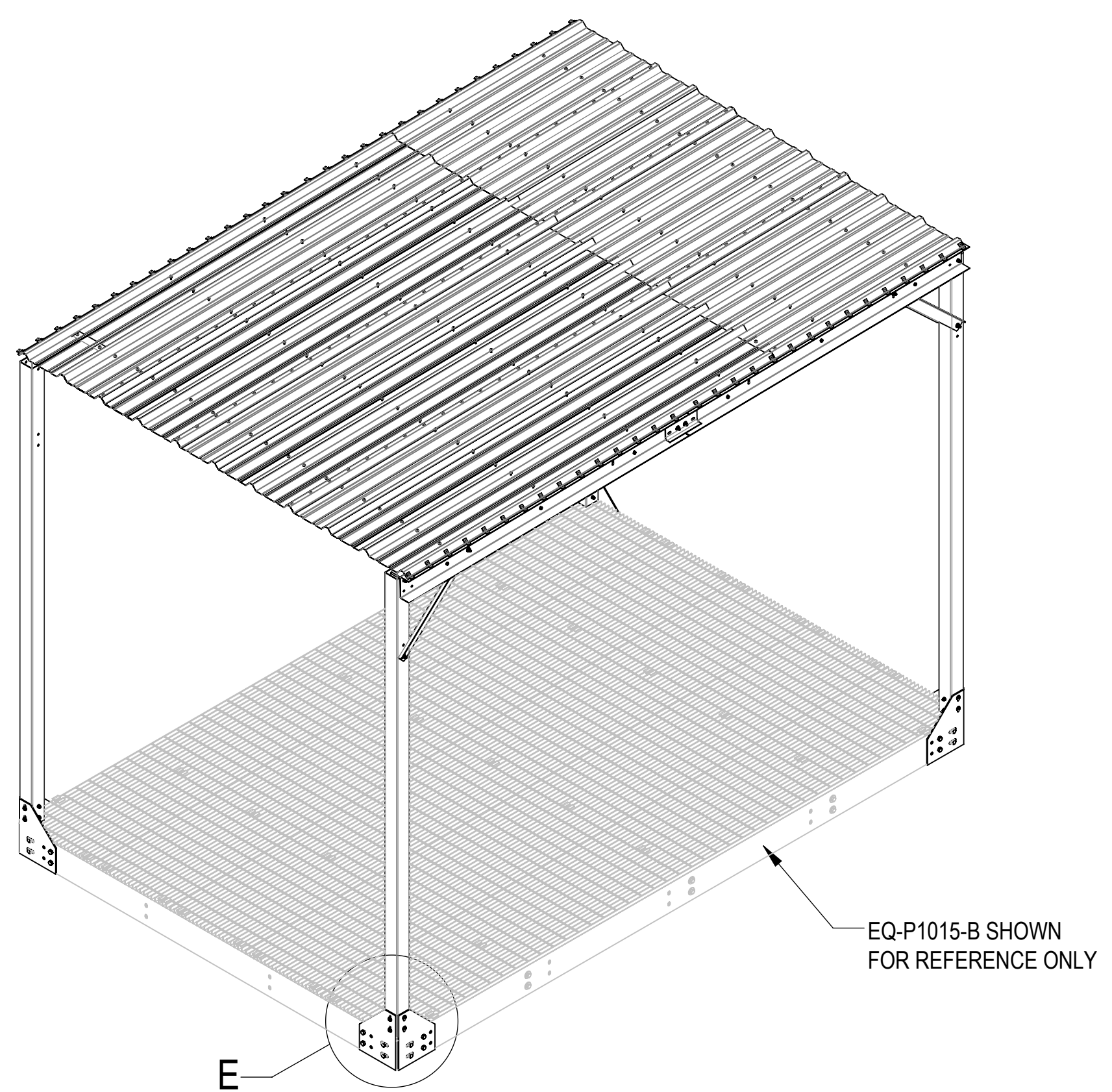

ATTACHED TO EQ-P1015-B VIEW

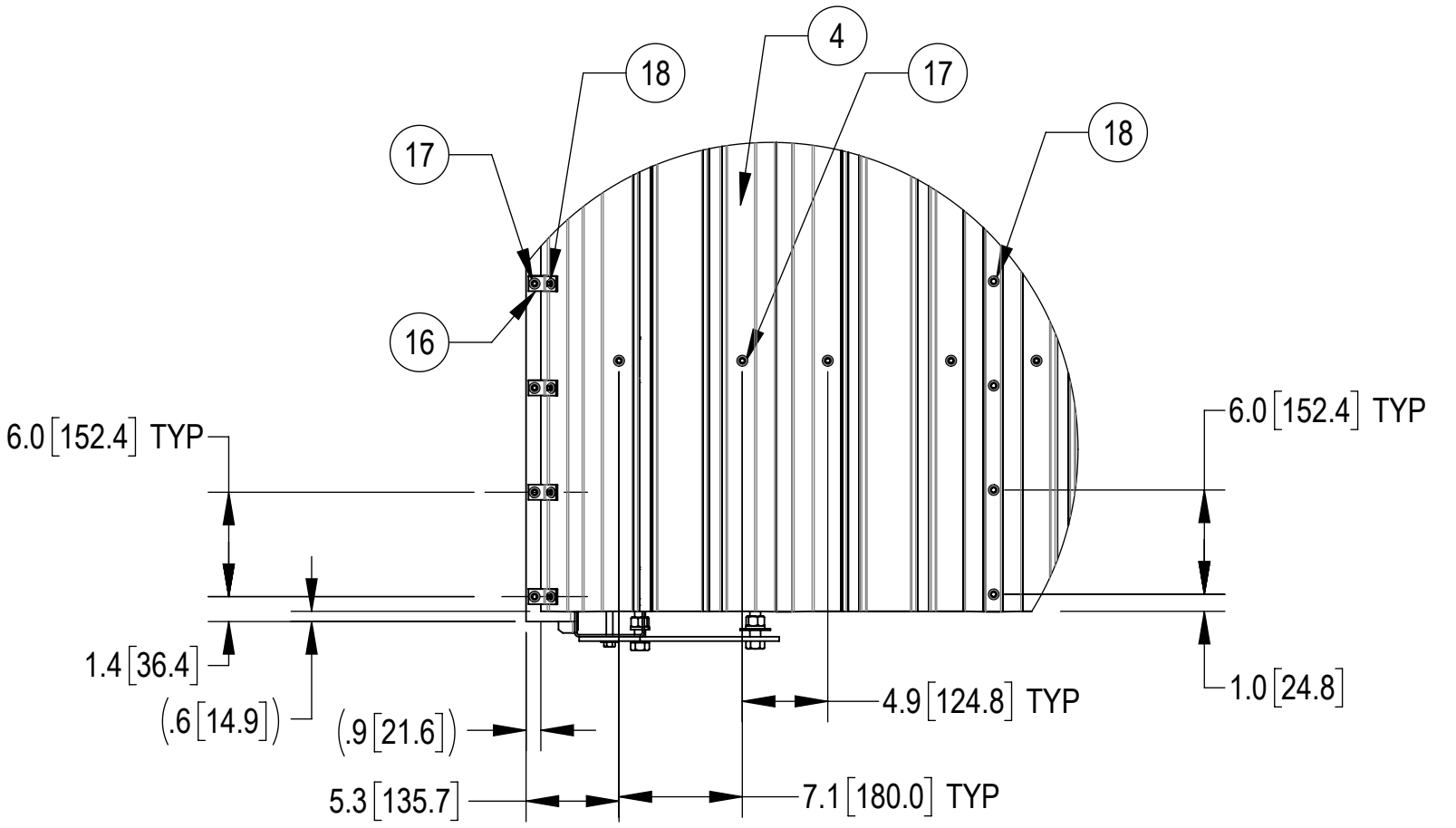

DETAIL D  
SCALE 1 : 10

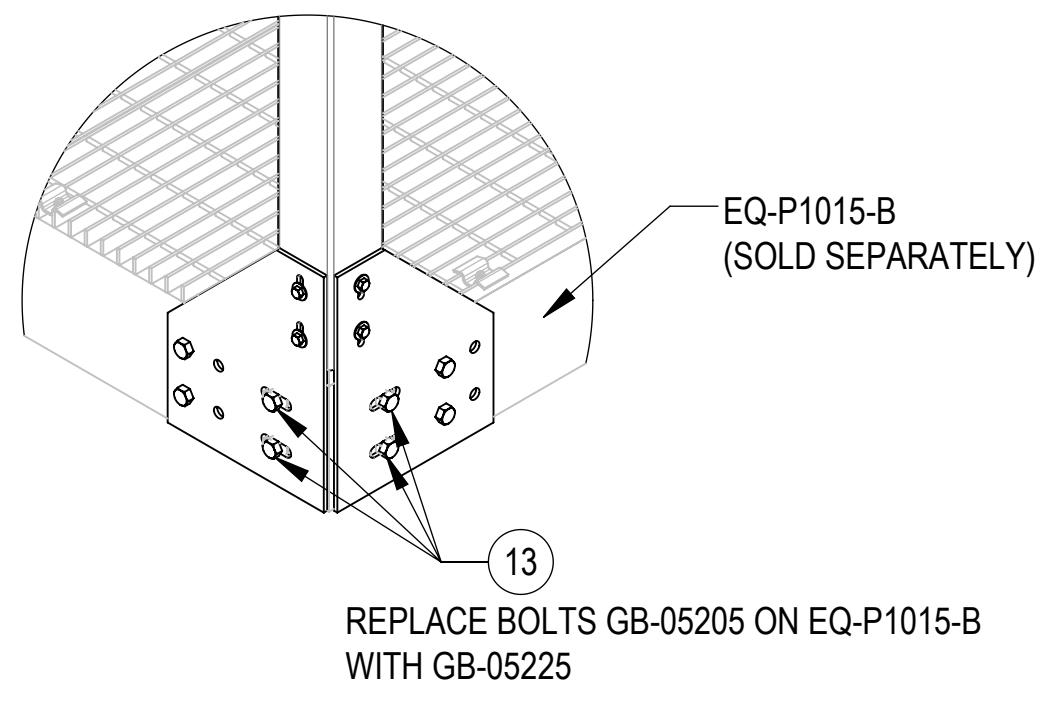

DETAIL E  
SCALE 1 : 10  
(4 PLACES)

|   |               |                                 |        |          |
|---|---------------|---------------------------------|--------|----------|
| COMMSCOPE, INC. OF NORTH CAROLINA             |               |                                 |        |          |
| TITLE<br>10'X15' RAIN CANOPY, ON EQ. PLATFORM |               |                                 |        |          |
| SIZE<br>C                                     | SCALE<br>1:32 | DOCUMENT NO.<br>EQ-P1015-B-RC-P |        |          |
|   |               | DRAWING                         |        | SHEET    |
|   |               | VERSION                         | STATUS | REVISION |
|   |               | 00                              | RE     | A        |
|   |               |                                 |        | 4 OF 4   |