

4-SIDED SUPPORT RAIL CORNER BRACKET
ISOMETRIC VIEW

NOTES:
1. HOT-DIPPED GALVANIZED PER ASTM A123.

TES-SS-PLK4 (SUPPORT RAIL CORNER BRACKET)					
ITEM NO.	QTY.	PART NO.	DESCRIPTION	SHEET #	WT
1	1	CBP4-L	CORNER BENT PLATE BRACKET	PLK3-F1	9
2	1	CBP4-R	CORNER BENT PLATE BRACKET	PLK3-F2	9
3	4	MS02-625-300-500	RU-BOLT 5/8" X 3" I.W. X 5" I.L. A36 (OR EQUIV.)	RBC-1	5
4	8	---	BOLT 5/8" X 2" A325	---	3
5	16	FW-625	5/8" HDG USS FLAT WASHER	---	0
6	16	LW-625	5/8" HDG LOCK WASHER	---	0
7	16	NUT-625	5/8" HDG HEX NUT	---	0
GALVANIZED WT					24.67

DRAWN BY: MN/ CHECKED BY: KW/FL

REV.	DESCRIPTION	BY	DATE
1	FIRST ISSUE	MN/	07/19/23

SHEET TITLE:
TES-SS-PLK4
4-SIDED SUPPORT RAIL
CORNER BRACKET

SHEET NUMBER: TES-SS-PLK4
REV #: 0

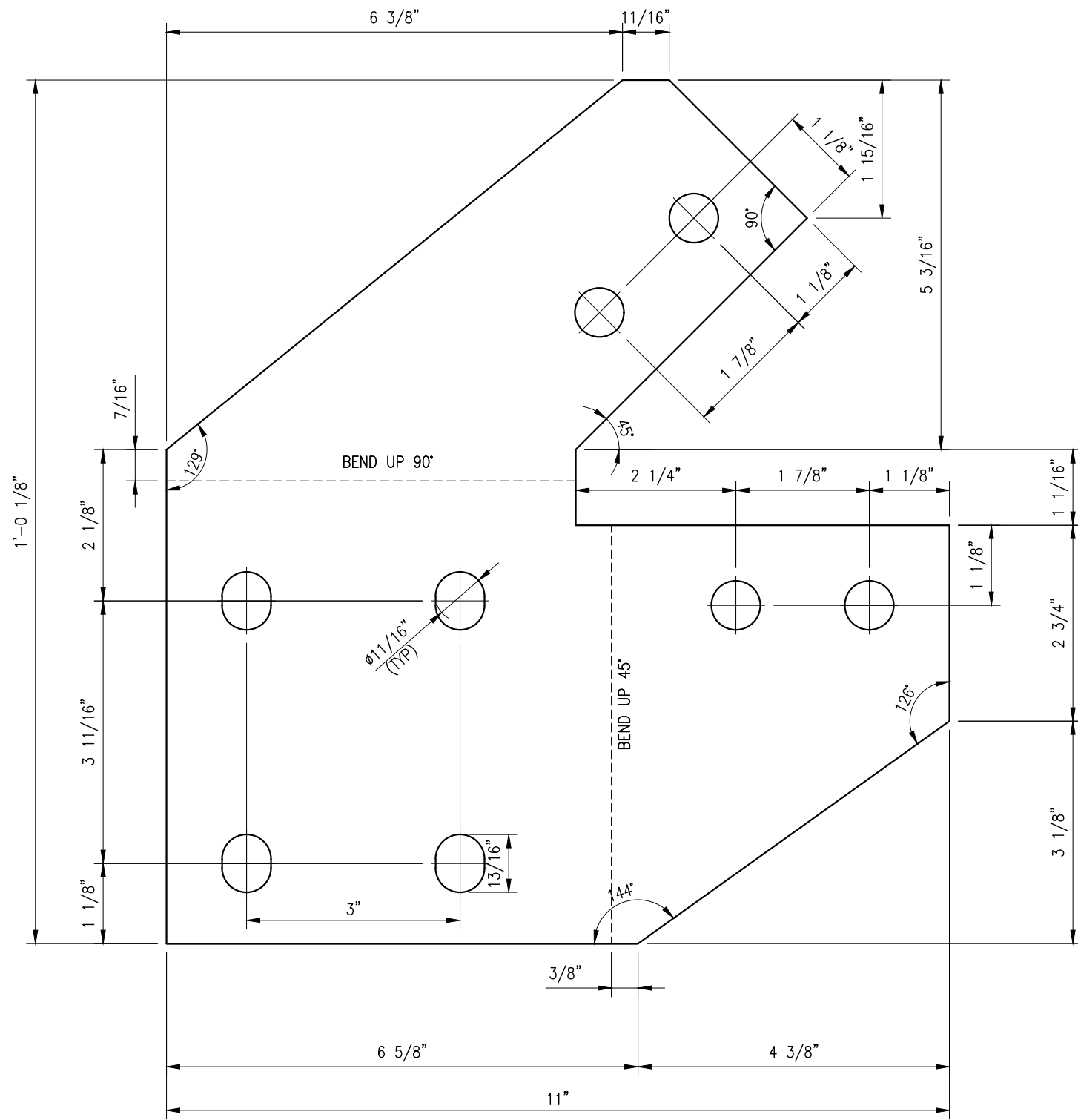

BEFORE BENDING

CBP4-L
 PL 3/8" X 1'-0 1/8" X 11" A36
 (8.93 LBS)

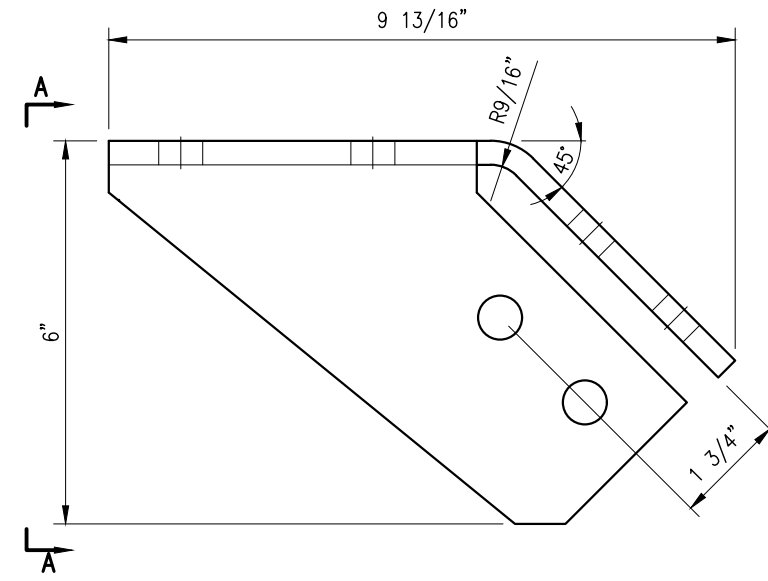

TOP VIEW
 AFTER BENDING

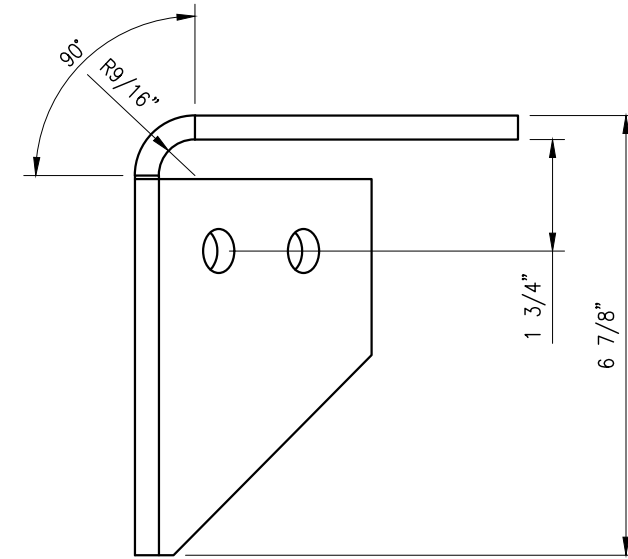

SECTION "A-A"

- NOTES:
1. ALL HOLES ARE 11/16" DIA. U.N.O
 2. HOT-DIPPED GALVANIZED PER ASTM A123.

DRAWN BY: MN/ CHECKED BY: KW/FL

REV.	DESCRIPTION	BY	DATE
1	FIRST ISSUE	MN/	07/19/23

SHEET TITLE:

FABRICATION DETAILS

SHEET NUMBER: REV #:

PLK4-F1 0

STANDARD RU-BOLT CHART							
DESCRIPTION	(EQUIVALENT PART NO.)	"A"	"B"	"C"	"D"	"E"	"WGT"
3/8" RU-BOLT	MS02-375-8125-1625	3/8"	13/16"	15/8"	7/8"	1 3/16"	0.26
3/8" RU-BOLT	MS02-375-100-225	3/8"	1"	2 1/4"	1 1/4"	1 3/8"	0.30
3/8" RU-BOLT	MS02-375-125-225	3/8"	1 1/4"	2 1/4"	1 1/4"	1 5/8"	0.30
3/8" RU-BOLT	MS02-375-1125-18125	3/8"	1 1/8"	1 13/16"	1 1/4"	1 1/2"	0.27
3/8" RU-BOLT	MS02-375-150-250	3/8"	1 1/2"	2 1/2"	1 1/4"	1 7/8"	0.32
3/8" RU-BOLT	MS02-375-150-275	3/8"	1 1/2"	2 3/4"	1 5/8"	1 7/8"	0.34
3/8" RU-BOLT	MS02-375-150-300	3/8"	1 1/2"	3"	1 3/4"	1 7/8"	0.35
3/8" RU-BOLT	MS02-375-175-275	3/8"	1 3/4"	2 3/4"	1 1/8"	2 1/8"	0.34
3/8" RU-BOLT	MS02-375-200-2625	3/8"	2"	2 5/8"	1 1/4"	2 3/8"	0.34
3/8" RU-BOLT	MS02-375-200-125	3/8"	2"	3"	1-1/4"	2-3/8"	0.40
3/8" RU-BOLT	MS02-375-2125-300	3/8"	2 1/8"	3"	1 1/4"	2 1/2"	0.36
3/8" RU-BOLT	MS02-375-250-30625	3/8"	2 1/2"	3 1/16"	1 1/4"	2 7/8"	0.38
3/8" RU-BOLT	MS02-375-250-3125	3/8"	2 1/2"	3 1/8"	1 1/4"	2 7/8"	0.37
3/8" RU-BOLT	MS02-375-250-3625	3/8"	2 1/2"	3-5/8"	1 3/4"	2 7/8"	0.45
3/8" RU-BOLT	MS02-375-300-3625	3/8"	3"	3 5/8"	1 1/4"	3 3/8"	0.42
3/8" RU-BOLT	MS02-375-300-425	3/8"	3"	4 1/4"	2"	3 3/8"	0.50
3/8" RU-BOLT	MS02-375-300-6625	3/8"	3	6 5/8"	3	3 3/8"	0.53
3/8" RU-BOLT	MS02-375-350-4125	3/8"	3 1/2"	4 1/8"	1 1/4"	3 7/8"	0.46
3/8" RU-BOLT	MS02-375-350-475	3/8"	3 1/2"	4 3/4"	2"	3 7/8"	0.50
3/8" RU-BOLT	MS02-375-400-575	3/8"	4"	5 3/4"	2 1/2"	4 3/8"	0.60

1/2" RU-BOLT	MS02-500-75-350	1/2"	3/4"	3 1/2"	2 1/2"	1 1/4"	0.60
1/2" RU-BOLT	MS02-500-1563-350	1/2"	1 9/16"	3 1/2"	2"	2 1/16"	0.62
1/2" RU-BOLT	MS02-500-200-300	1/2"	2"	3"	1 1/4"	2 1/2"	0.55
1/2" RU-BOLT	MS02-500-200-375	1/2"	2"	3 3/4"	1 3/4"	2 1/2"	0.67
1/2" RU-BOLT	MS02-500-20625-500	1/2"	2 1/16"	5	3"	2 9/16"	0.80
1/2" RU-BOLT	MS02-500-225-450	1/2"	2 1/4"	4 1/2"	2 1/2"	2 3/4"	0.76
1/2" RU-BOLT	MS02-500-2438-3625	1/2"	2 7/16"	3 5/8"	1 3/4"	2 15/16"	0.67
1/2" RU-BOLT	MS02-500-2438-5375	1/2"	2 7/16"	5 3/8"	3"	2 15/16"	0.86
1/2" RU-BOLT	MS02-500-250-400	1/2"	2 1/2"	4"	2 1/2"	3"	0.70
1/2" RU-BOLT	MS02-500-250-450	1/2"	2 1/2"	4 1/2"	2 1/2"	3"	0.76
1/2" RU-BOLT	MS02-500-29375-575	1/2"	2 15/16"	5 3/4"	3"	3 7/16"	0.92
1/2" RU-BOLT	MS02-500-300-4125	1/2"	3"	4 1/8"	2"	3 1/2"	0.74
1/2" RU-BOLT	MS02-500-300-450	1/2"	3"	4 1/2"	1 5/8"	3 1/2"	0.73
1/2" RU-BOLT	MS02-500-300-500	1/2"	3"	5"	2 1/2"	3 1/2"	0.84
1/2" RU-BOLT	MS02-500-350-500	1/2"	3 1/2"	5"	1 1/2"	4"	0.78
1/2" RU-BOLT	MS02-500-350-850	1/2"	3 1/2"	8 1/2"	3"	4"	1.09
1/2" RU-BOLT	MS02-500-3625-550	1/2"	3 5/8"	5 1/2"	3"	4 1/8"	1.10
1/2" RU-BOLT	MS02-500-3625-600	1/2"	3 5/8"	6"	2 1/2"	4 1/8"	0.97
1/2" RU-BOLT	MS02-500-3563-450	1/2"	3 9/16"	4 1/2"	2"	4 1/16"	0.80
1/2" RU-BOLT	MS02-500-3563-650	1/2"	3 9/16"	6 1/2"	3"	4 1/16"	1.02
1/2" RU-BOLT	MS02-500-400-550-B	1/2"	4"	5 1/2"	1 1/2"	4 1/2"	0.84
1/2" RU-BOLT	MS02-500-400-550	1/2"	4"	5 1/2"	2"	4 1/2"	0.92
1/2" RU-BOLT	MS02-500-4063-700	1/2"	4 1/16"	7"	3"	4 9/16"	1.09
1/2" RU-BOLT	MS02-500-4125-600	1/2"	4 1/8"	6"	2 1/2"	4 5/8"	0.98
1/2" RU-BOLT	MS02-500-450-600	1/2"	4 1/2"	6"	1 1/2"	5"	0.89
1/2" RU-BOLT	MS02-500-4625-700	1/2"	4 5/8"	7"	2 1/2"	5 1/8"	1.11
1/2" RU-BOLT	MS02-500-4563-750	1/2"	4 9/16"	7 1/2"	3"	5 1/16"	1.16
1/2" RU-BOLT	MS02-500-5625-725	1/2"	5 5/8"	7 1/4"	2"	6 1/8"	1.04
1/2" RU-BOLT	MS02-500-4563-575	1/2"	4 9/16"	5 3/4"	2"	5 1/16"	0.97
1/2" RU-BOLT	MS02-500-5563-700	1/2"	5 9/16"	7"	2"	6 1/16"	1.14
1/2" RU-BOLT	MS02-500-575-750	1/2"	5 3/4"	7 1/2"	2 1/2"	6 1/4"	1.22
1/2" RU-BOLT	MS02-500-6625-800	1/2"	6 5/8"	8"	3"	7 1/8"	1.28
1/2" RU-BOLT	MS02-500-675-850	1/2"	6 3/4"	8 1/2"	2 1/2"	7 1/4"	1.17
1/2" RU-BOLT	MS02-500-675-8375	1/2"	6 3/4"	8 3/8"	2"	7 1/4"	1.24
1/2" RU-BOLT	MS02-500-8750-1025	1/2"	8 3/4"	10 1/4"	3"	9 1/4"	1.60
1/2" RU-BOLT	MS02-500-875-10375	1/2"	8 3/4"	10 3/8"	2"	9 1/4"	1.34
1/2" RU-BOLT	MS02-500-10875-1300	1/2"	10 7/8"	1'-1"	3"	11 3/8"	1.98

NOTES:

IF EQUIVALENT U-BOLTS ARE USED, THE FOLLOWING SPECIFICATIONS ARE REQUIRED:

1. THE MATERIAL SHALL BE HOT ROLLED STEEL WITH A MINIMUM YIELD STRENGTH OF 36 KSI.
2. ALL U-BOLTS SHALL BE HOT DIP GALVANIZED PER ASTM A153-78.
3. TOLERANCE: FOR "C" AND "D" +/- 1/16", "B" AND "E" + 1/16", "A" +/- 1/32".

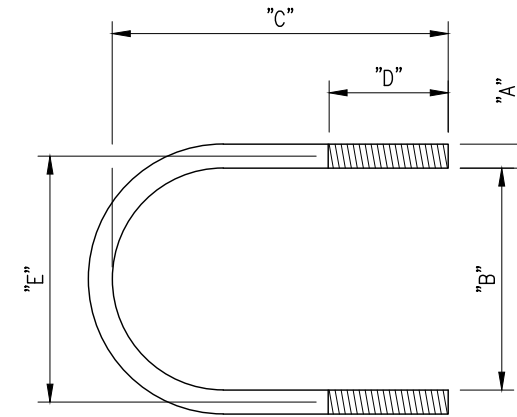

STANDARD RU-BOLT CHART							
DESCRIPTION	(EQUIVALENT PART NO.)	"A"	"B"	"C"	"D"	"E"	"WGT"
5/8" RU-BOLT	MS02-625-200-375	5/8"	2"	3 3/4"	2"	2 5/8"	1.15
5/8" RU-BOLT	MS02-625-2063-500	5/8"	2 1/16"	5"	3"	2 11/16"	1.32
5/8" RU-BOLT	MS02-625-2438-5375	5/8"	2 7/16"	5 3/8"	3"	3 1/16"	1.40
5/8" RU-BOLT	MS02-625-250-400	5/8"	2 1/2"	4"	2 1/2"	3 1/8"	1.17
5/8" RU-BOLT	MS02-625-2625-450	5/8"	2 5/8"	4 1/2"	2"	3 1/4"	1.20
5/8" RU-BOLT	MS02-625-2563-550	5/8"	2 9/16"	5 1/2"	3"	3 3/16"	1.43
5/8" RU-BOLT	MS02-625-2938-5875	5/8"	2 15/16"	5 7/8"	3"	3 9/16"	1.52
5/8" RU-BOLT	MS02-625-300-400	5/8"	3"	4"	2"	3 5/8"	1.20
5/8" RU-BOLT	MS02-625-300-500	5/8"	3"	5"	3"	3 5/8"	1.37
5/8" RU-BOLT	MS02-625-3063-600	5/8"	3 1/16"	6"	3"	3 11/16"	1.54
5/8" RU-BOLT	MS02-625-3625-600	5/8"	3 5/8"	6"	3"	4 1/4"	1.45
5/8" RU-BOLT	MS02-625-3563-650	5/8"	3 9/16"	6 1/2"	3"	4 3/16"	1.65
5/8" RU-BOLT	MS02-625-4063-700	5/8"	4 1/16"	7"	3"	4 11/16"	1.77
5/8" RU-BOLT	MS02-625-4125-600	5/8"	4 1/8"	6"	3"	4 3/4"	1.60
5/8" RU-BOLT	MS02-625-4625-700	5/8"	4 5/8"	7"	3"	5 1/4"	1.60
5/8" RU-BOLT	MS02-625-4563-750	5/8"	4 9/16"	7 1/2"	3"	5 3/16"	1.87
5/8" RU-BOLT	MS02-625-4813-775	5/8"	4 13/16"	7 3/4"	3"	5 7/16"	1.93
5/8" RU-BOLT	MS02-625-500-700	5/8"	5"	7"	3"	5 5/8"	1.96
5/8" RU-BOLT	MS02-625-5063-800	5/8"	5 1/16"	8"	3"	5 11/16"	1.99
5/8" RU-BOLT	MS02-625-5625-85625	5/8"	5 5/8"	8 9/16"	3"	6 1/4"	2.11
5/8" RU-BOLT	MS02-625-575-800	5/8"	5 3/4"	8"	3"	6 3/8"	2.02
5/8" RU-BOLT	MS02-625-6688-9625	5/8"	6 11/16"	9 5/8"	3"	7 5/16"	2.35
5/8" RU-BOLT	MS02-625-6750-900	5/8"	6 3/4"	9"	3"	7 3/8"	2.24
5/8" RU-BOLT	MS02-625-8688-11625	5/8"	8 11/16"	11 5/8"	3"	9 3/16"	2.80
5/8" RU-BOLT	MS02-625-875-1100	5/8"	8 3/4"	11"	3"	9 3/8"	2.70
5/8" RU-BOLT	MS02-625-10688-1375	5/8"	10 13/16"	13 3/4"	3"	11 7/16"	3.27
5/8" RU-BOLT	MS02-625-12875-1575	5/8"	12 7/8"	15 3/4"	3"	13 1/2"	3.72
5/8" RU-BOLT	MS02-625-14125-1700	5/8"	14 1/8"	17"	3"	14 3/4"	4.01

DRAWN BY: MN/ CHECKED BY: KW/FL

REV.	DESCRIPTION	BY	DATE
△	FIRST ISSUE	MN/	07/19/23
△			
△			
△			

SHEET TITLE:

RU-BOLT CHART

SHEET NUMBER: RBC-1 REV #: 0