

- 1.0 GENERAL NOTES
 - 1.1 ALL METRIC DIMENSIONS ARE IN BRACKETS [X.X]
 - 1.2 FOR PATENT INFO: <https://www.cs-pat.com>
- 2.0 DESIGN NOTES
- 3.0 MANUFACTURING/SPECIAL REQUIREMENTS
 - 3.1 TIGHTEN ALL BOLTS SECURING FLAT PLATES BY THE TURN-OF-NUT METHOD. TIGHTEN ALL U-BOLTS USING TURN-OF-NUT METHOD WITH ATTENTION TO LEAVE EQUAL DISTANCE AND EQUAL FORCE ON EACH LEG OF THE U-BOLT.
- 4.0 TEST
- 5.0 PACKAGING
 - 5.1 PACKAGING SHALL MEET COMMScope REQUIREMENTS PER DOCUMENT IS-PL-3005
 - 5.2 PRINTED DOCUMENT TO BE PLACED INSIDE POLYBAG AND THEN IN SHIPPING CONTAINER
 - 5.3 EXTRA HARDWARE MAY BE SUPPLIED BAGGED AND SHIPPED

REVISIONS			
REV.	DESCRIPTION	DATE	APPROVED
A	INITIAL RELEASE	RY1002 01DEC23	YZ1080 40184296CMO

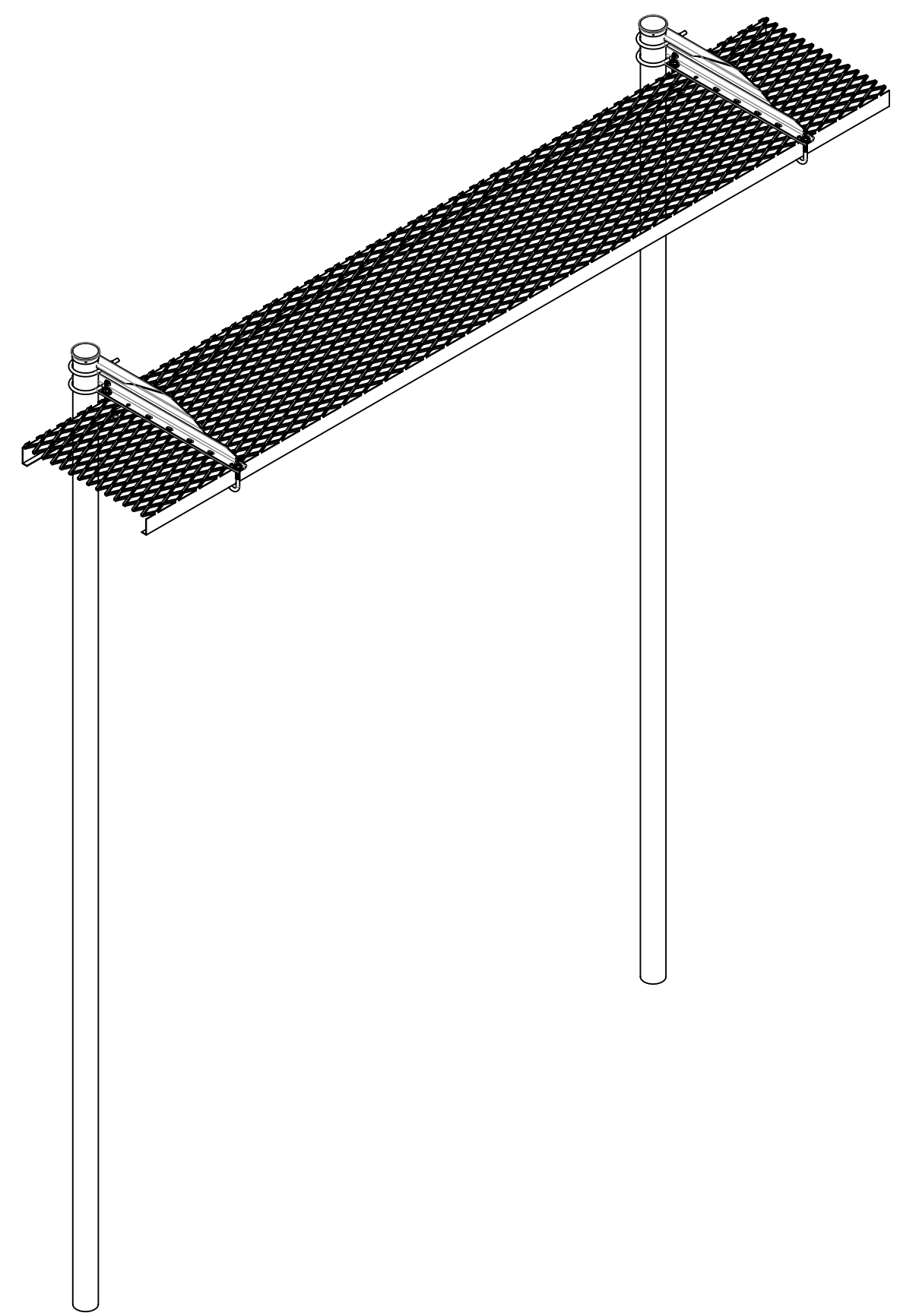
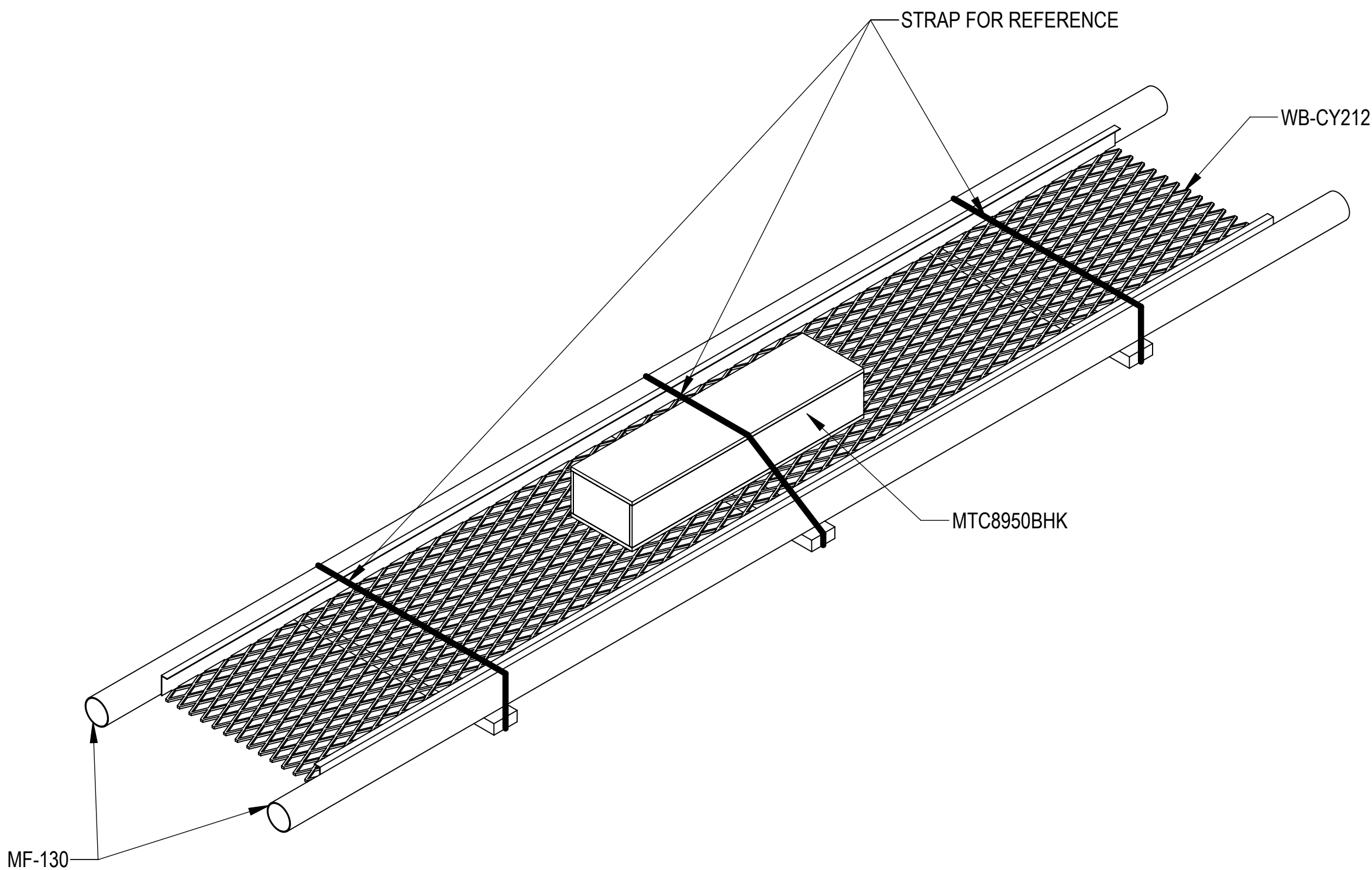

MF-130

STRAP FOR REFERENCE

WB-CY212

MTC8950BHK

COMMScope, INC. OF NORTH CAROLINA									
TOLERANCES					SAP MATERIAL MASTER				
1 PLACE .X[X] ± 0.2[6.3]			3 PLACE .XXX[X] ± 0.060[1.5]			WB-K212-B-NT			
2 PLACE .XX[X] ± 0.12[3.0]			ANGLES ± 2°						
FINISH					MATERIAL				
UNLESS OTHERWISE SPECIFIED DIMENSIONS ARE IN INCHES INTERPRET PER ANSI Y 14.5M-1994		NAME	DATE	TITLE					
	CE	RY1002	01DEC23	ICE-BRIDGE, 24"Wx12'L, BUR-POST, NO-TRAP					
	RW	RY1002	12/21/2023						
	AD	YW1045	01/02/2024						
	RE	YMENG	01/02/2024						
ECN	40184296CMO								
SCALE		DOCUMENT NO.							
1:12		WB-K212-B-NT							
SIZE	Auth Group	INSL	MODEL			DRAWING			
C			VERSION	STATUS	REVISION	VERSION	STATUS	REVISION	SHEET
			00	RE	A	00	RE	A	1 OF 2

DENSITY		lbs/in ³
MASS	233.45	lbs
VOLUME	821.14	in ³
SURFACE AREA	13999.60	in ²
HEIGHT	160.7"	
LENGTH	144.0"	
WIDTH	31.8"	

4

3

2

1

D

D

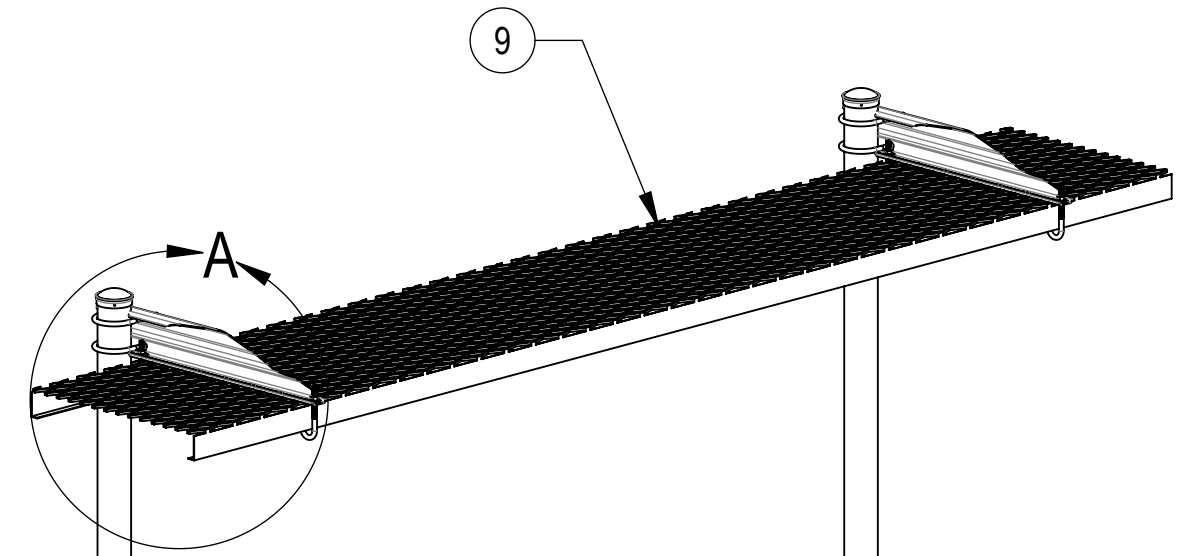
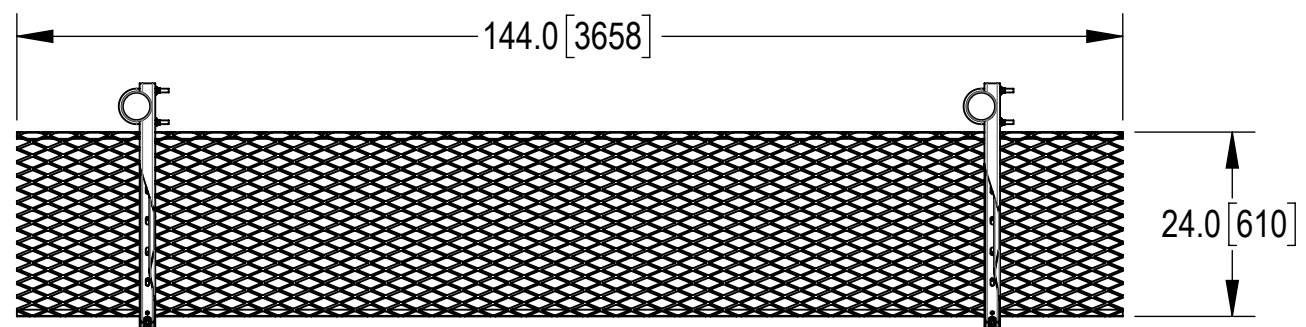

C

C

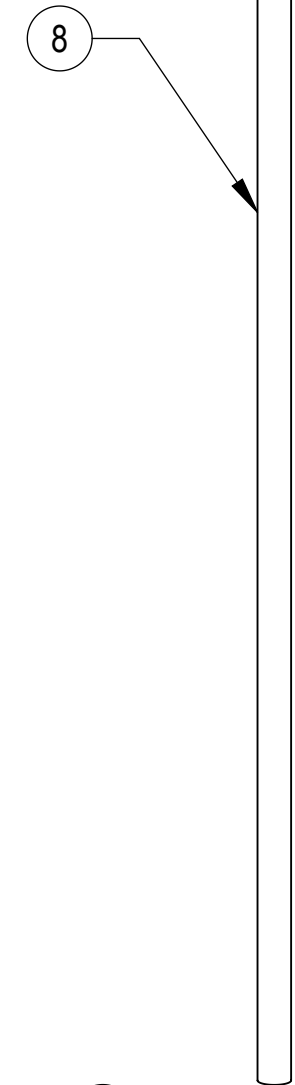
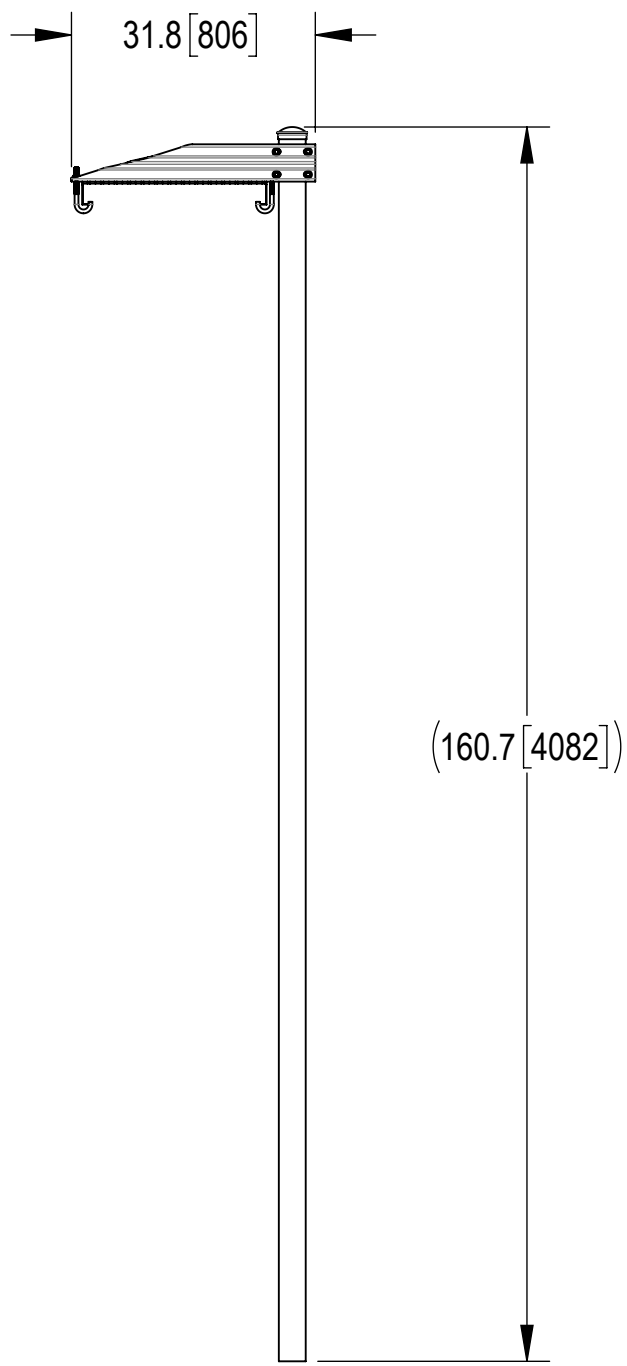
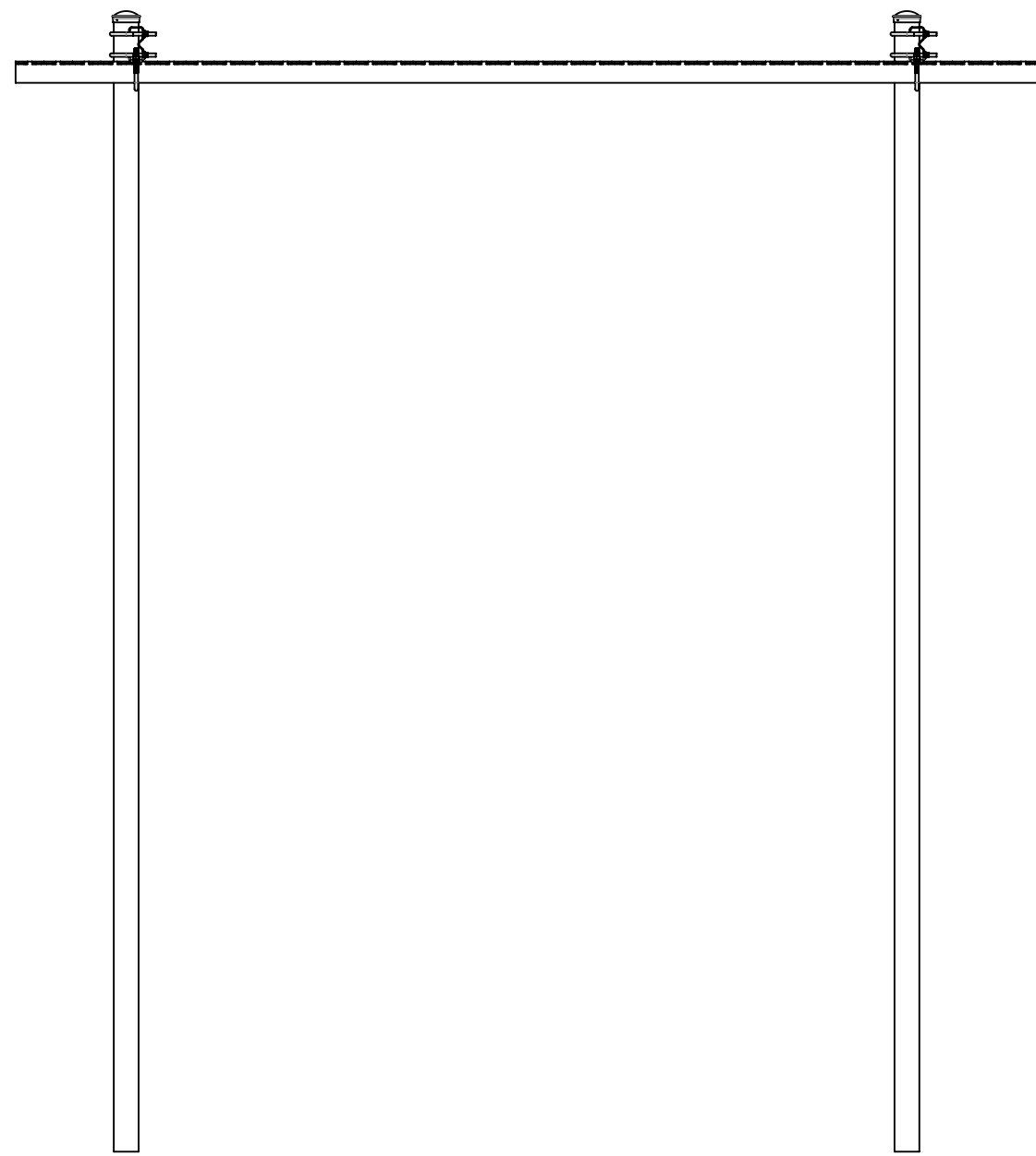

B

B

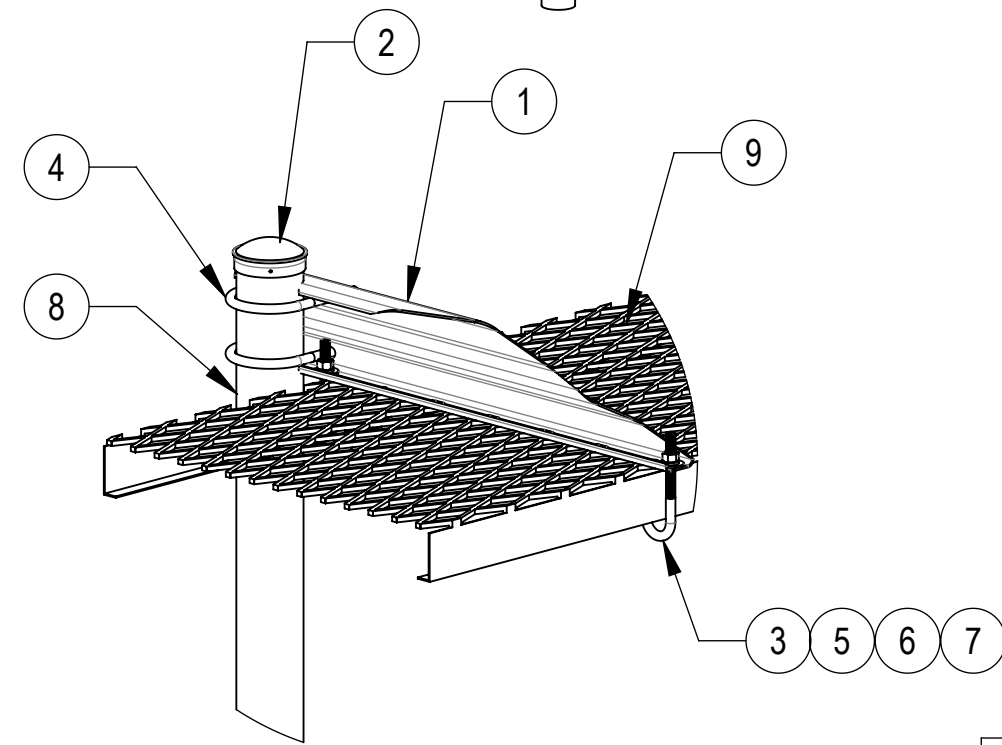

DETAIL A
SCALE 1 : 10

COMPONENT PART NUMBERS PROVIDED FOR ASSEMBLY PURPOSES;
INDIVIDUAL COMPONENTS MAY BE SHIPPED AS PARTS WITHIN AN INCLUDED KIT

ITEM	PART NO.	DESCRIPTION	QTY.	WEIGHT	NOTE NO.
1	WBLB24308	24" WAVEGUIDE BRIDGE SUPPORT BRACKET	2	7.14 LBS	
2	PC-034	PIPE CAP 3-1/2"	2	0.66 LBS	
3	WBJB6	1/2" J-BOLT	4	0.41 LBS	
4	GUB-4356	1/2" X 3-5/8" X 6" GALV U-BOLT	4	0.81 LBS	
5	GWf-04	1/2" GALV FLAT WASHER	4	0.04 LBS	
6	GWL-04	1/2" GALV LOCK WASHER	4	0.01 LBS	
7	GN-04	1/2" GALV HEX NUT	4	0.04 LBS	
8	MF-130	3.5" O.D. X 13'-4" DIRECT BURIAL PIPE COLUMN	2	57.97 LBS	
9	WB-CY212	SAFETY GRATING, 24"X144"	1	96.36 LBS	

COMMSCOPE, INC. OF NORTH CAROLINA				
TITLE ICE-BRIDGE, 24"Wx12'L, BUR-POST, NO-TRAP				
SIZE C	SCALE 1:25	DOCUMENT NO. WB-K212-B-NT		
		DRAWING		SHEET 2 OF 2
		VERSION 00	STATUS RE	

© 2023 CommScope, Inc. Confidential

4

3

2

1

A

A