

- 1.0 GENERAL NOTES  
 1.1 ALL IMPERIAL DIMENSIONS ARE IN BRACKETS [X.XX]  
 1.2 MARK PART WITH IDENTIFICATION NUMBER
- 2.0 DESIGN NOTES  
 2.1 DESIGNED PER CUSTOMER REQUIREMENTS
- 3.0 MANUFACTURING/SPECIAL REQUIREMENTS  
 3.1 TIGHTEN ALL BOLTS SECURING FLAT PLATES BY THE TURN-OF-NUT METHOD. TIGHTEN ALL U-BOLTS USING TURN-OF-NUT METHOD WITH ATTENTION TO LEAVE EQUAL DISTANCE AND EQUAL FORCE ON EACH LEG OF THE U-BOLT.  
 3.2 TOP CONNECTION FITS ON SUPPORT RAIL UP TO 114[4.5] O.D. PIPE.
- 4.0 TEST
- 5.0 PACKAGING  
 5.1 PACKAGING SHALL MEET COMMSCOPE REQUIREMENTS PER DOCUMENT IS-PL-3005  
 5.2 PRINTED DOCUMENT TO BE PLACED INSIDE POLYBAG AND THEN IN SHIPPING CONTAINER  
 5.3 EXTRA HARDWARE MAYBE SUPPLIED, BAGGED AND SHIPPED

REVISIONS			
REV.	DESCRIPTION	DATE	APPROVED
A	INITIAL RELEASE	JL1183 01SEP22	VICENTE 40155958CMO

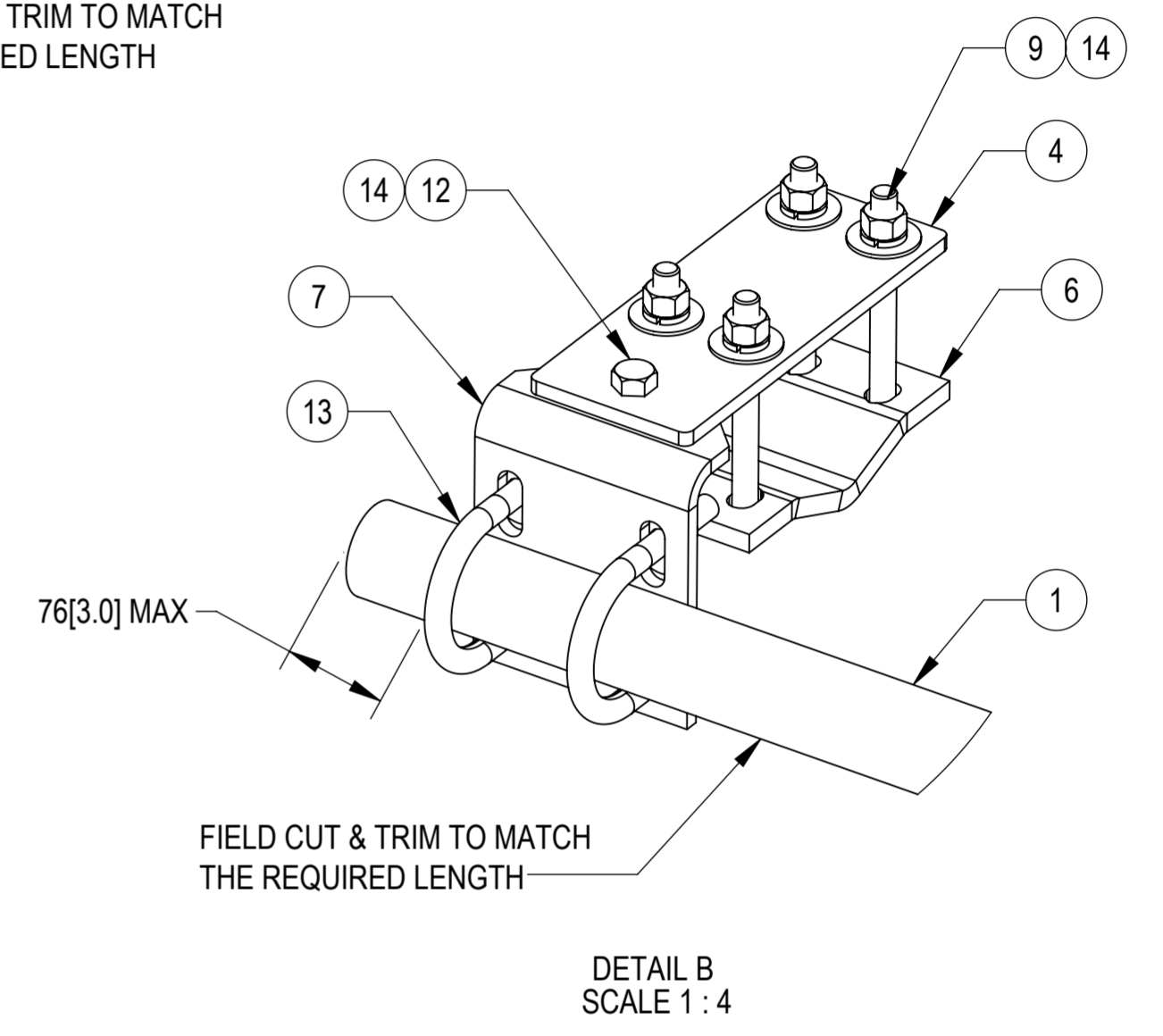
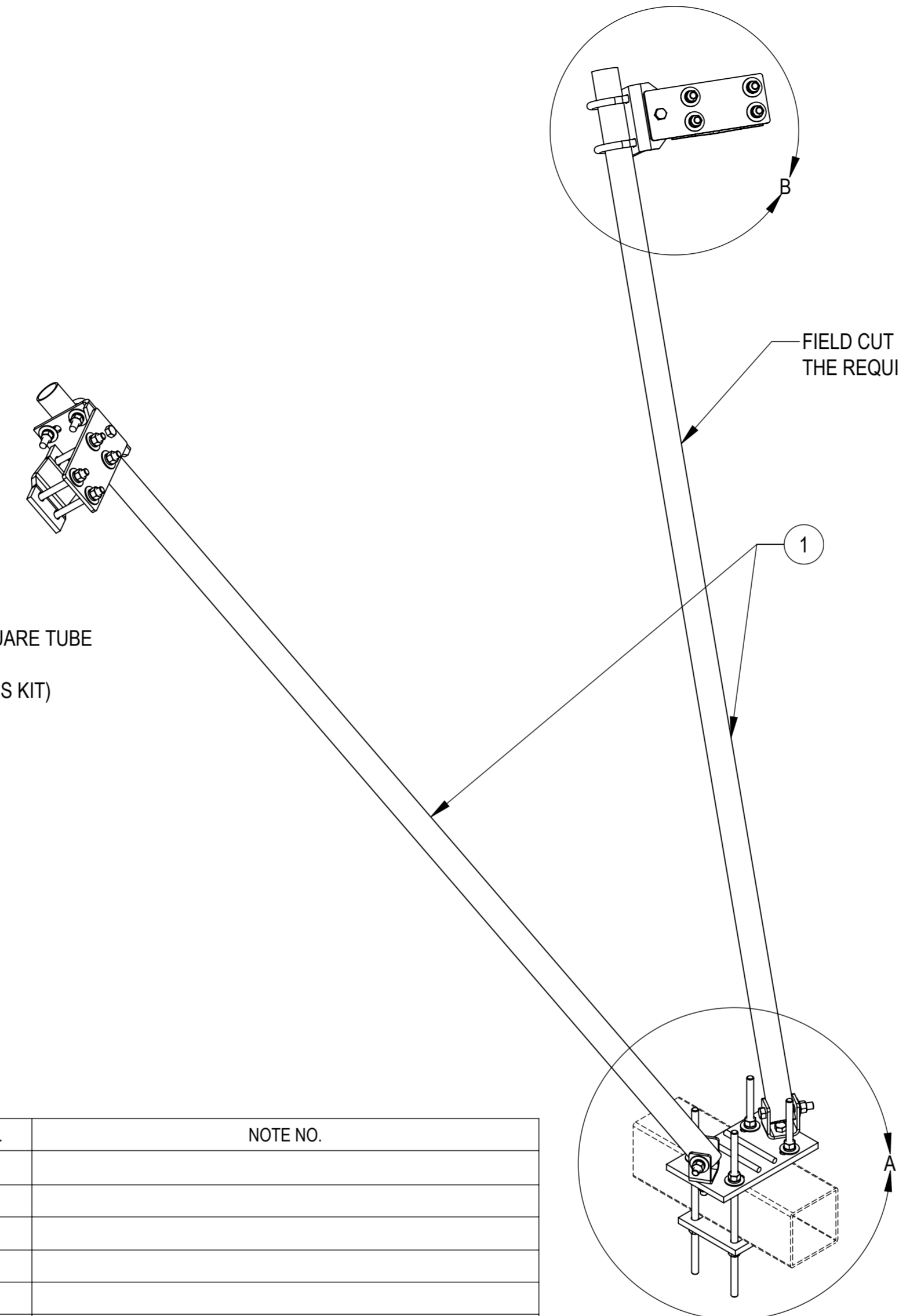
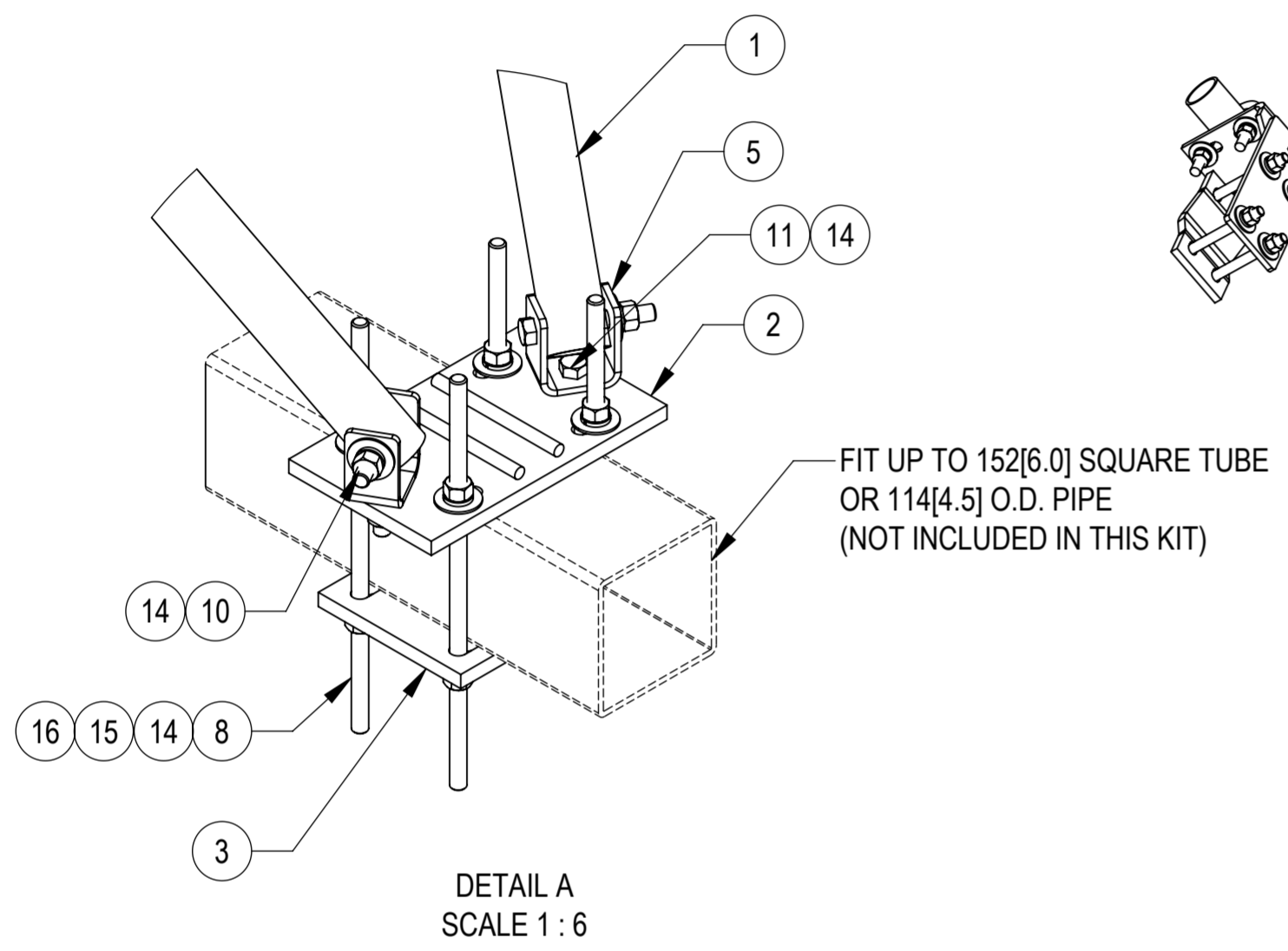

COMPONENT PART NUMBERS PROVIDED FOR ASSEMBLY PURPOSES;  
 INDIVIDUAL COMPONENTS MAY BE SHIPPED AS PARTS WITHIN AN INCLUDED KIT.

ITEM NO.	PART NO.	DESCRIPTION	QTY.	NOTE NO.
1	P40-238X096	PIPE 2 SCH40 (2.375" OD x0.154" THK)	2	
2	PL625-72512	WELDMENT, TOP MOUNTING PLATE	1	
3	PLK8-F2-3	WELDMENT, BOTTOM MOUNTING PLATE	1	
4	PL375-4511	PLATE, TIE BACK MOUNTING	2	
5	MTC4104-0031	BENT PLATE	2	
6	V-CLAMP	CLAMP, 4 SLOT V	2	
7	MTC4104-0014	BENT PLATE, .375 X 6 X 6.88	2	
8	MT-382-18	5/8" X 18" GALV THREADED ROD	4	
9	GB-05605FT	5/8" X 6" GALV BOLT KIT FULL THREAD	8	INCLUDED BOLT, LOCK WASHER AND NUT
10	GB-0544A	5/8" X 4-1/2" GALV BOLT KIT	2	INCLUDED BOLT, LOCK WASHER AND NUT
11	GB-0522A	5/8" X 2-1/4" GALV BOLT KIT (A325)	2	INCLUDED BOLT, LOCK WASHER AND NUT
12	GB-0520A	5/8" X 2" GALV BOLT KIT (A325)	2	INCLUDED BOLT, LOCK WASHER AND NUT
13	GUB-53050	5/8" X 3" X 5" GALV U-BOLT KIT	4	INCLUDES U-BOLT, FLAT WASHERS, LOCK WASHERS AND NUTS
14	GWF-05	5/8" GALV FLAT WASHER, 1.7OD	22	
15	GWL-05	5/8" GALV LOCK WASHER	8	
16	GN-05	5/8" GALV HEX NUT	8	

**COMMSCOPE, INC. OF NORTH CAROLINA**

TOLERANCES		SAP MATERIAL MASTER	
0 PLACE .X[X] ± 6[0.25]	2 PLACE .XX[.XXX] ± 1.50[0.06]	<b>VZWSMART-PLK10</b>	
1 PLACE .X[.XX] ± 3.0[0.12]	ANGLES ± 2°		
FINISH GALV A123		MATERIAL	
<small>UNLESS OTHERWISE SPECIFIED DIMENSIONS ARE IN MILLIMETERS INTERPRET PER ANSI Y 14.5M-1994</small>		NAME	DATE
		CE JL1183	01SEP22
		RW JL1183	09/20/2022
		AD YMENG	09/20/2022
RE JL1183	09/20/2022	<b>SUPPORT RAIL BRACING KIT</b>	
ECN 40155958CMO			
SCALE	DOCUMENT NO.	<b>VZWSMART-PLK10</b>	
1:10			
SIZE	Auth Group	INSL	MODEL
<b>A2</b>		VERSION	STATUS
		00	RE
REVISION		VERSION	STATUS
A		00	RE
DRAWING		REVISION	SHEET
A		A	1 OF 1