

- 1.0 GENERAL NOTES  
 1.1 ALL IMPERIAL DIMENSIONS ARE IN BRACKETS [X.XX]  
 1.2 MARK PART WITH IDENTIFICATION NUMBER
- 2.0 DESIGN NOTES
- 3.0 MANUFACTURING/SPECIAL REQUIREMENTS  
 3.1 TIGHTEN ALL BOLTS SECURING FLAT PLATES BY THE TURN-OF-NUT METHOD. TIGHTEN ALL U-BOLTS USING TURN-OF-NUT METHOD WITH ATTENTION TO LEAVE EQUAL DISTANCE AND EQUAL FORCE ON EACH LEG OF THE U-BOLT.
- 4.0 TEST
- 5.0 PACKAGING  
 5.1 PACKAGING SHALL MEET COMMSCOPE REQUIREMENTS PER DOCUMENT IS-PL-3005  
 5.2 PRINTED DOCUMENT TO BE PLACED INSIDE POLYBAG AND THEN IN SHIPPING CONTAINER  
 5.3 EXTRA HARDWARE MAYBE SUPPLIED, BAGGED AND SHIPPED

REVISIONS			
REV.	DESCRIPTION	DATE	APPROVED
A	INITIAL RELEASE	JL1183 16MAR23	JAHAINES 40168212CMO

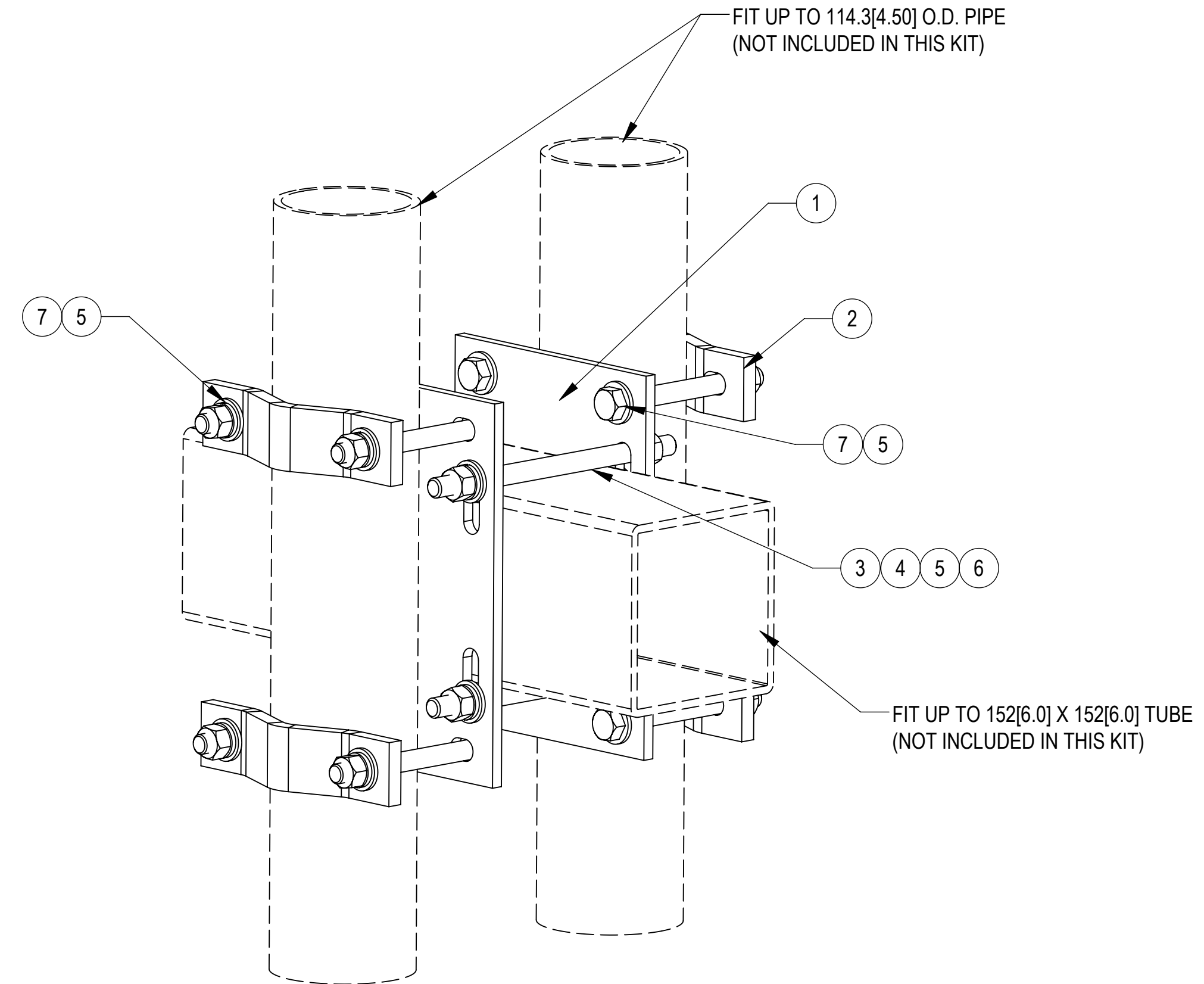

COMPONENT PART NUMBERS PROVIDED FOR ASSEMBLY PURPOSES;  
 INDIVIDUAL COMPONENTS MAY BE SHIPPED AS PARTS WITHIN AN INCLUDED KIT.

ITEM	PART NO.	DESCRIPTION	QTY.	NOTE NO.
1	PL375-8512	PLATE, CROSSOVER MOUNTING	2	
2	VCP	CLAMP, MOUNTING	4	
3	MT-381-10	5/8" X 10" GALV THREADED ROD	4	
4	GN-05	5/8" GALV HEX NUT	8	
5	GWF05A	GALV FLAT WASHER HARDENED 5/8", 1.3OD	24	
6	GWL-05	5/8" GALV LOCK WASHER	8	
7	GB-05605FT	5/8" X 6" GALV BOLT KIT FULL THREAD	8	

DENSITY	40.16	lbs/in <sup>3</sup>
MASS	40.16	lbs
VOLUME	141.88	in <sup>3</sup>
SURFACE AREA	970.36	in <sup>2</sup>
DENSITY	18253.94	g/mm <sup>3</sup>
MASS	18253.94	grams
VOLUME	2325063.20	mm <sup>3</sup>
SURFACE AREA	626040.67	mm <sup>2</sup>
HEIGHT	450[17.7]	
LENGTH	305[12.0]	
WIDTH	216[8.5]	

**COMMSCOPE, INC. OF NORTH CAROLINA**

TOLERANCES		SAP MATERIAL MASTER	
0 PLACE X[.X] ± 5[0.2]	2 PLACE .XX[.XXX] ± 1.50[0.060]	<b>MUK-MSK6</b>	
1 PLACE .X[.XX] ± 3.0[0.12]	ANGLES ± 2°		
FINISH		MATERIAL	
UNLESS OTHERWISE SPECIFIED DIMENSIONS ARE IN MILLIMETERS INTERPRET PER ANSI Y 14.5M-1984		NAME	DATE
		CE JL1183	16MAR23
		RW JL1183	03/21/2023
		AD YW1045	03/23/2023
		RE YMENG	03/24/2023
TITLE		<b>BACK TO BACK CROSSOVER</b>	
ECN 40168212CMO		SCALE	DOCUMENT NO.
		<b>1:8</b>	<b>MUK-MSK6</b>
SIZE	Auth Group	INSL	MODEL
<b>A2</b>			
VERSION	STATUS	REVISION	DRAWING
03	RE	D	VERSION STATUS REVISION
			00 RE A
			SHEET
			1 OF 1