

# RT-ST

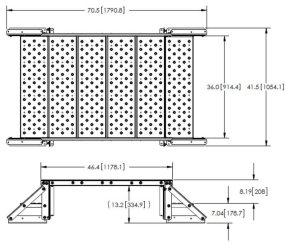

## Rooftop Cable Tray Step Over

### Product Classification

**Product Type** Step over

### General Specifications

**Cable Runs, quantity** 0

**Mounting** Non-penetrating

### Dimensions

**Height** 335.28 mm | 13.2 in

**Width** 1,054.1 mm | 41.5 in

**Length** 1,790.7 mm | 70.5 in

### Outline Drawing

# RT-ST

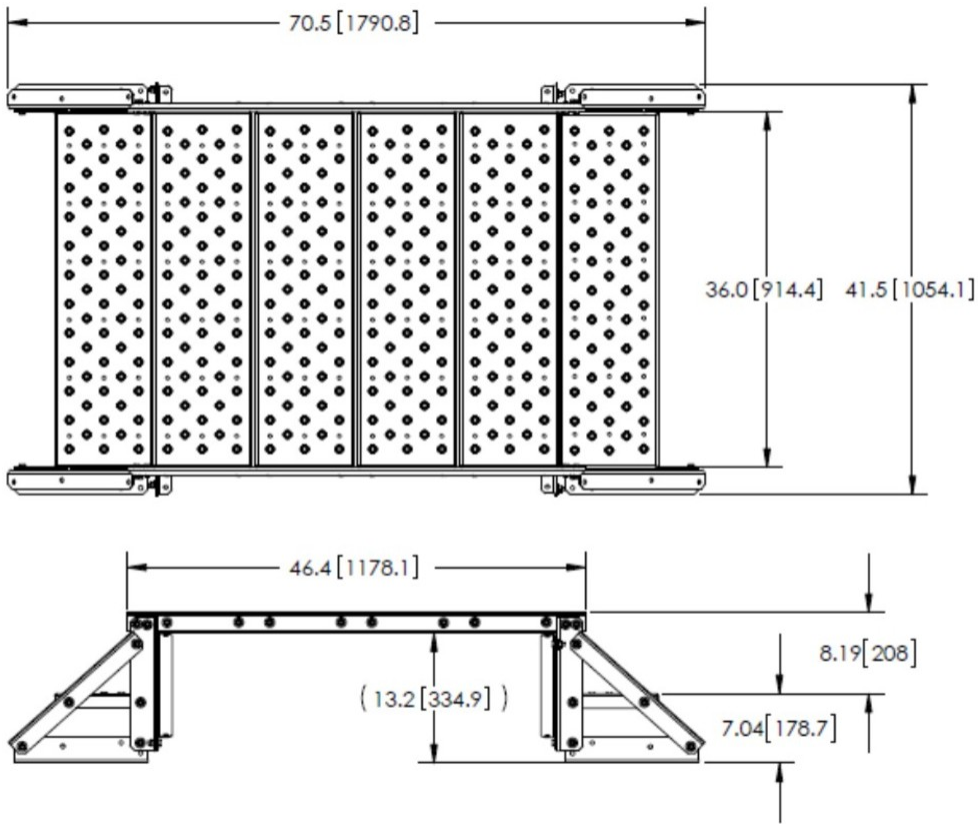

## Material Specifications

**Material Type** Hot dip galvanized steel

## Mechanical Specifications

**Wind Rating** For Specifications, please contact your local ANDREW representative

## Packaging and Weights

**Included** Hardware | Step over

**Packaging quantity** 1

**Weight, net** 66.4 kg | 146.387 lb

## Regulatory Compliance/Certifications

### Agency

CHINA-ROHS

ISO 9001:2015

### Classification

Above maximum concentration value

Designed, manufactured and/or distributed under this quality management system

# RT-ST

---

ROHS Compliant/Exempted

UK-ROHS Compliant/Exempted



## \* Footnotes

### **Wind Rating**

BWS—Base Wind Speed; FBC—Florida Building Code