

7-16 DIN Female for 3/8 in FSJ2 and PTS2 cable



Product Classification

Product Type	Wireless and radiating connector
Product Brand	HELIAX®
Product Series	FSJ2-50

General Specifications

Body Style	Straight
Cable Family	FSJ2-50
Inner Contact Attachment Method	Captivated
Inner Contact Plating	Silver
Interface	7-16 DIN Female
Mounting Angle	Straight
Outer Contact Attachment Method	Compression
Outer Contact Plating	Silver
Pressurizable	No

Dimensions

Height	28.96 mm 1.14 in
Width	28.96 mm 1.14 in
Length	51.56 mm 2.03 in
Diameter	28.96 mm 1.14 in
Nominal Size	3/8 in

Outline Drawing

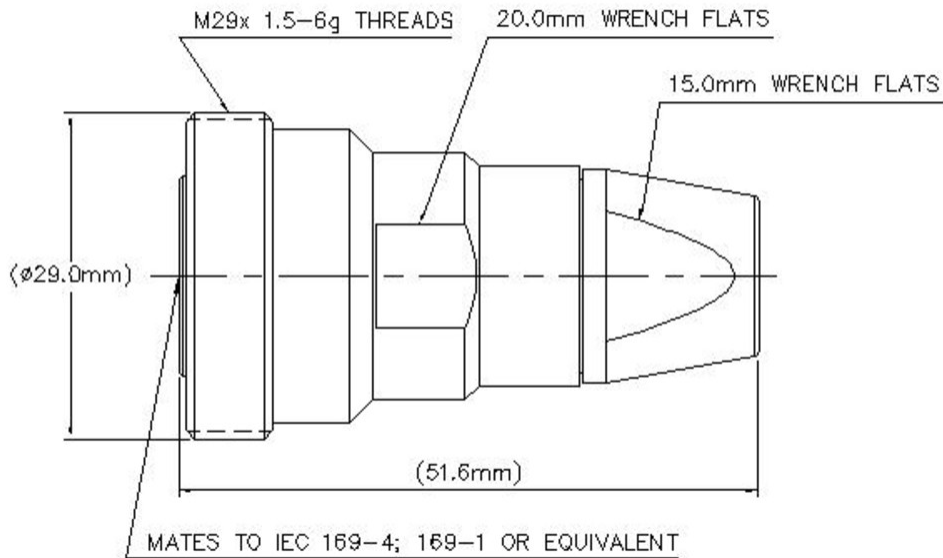

Electrical Specifications

3rd Order IMD at Frequency	-112 dBm @ 910 MHz
3rd Order IMD Test Method	Two +43 dBm carriers
Average Power at Frequency	0.7 kW @ 900 MHz
Cable Impedance	50 ohm
Connector Impedance	50 ohm
dc Test Voltage	2300 V
Inner Contact Resistance, maximum	0.4 mOhm
Insulation Resistance, minimum	10000 MOhm
Operating Frequency Band	0 – 6000 MHz
Outer Contact Resistance, maximum	1.5 mOhm
Peak Power, maximum	13.2 kW
RF Operating Voltage, maximum (vrms)	813 V
Shielding Effectiveness	-110 dB

VSWR/Return Loss

Frequency Band	VSWR	Return Loss (dB)
0-2000 MHz	1.07	30

Mechanical Specifications

F2PDF-C

Connector Retention Tensile Force	671.68 N 151 lbf
Connector Retention Torque	2.7 N-m 23.897 in lb
Coupling Nut Proof Torque	35 N-m 309.776 in lb
Coupling Nut Proof Torque Method	IEC 61169-16:9.3.11
Coupling Nut Retention Force	1000 N 224.81 lbf
Coupling Nut Retention Force Method	IEC 61169-17:9.3.11
Insertion Force	889.64 N 200 lbf
Insertion Force Method	IEC 61169-16:9.3.5
Interface Durability	500 cycles
Interface Durability Method	IEC 61169-4:17
Mechanical Shock Test Method	IEC 60068-2-27

Environmental Specifications

Operating Temperature	-55 °C to +85 °C (-67 °F to +185 °F)
Storage Temperature	-65 °C to +125 °C (-85 °F to +257 °F)
Attenuation, Ambient Temperature	20 °C 68 °F
Average Power, Ambient Temperature	40 °C 104 °F
Average Power, Inner Conductor Temperature	100 °C 212 °F
Corrosion Test Method	IEC 60068-2-11
Immersion Depth	1 m
Immersion Test Mating	Mated
Immersion Test Method	IEC 60529:2001, IP68
Moisture Resistance Test Method	IEC 60068-2-3
Thermal Shock Test Method	IEC 60068-2-14
Vibration Test Method	IEC 60068-2-6

Packaging and Weights

Weight, net	107.47 g 0.237 lb
--------------------	---------------------

Regulatory Compliance/Certifications

Agency	Classification
CHINA-ROHS	Below maximum concentration value
ISO 9001:2015	Designed, manufactured and/or distributed under this quality management system

F2PDF-C

REACH-SVHC

Compliant as per SVHC revision on www.commscope.com/ProductCompliance

ROHS

Compliant



* Footnotes

Immersion Depth

Immersion at specified depth for 24 hours