

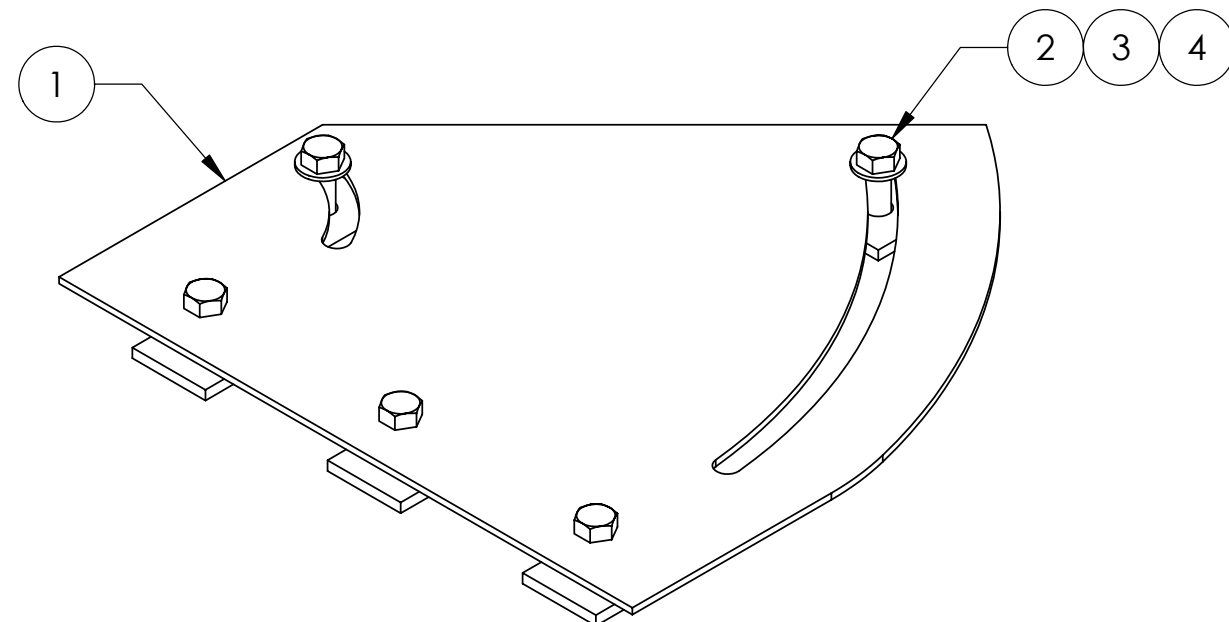

ITEM	PART NO.	DESCRIPTION	QTY.	WEIGHT
1	MTF504.01	ADJUSTABLE SPLICE	1	3.43 LBS
2	GB-03145	3/8" X 1-1/2" GALV BOLT KIT	5	0.11 LBS
3	MT-387	SQUARE WASHER, 1 1/2" X 1 1/2" W/ 7/16" HOLE	5	0.11 LBS
4	GWF-03	3/8" GALV FLAT WASHER	2	0.01 LBS

REVISIONS				
REV.	ZONE	DESCRIPTION	BY	DATE
A		INITIAL RELEASE	DMW	05/07/01

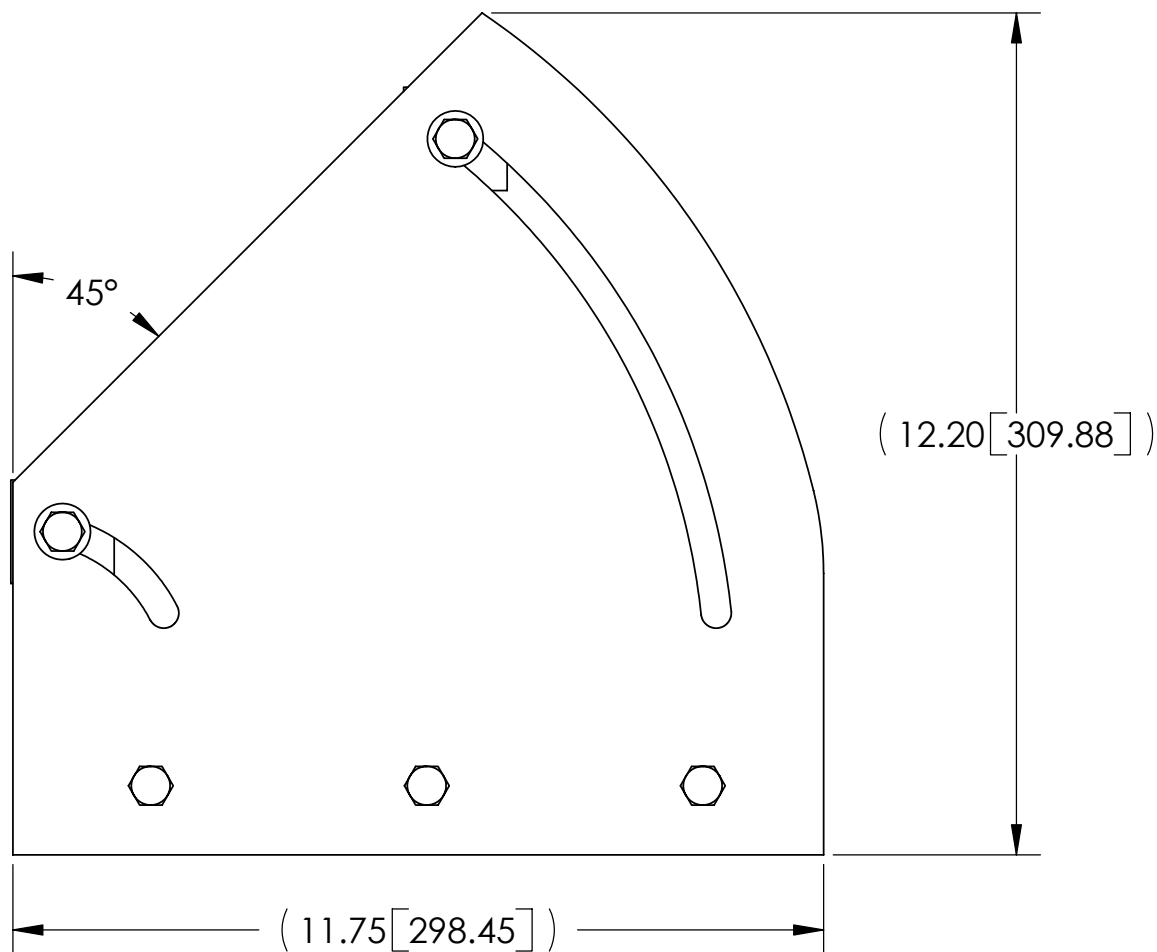

NOTES:
1. ALL METRIC DIMENSIONS ARE IN BRACKETS.

These drawings and specifications are the proprietary property of ANDREW CORPORATION and may be used only for the specific purpose authorized in writing by Andrew Corporation. ALL DIMENSIONS ARE IN INCHES U.O.S. TOLERANCES UNLESS OTHERWISE SPECIFIED: .X = ± .06 ANGLES ±2° .XX = ± .03 FRACTIONS ±1/32 .XXX = ± .010 REMOVE BURRS AND BREAK EDGES .005 DO NOT SCALE THIS PRINT	DRAWN BY: ACG	SHEET: 1 of 1	PART NUMBER: MT-F504
	CHECKED BY: TP	SCALE: NTS	DESCRIPTION: ADJUSTABLE SPLICE KIT
	DATE: 04/20/06	MATERIAL: A568	DRAWING TYPE: ASSEMBLY DRAWING
	REVISION: A	FINISH: GALV A123 WEIGHT: 4.47 LBS	 ORLAND PARK, IL. 60462 U.S.A.