

NOTES:

REVISIONS

| REV. | DESCRIPTION | DATE | APPROVED |
|------|---|-------------|------------|
| A | ECR 8000020467: RELEASE TO PRODUCTION PER EAO 604160. | 27FEB17 RDD | S.LIU/JIHE |

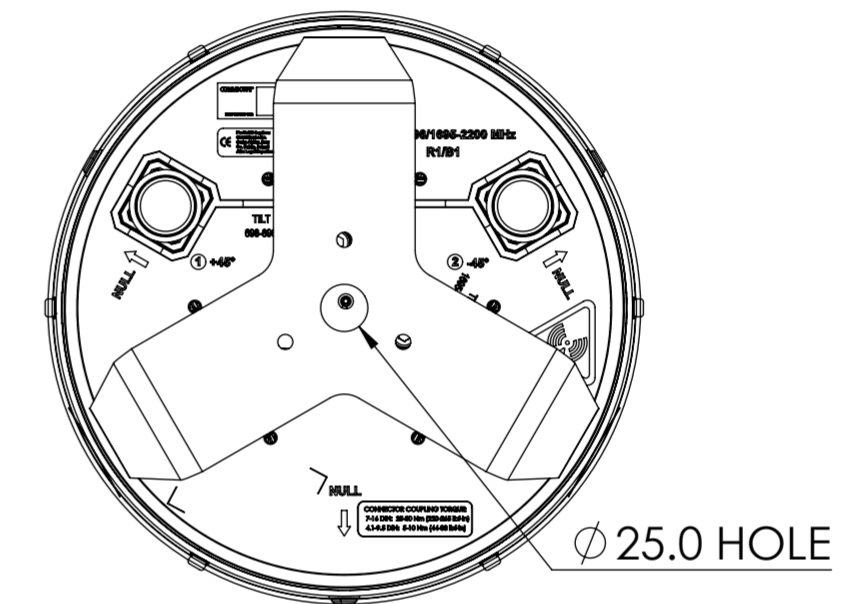
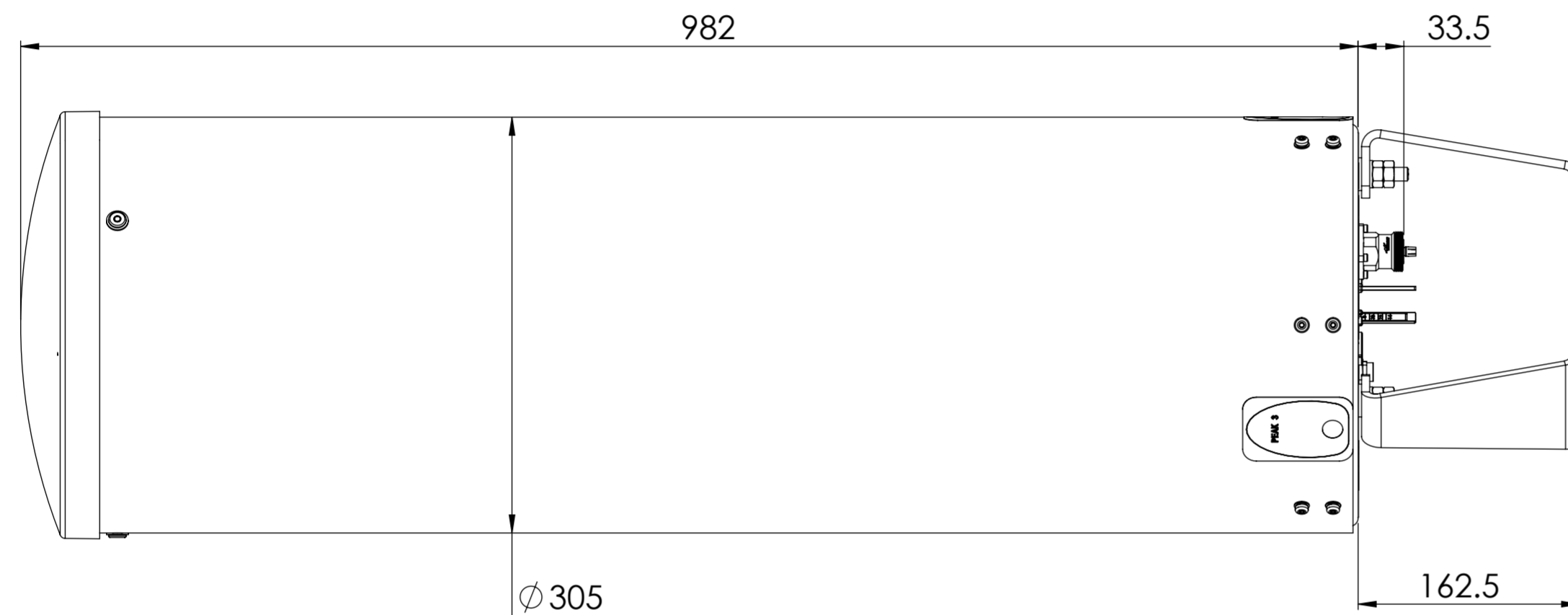

NH360QM-D-2XR

COMMSCOPE, INC. OF NORTH CAROLINA

| TOLERANCES | | | | SAP MATERIAL MASTER | | | | | | | | | | | | | | | | | |
|--|------------|-----------------|-------|---------------------|--------------|---------------|---------------|--------------|-----------------|-----------------|------------|-----------|------------|---------|------------|----------|------------|--|--|--|--|
| 0 PLACE | X ± | 2 PLACE | .XX ± | | | | | | | | | | | | | | | | | | |
| 1 PLACE | .X ± | ANGLES | ± | | | | | | | | | | | | | | | | | | |
| FINISH N/A | | | | MATERIAL N/A | | | | | | | | | | | | | | | | | |
| <table border="1"> <thead> <tr> <th>NAME</th> <th>DATE</th> <th>TITLE</th> </tr> </thead> <tbody> <tr> <td>CE RDD</td> <td>02/28/2017</td> <td rowspan="5">PRODUCT DRAWING</td> </tr> <tr> <td>RW DR1050</td> <td>03/01/2017</td> </tr> <tr> <td>RV CHALIU</td> <td>03/02/2017</td> </tr> <tr> <td>AD JIHE</td> <td>03/03/2017</td> </tr> <tr> <td>RE BYUAN</td> <td>03/05/2017</td> </tr> </tbody> </table> | | | | NAME | DATE | TITLE | CE RDD | 02/28/2017 | PRODUCT DRAWING | RW DR1050 | 03/01/2017 | RV CHALIU | 03/02/2017 | AD JIHE | 03/03/2017 | RE BYUAN | 03/05/2017 | DOCUMENT NO. NH360QM-D-2XR-L | | | |
| NAME | DATE | TITLE | | | | | | | | | | | | | | | | | | | |
| CE RDD | 02/28/2017 | PRODUCT DRAWING | | | | | | | | | | | | | | | | | | | |
| RW DR1050 | 03/01/2017 | | | | | | | | | | | | | | | | | | | | |
| RV CHALIU | 03/02/2017 | | | | | | | | | | | | | | | | | | | | |
| AD JIHE | 03/03/2017 | | | | | | | | | | | | | | | | | | | | |
| RE BYUAN | 03/05/2017 | | | | | | | | | | | | | | | | | | | | |
| ECN 8000020467-O | | | | SCALE 1:4 | | | | | | | | | | | | | | | | | |
| SIZE A2 | | WORK AREA 23 | | MODEL | | DRAWING | | SHEET | | | | | | | | | | | | | |
| | | | | VERSION 00 | STATUS RE | REVISION A | VERSION 00 | STATUS RE | REVISION A | SHEET 1 OF 1 | | | | | | | | | | | |

| | |
|--------------|-------------------|
| DENSITY | g/mm ³ |
| MASS | grams |
| VOLUME | mm ³ |
| SURFACE AREA | mm ² |