

8

7

6

5

4

3

2

1

NOTES:

REVISIONS			
REV	DESCRIPTION	DATE	APPROVED
A	ECR 5079717: REL TO PRODUCTION. EE:TJIE ME:JUNFYU	31OCT08 WQ	JUNFYU/YHUA
D	ECR 8000000229: UPDATE DRAWING.	15MAR13 DYT	EB/GD
E	ECR 8000004542: UPDATE DRAWING.	7/23/14 J.H	LHL/AD
F	ECR 8000006791: UPDATE DRAWING WITH LATEST MODEL.	13FEB15 HWW	S.LIU/JIHE
G	ECR 8000013058: UPDATE DRAWING.	21MAR16 QW	LHL/AD

LNX-6513DS-VTM

THIRD ANGLE PROJECTION

MATERIAL N/A	DENSITY: MASS:	UNLESS OTHERWISE SPECIFIED DIMENSIONS ARE IN MILLIMETERS INTERPRET PER ISO STANDARDS HANDBOOK, TECHNICAL DRAWINGS, VOLUMES 1 & 2, THIRD EDITION (2002)	WESTCHESTER, IL. 60154 U.S.A.	
FINISH N/A	TOLERANCES 0 PLACE X± 1 PLACE .X± 2 PLACE .XX± ANGLES ± ALL SURFACES ✓	THIRD ANGLE PROJECTION		
		PRODUCT DRAWING		
DRAWN BY WQ 31OCT08 ECN 8000013058-O		SIZE <b>A1 84147</b>	CAGE CODE <b>84147</b>	DOCUMENT NO. <b>LNX-6513DS-VTM-L</b>
AUTH. GROUP 23		MODEL	DRAWING	
NOTICE: These drawings and specifications are the proprietary property of ANDREW CORPORATION and may be used only for the specific purpose authorized in writing by Andrew.		VERSION 08	STATUS RE	REVISION J
		VERSION 06	STATUS RE	REVISION G
				SHEET 1 OF 2

8

7

6

THIRD ANGLE PROJECTION

3

2

1

8

7

6

5

4

3

2

1

D

D

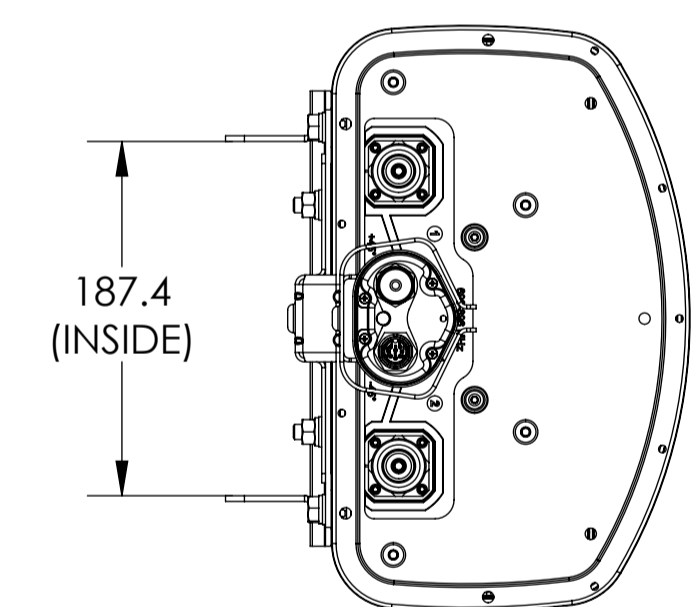
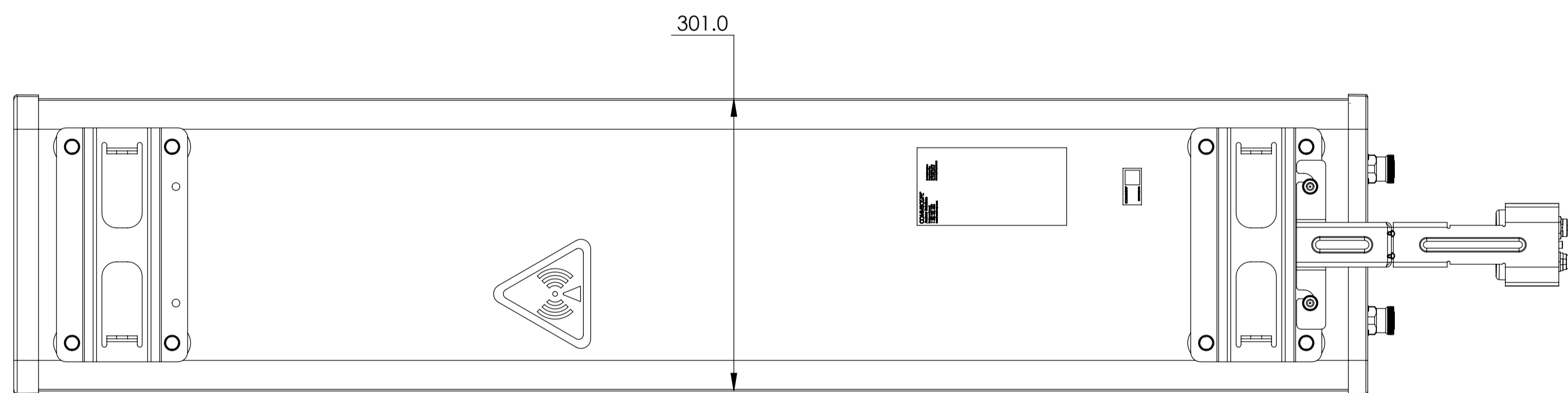
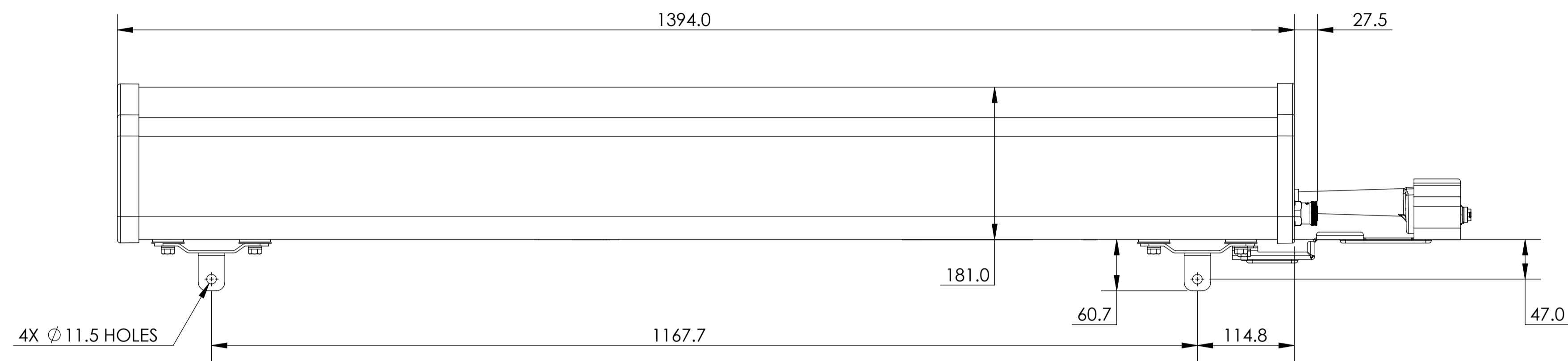

LNX-6513DS-R2M  
LNX-6513DS-A1M

A

A

**ANDREW** WESTCHESTER, IL. 60154  
U.S.A.

PRODUCT DRAWING

THIRD ANGLE PROJECTION	SIZE <b>A1</b>	CAGE CODE <b>84147</b>	DOCUMENT NO. LNX-6513DS-VTM-L
	VERSION 06	STATUS RE	REVISION G
			SHEET 2 OF 2

NOTICE: These drawings and specifications are the proprietary property of ANDREW CORPORATION and may be used only for the specific purpose authorized in writing by Andrew.

8

7

6

THIRD ANGLE PROJECTION

3

2

1