

| CATALOG NO.             | DESCRIPTION         | WEIGHT (lbs.) |
|-------------------------|---------------------|---------------|
| FOT-KIT-TOL-SC/ST CRIMP | SC/ST CRIMPING TOOL | 2.0           |

NOTES:

1. SEE UNIPRISE CATALOG FOR PART NUMBER SUFFIXES TO INDICATE COLOR/PKG.

2. SEE UNIPRISE CATALOG FOR COMPLETE LIST OF PARTS RELATED TO THE USE OF THIS PRODUCT.

3. DIMENSIONS IN PARENTHESES ARE IN METRIC.

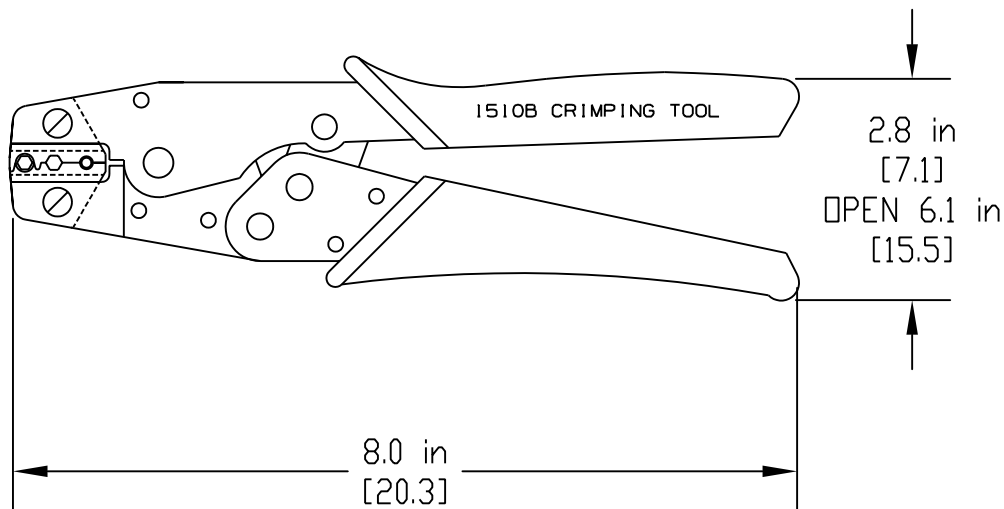

FOT-KIT-TOL-SC/ST CRIMP

COMMSCOPE, INC HICKORY, NORTH CAROLINA

Uniprise

DRAWN BY

DATE

DWG NO.

| REV | DATE | ECR | DESCRIPTION | BY |
|-----|------|-----|-------------|----|
|     |      |     |             |    |