

ITEM	PART NO.	DESCRIPTION	QTY.	WEIGHT
1	CM01	Chain Mount Anchor	4	6.17 LBS
2	CM.03	CHAIN LOCK	4	0.20 LBS
3	CM.04	1/2" X 6" Under Jaw Turnbuckle	4	0.68 LBS
4	GWL-04	1/2" GALV LOCK WASHER	4	0.09 LBS
5	GN-04	1/2" GALV HEX NUT	4	0.04 LBS
6	G40192	CHAIN 192" LONG	4	12.00 LBS
7	PMSL05	14" L-Bracket	2	13.44 LBS
8	GB-0522A	5/8" X 2-1/4" GALV BOLT KIT (A325)	4	0.15 LBS
9	GUB-4456	1/2" X 4-5/8" X 6-1/2" GALV U-BOLT	4	0.57 LBS
10	MT-653-63	4.5" O.D. X 63" SCH 40 PIPE	SEE TABLE	-

REVISIONS				
REV.	ZONE	DESCRIPTION	BY	DATE
A		INITIAL RELEASE	DRR	11/15/11
B		REVISED CONTENTS OF -B KIT	DRR	02/20/12

PART NUMBER	WEIGHT	PIPE	QTY	WEIGHT
CML-H60-B	78.7	NONE	-	109.37 LBS
<b>CML-H60-63</b>	<b>135.0</b>	<b>MT-653-63</b>	<b>1</b>	<b>165.72 LBS</b>

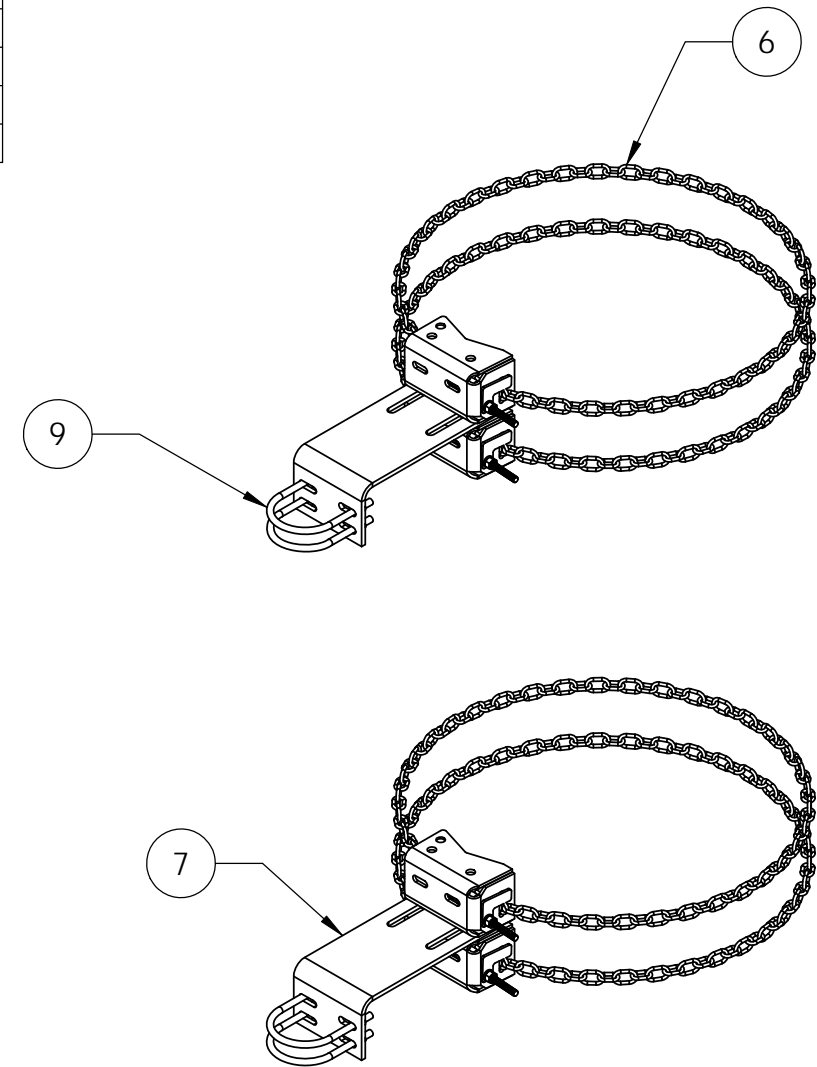
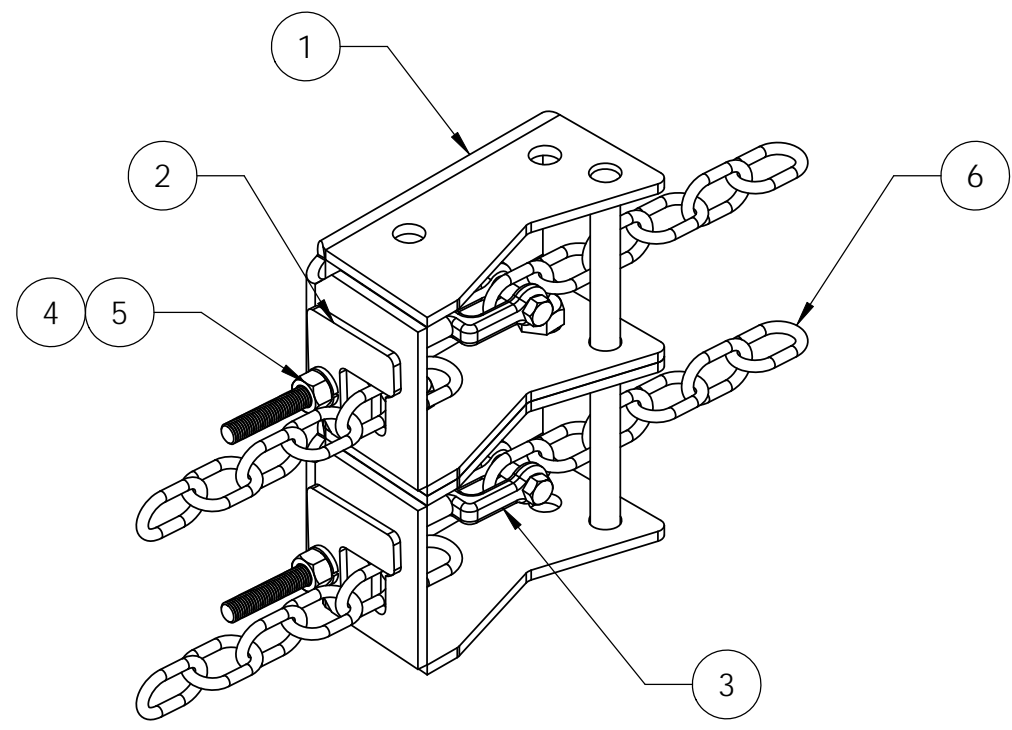

**CML-H60-B**

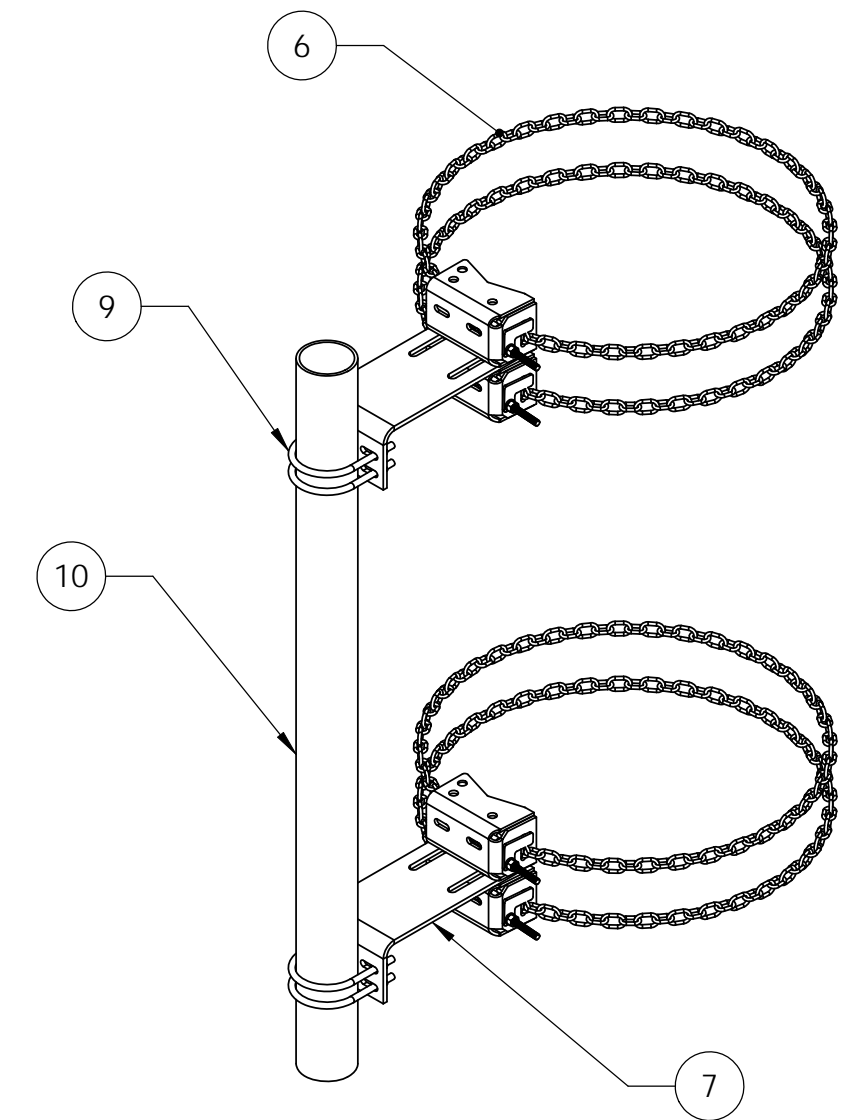

**CML-H60-63**

**NOTES:**

- ATTACH THE PIPES OR PIPE MOUNTS TO THE BRACKETS PRIOR TO ADDING THE JAW-BOLT/CHAIN ASSEMBLY.
- FOR ROUND MEMBERS  $\phi 10''$  TO  $\phi 60''$

<small>These drawings and specifications are the proprietary property of ANDREW CORPORATION and may be used only for the specific purpose authorized in writing by Andrew Corporation.</small> ALL DIMENSIONS ARE IN INCHES U.O.S. TOLERANCES UNLESS OTHERWISE SPECIFIED: .X = $\pm .12$ ANGLES $\pm 2'$ .XX = $\pm .06$ FRACTIONS $\pm 1/32$ .XXX = $\pm .03$ REMOVE BURRS AND BREAK EDGES .005 DO NOT SCALE THIS PRINT	DRAWN BY: <b>DRR</b>	SHEET: 1 of 1	PART NUMBER: <b>CML-H60 SERIES</b>
	CHECKED BY: <b>TP</b>	SCALE: NTS	DESCRIPTION: <b>HEAVY DUTY STANDOFF CHAIN MOUNT</b>
	DATE: 11/15/11	MATERIAL: A36,A500	DRAWING TYPE: ASSEMBLY DRAWING
	REVISION: <b>B</b>	FINISH: GALV A123	 WESTCHESTER, IL. 60154 U.S.A.
	WEIGHT: SEE TABLE		