

Toolless Re-Enterable Aerial Closure

Product Description

The TRAC closure is an easily installed closure system for free-breathing aerial applications. It is designed to handle straight and branch configurations of polyethylene-insulated cables. A TRAC extension closure kit may be used to extend the TRAC closure to accommodate extended sheath openings.

TRAC closure tape wrap is a closed cell foam tape. It is used to close up the end piece opening when there is a butt splice and when two cables are exiting one cable port. TRAC closure tape wrap is available in 60-inch rolls or 12-inch strips.

The TRAC AA drain closure is used for mid-span drain applications and sheath repair.

Caution

Use company-approved safety practices and equipment when installing the TRAC aerial closure.

Kit Components

The following are the standard kit components for most TRAC aerial closure kits:

- A. Body
- B. Installation instructions
- C. End pieces (2 each)
- D. Tie wraps for central body hinge (2 each)
- E. SSB or RB Bond assembly (SSB shown)
- F. Bond clamps (optional)

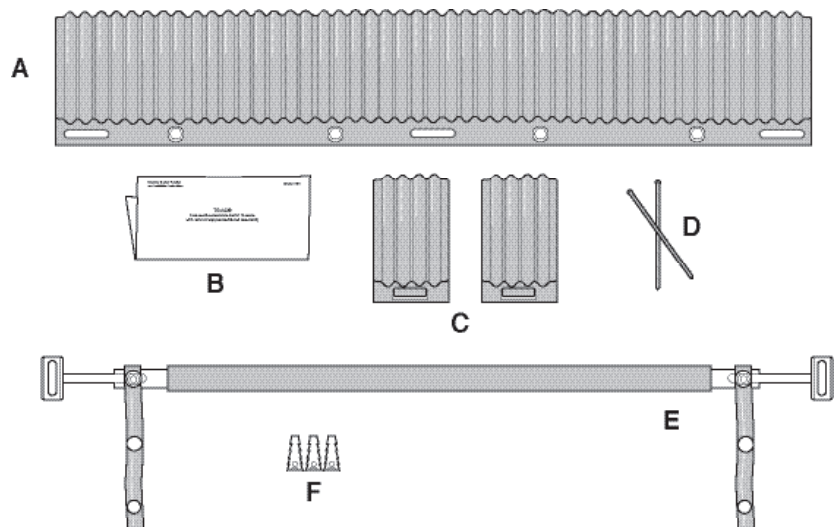

General Installation

1. Refer to the table on page 4 for maximum sheath openings. Remove sheath and place approved bond clamps 90° from the top of the cables. (see A)
2. Hang and secure bond assembly to the strand. Attach flexible bond straps to the bond clamps. Place spacers per locally approved practice. Spacers must be used 2-inches from each end of the closure to align cables. Perform splice operation and secure splice to the bond assembly with cable ties. (see B)

Note: On self-supporting cable, it is not necessary to remove the insulation from the strand.

Note: On B+, C, and D installations, support the cables at each end of the bond bar assembly with 1/2 - 1 inch spacers placed under the bar.

3. Using diameter tape on these instruction sheets, measure cable O.D. to determine if gel trimming is required. (see C) Refer to the gel trimming criteria on page 4.
4. If gel trimming is required, follow the cut guides on the gel at the locations shown. (see D)
5. Position the end piece over the hanger bracket. Center the cables through the ports of the end pieces. Press half shells together at branch cable to engage latch. (see E)
6. Place the central body over the end pieces and align the outside edges of the central body. Close the central body over the splice and fasten the latches or bolts. (see F)
7. Place the short tie wraps in the hinge slots of the central body and end pieces. Leave an 1/2-inch loop in the tie wrap. (see G)

Note: For the RB bond assembly secure the completed closure directly to the strand using company-approved supports.

Re-entry

1. Release latches/bolts and roll the central body back over the cable to access the wirework. (see H)
2. If more working room is needed, one of the tie wraps on either end may be removed to allow the central body to hang vertically from one end. (see I)

Note: It is not necessary to remove the end pieces unless an additional cable is placed. Only reuse the end piece if the same size or larger cable is used.

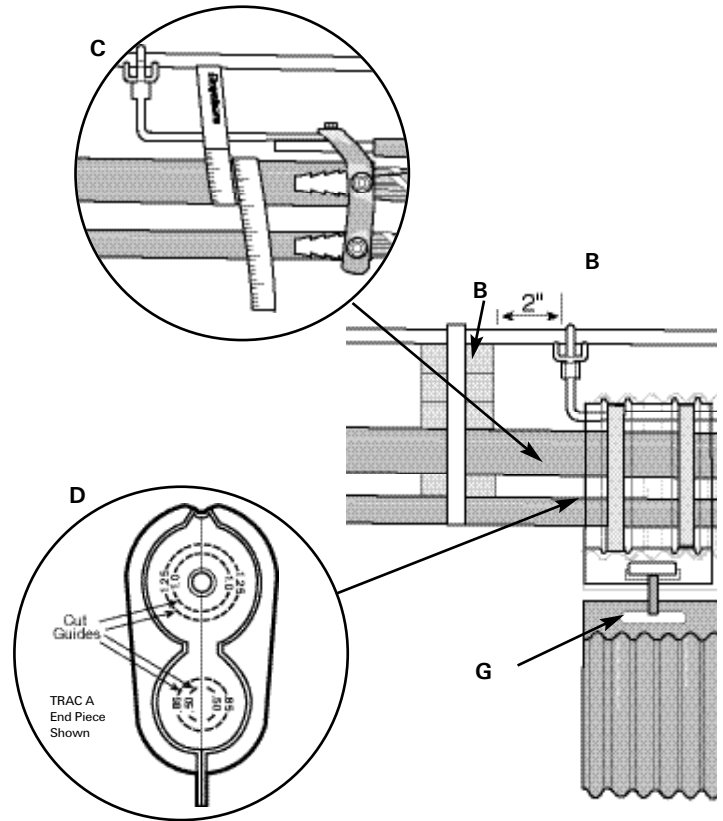

Two Cables Exiting One Cable Port

Note: The OD of the two cables plus the TRAC closure tape must be in the application range of the closure you are using. See cable OD Range on page 4.

Caution: Do not substitute "B" sealing tape or other materials for TRAC closure tape wrap. TRAC closure tape wrap was carefully formulated for use with the TRAC aerial closures.

Remove the TRAC closure central body. Determine which end the additional cable will enter and mark the position of the end piece on the cables. Remove the end piece and wrap the sealing rolls as follows:

1. Cut two pieces of TRAC closure tape wrap, remove the backing and make the necessary sealing rolls as shown. (see J)
2. Place the sealing roll on the bottom cable centered between the end piece marks on the cable. Butt the sealing tape ends. (see K)
3. Cut a 12-inch piece of TRAC tape wrap and remove the backing. Starting with the top cable, wrap the cables tightly as shown. Compress with hand. (see L)

Butt Splice

1. For butt splice applications, make a TRAC closure tape wrap roll to fill hole in the top of end piece as shown (see M) or use TRAC EP plugs. TRAC AA and A end pieces require one small. (see N) TRAC B and B+ end pieces require two medium and TRAC C and D end pieces requires two large. (see O)

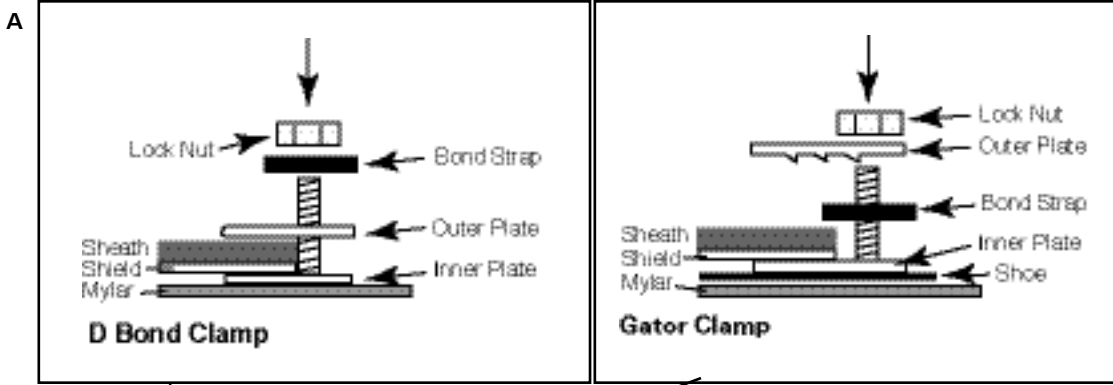

NOTE: B Bond Clamp requires slitting sheath and shield for inner plate.

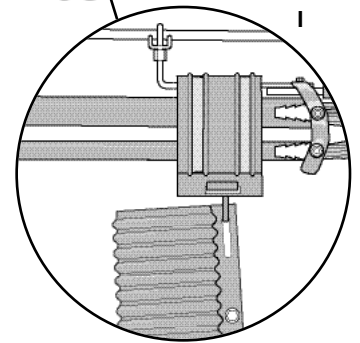
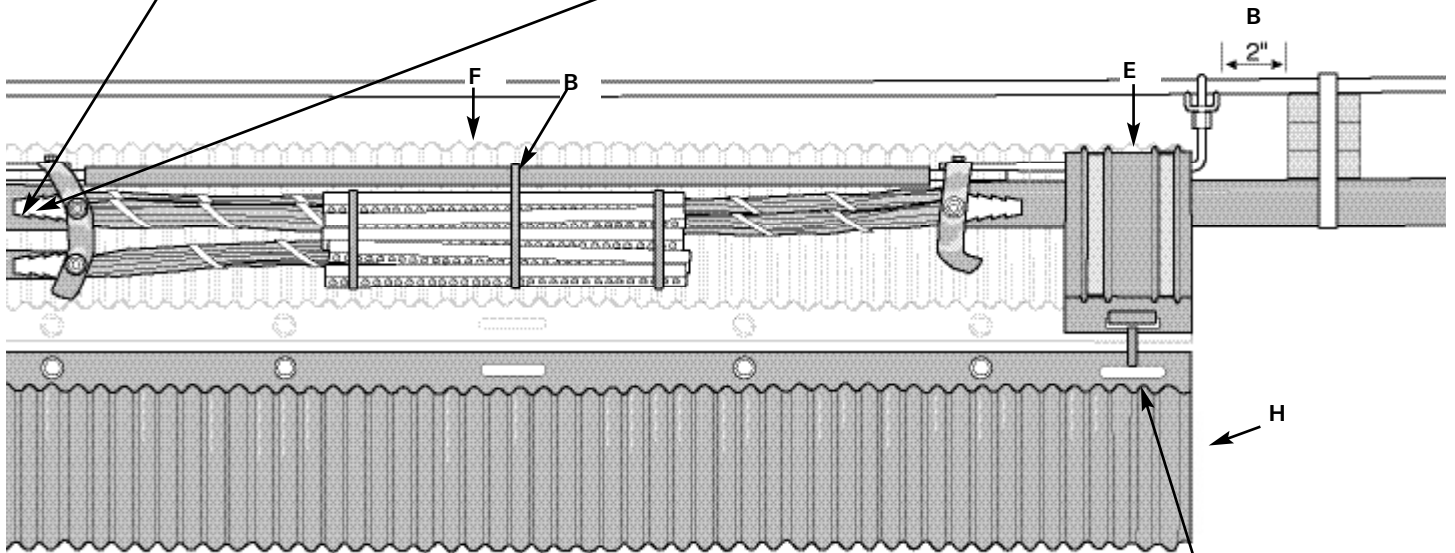

TRAC Tape Wrap



TRAC AA, A (Single Wrap)



TRAC B, B+, C (Double Wrap)

N

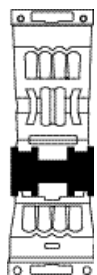

O



J

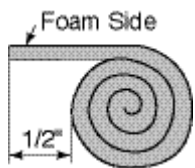

K



L



M

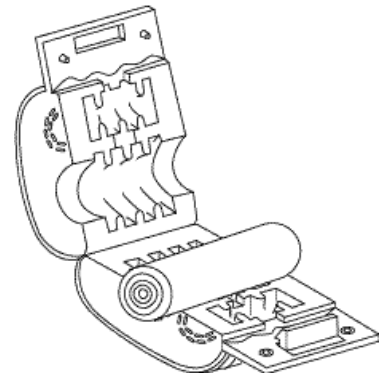

Product	Max. Splice Bundle Diameter	Sheath Opening	Number of Cable Ports (in/out)	Cable Port	Cable OD Range	If CableTrim OD is (in)	Gel at Mark
TRAC AA-1 Sheath repair	2	17	1/1	Main	.4 - 1.25	.4 - .9 1.0 - 1.25	Don't Trim 1.0
TRAC AA Drain	n/a	n/a	1/1		.4 - 1.25	.4 - .9 1.0 - 1.25	Don't Trim 1.0
TRAC AA Strand support bond	2	9, 17	2/2	Main	.4 - .9	.4 - .7 .8 - .9	Don't Trim .8
TRAC AA Rigid bond		12,20		Branch	0 - .5	0 - .5	Don't Trim
TRAC A Strand support bond	3	17	2/2	Main	.5 - 1.5	.5 - .9 1.0 - 1.2 1.3 - 1.5	Don't Trim 1.0 1.25
TRAC A Rigid bond		20		Branch	0 - 1.0	0 - .4 .5 - .8 .9 - 1.0	Don't Trim .50 .85
TRAC B Strand support bond	5	22	2/2	Main	1 - 1.9	1.0 - 1.1 1.2 - 1.5 1.6 - 1.9	Don't Trim 1.2 1.6
TRAC B Rigid bond		25		Branch	0 - 1.5	0 - .7 .8 - 1.1 1.2 - 1.5	Don't Trim .8 1.2
TRAC B+	7	22	2/2	Main	1.25 - 2.6	1.25 - 1.4 1.5 - 2.0 2.1 - 2.6	Don't Trim 1.5 2.1
				Branch	0 - 2.6	0 - .8 .9 - 1.4 1.5 - 2.0 2.1 - 2.6	Don't Trim .9 1.5 2.1
TRAC B+ (3-Way)	7	22	3/3	Main	1.25 - 1.9	1.25 - 1.5 1.6 - 1.9 0 - .9	Don't Trim 1.6 Don't Trim
				Branch 1 and 2	0 - 1.3	1.0 - 1.3	1.0
TRAC C	9	22	3/3	Main**	1.25 - 3.3	1.25 - 2.0 2.1 - 2.4	Don't Trim 2.1
TRAC D	12	22	3/3			2.5 - 2.8 2.9 - 3.3	2.5 2.9
				Branch 1*	0 - 2.75	0 - .4 .5 - 1.4 1.5 - 1.9 2.0 - 2.75	Don't Trim .5 1.5
				Branch 2***	0 - 1.5	0 - .4 .5 - 1.0 1.1 - 1.5	Don't Trim .5 1.1

* If cable diameter is 2.2 - 2.75", trim out internal gel ribs.

** Maximum cable diameter is 2.8" if Branch 1 cable diameter is larger than 2.2"

*** Maximum cable diameter is 1.2" if Branch 1 cable diameter is larger than 2.2".

TRACE and TRAC are trademarks of CommScope Inc

The information given herein, including drawings, illustrations and schematics which are intended for illustration purposes only, is believed to be reliable. However, CommScope makes no warranties as to its accuracy or completeness and disclaims any liability in connection with its use. CommScope's obligations shall only be as set forth in CommScope's Standard Terms and Conditions of Sale for this product and in no case will CommScope be liable for any incidental, indirect or consequential damages arising out of the sale, resale, use or misuse of the product. Users of CommScope products should make their own evaluation to determine the suitability of each such product for the specific application.

Technical Assistance Center (TAC)
Tel.: 800.830.5056
Email: TAC.Americas@commscope.com
www.commscope.com