

Fiber Distribution Hub

FDH 3000

288 Cabinet With Splicing

User Manual

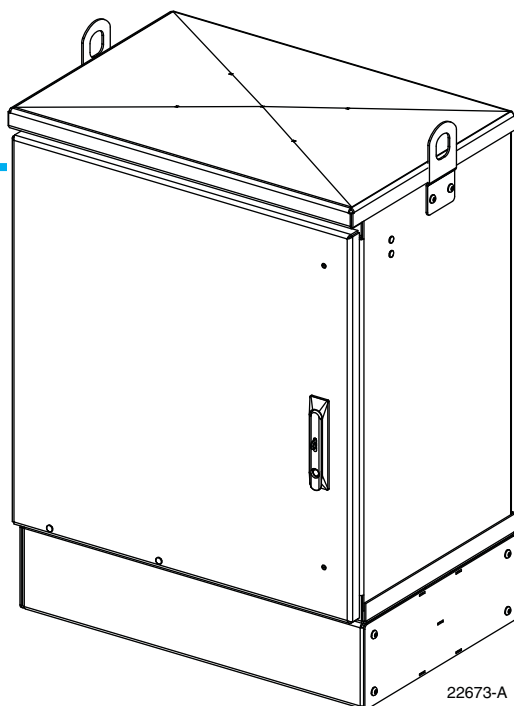

22673-A

ADCP-96-139
Rev B, July 2017

COPYRIGHT

© 2017, CommScope Inc.
All Rights Reserved

REVISION HISTORY

ISSUE	DATE	REASON FOR CHANGE
1	3/2008	Original.
B	July 2017	Updated to CommScope format.

TRADEMARK INFORMATION

CommScope, CommScope(logo), and NG4access are registered trademarks of CommScope, Inc.

ADC and ADC Telecommunications are registered trademarks of CommScope, Inc.

Telcordia is a registered trademark of Telcordia Technologies, Inc.

GORE is a registered trademark of W. L. Gore & Associates, Inc.

DISCLAIMER OF LIABILITY

Contents herein are current as of the date of publication. CommScope reserves the right to change the contents without prior notice. **In no event shall CommScope Inc. be liable for any damages resulting from loss of data, loss of use, or loss of profits and CommScope Inc. further disclaims any and all liability for indirect, incidental, special, consequential or other similar damages. This disclaimer of liability applies to all products, publications and services during and after the warranty period.**

This publication may be verified at any time by contacting CommScope's Technical Assistance Center at 1.800.830.5056, or by e-mail to TAC.Americas@commscope.com.



ABOUT THIS MANUAL

This publication describes the OmniReach FDH 3000 288 cabinet with splicing. Also included are procedures for mounting the cabinet, installing and splicing feeder and distribution cables, installing additional splitter modules, installing additional distribution panels, storing the splitter output fibers, connecting the splitter output fibers to the distribution fibers, and replacing damaged components.

RELATED PUBLICATIONS

Listed below are related manuals and their publication numbers. Copies of these publications can be ordered on the CommScope website at the following URL:

<http://www.commscope.com/SupportCenter>

Title	ADCP Number
Optical Fiber Connector Wet and Dry Cleaning Instructions	90-159
Plug And Play Splitter Installation Guide	96-087
Round Splice Tray Cable Routing Instructions	90-321
Breakout and Moisture Blocking Kit for Dielectric Uni-Tube Cable Instructions	93-064
Breakout and Moisture Blocking Kit for Armored Uni-Tube Cable Instructions	93-039

ADMONISHMENTS

Important safety admonishments are used throughout this manual to warn of possible hazards to persons or equipment. An admonishment identifies a possible hazard and then explains what may happen if the hazard is not avoided. The admonishments — in the form of Dangers, Warnings, and Cautions — must be followed at all times. These warnings are flagged by use of the triangular alert icon (seen below) and are listed in descending order of severity of injury or damage and likelihood of occurrence.



Danger: *Danger is used to indicate the presence of a hazard that **will** cause severe personal injury, death, or substantial property damage if the hazard is not avoided.*



Warning: *Warning is used to indicate the presence of a hazard that **can** cause severe personal injury, death, or substantial property damage if the hazard is not avoided.*



Caution: *Caution is used to indicate the presence of a hazard that **will** or **can** cause minor personal injury or property damage if the hazard is not avoided.*

GENERAL SAFETY PRECAUTIONS



Warning: *Wet conditions increase the potential for receiving an electrical shock when installing or using electrically-powered equipment. To prevent electrical shock, never install or use electrical equipment in a wet location or during a lightning storm.*



Danger: *Do not look into the ends of any optical fiber. Exposure to laser radiation may result. Do not assume the laser power is turned-off or that the fiber is disconnected at the other end.*



Danger: *Use adequate lifting equipment when moving or installing Fiber Distribution Hub cabinets. Verify that the maximum lift weight rating of the equipment is sufficient to handle the weight of the cabinet.*



Danger: *Do not stand under a Fiber Distribution Hub cabinet as it is being hoisted into position for mounting. A failure of the lifting equipment or apparatus could result in serious personal injury and cause significant damage to the cabinet.*



Warning: *Before digging, check with all local utilities for the presence of buried cables or pipes. Contact with underground cables or pipes, especially electric power cables and gas service lines, could interrupt local utility service and cause serious personal injury and extensive property damage.*

STANDARDS CERTIFICATION

Telcordia: This equipment complies with the applicable sections of GR-3125-CORE

LIST OF ACRONYMS AND ABBREVIATIONS

The acronyms and abbreviations used in this manual are detailed in the following list:

AWG	American Wire Gauge
C	Centigrade
F	Fahrenheit
FDH	Fiber Distribution Hub
FMS	Mounting Sleeve
FTTP	Fiber To The Premises
OSP	Outside Plant
PMF	Pad Mount Frame
PNP	Plug and Play

TABLE OF CONTENTS

Content	Page
About This Manual	iii
Related Publications	iii
Admonishments	iii
General Safety Precautions	iv
Standards Certification	iv
List of Acronyms and Abbreviations	iv
1 DESCRIPTION	1
1.1 General Description	1
1.2 Main Components	2
1.3 Specifications and Dimensions	3
2 BEFORE STARTING THE INSTALLATION	5
2.1 Installation Overview	5
2.2 Unpacking and Inspection	5
2.3 Cabinet Installation Hardware	6
2.4 OSP Cable and Cabinet Grounding Cables	6
2.5 Tools and Materials Required for Installation	6
2.6 Cabinet Mounting	7
3 MOUNTING THE CABINET ON A MOUNTING SLEEVE	7
3.1 Installation Recommendations	8
3.2 Excavation	8
3.3 Placement of the FMS	9
3.4 Cable Conduit Installation	10
3.5 Grounding System Installation	10
3.6 Back Fill	10
3.7 Mounting the Cabinet on the FMS	10
3.8 Grounding Wire Connection To Cabinet	13
4 MOUNTING THE CABINET ON A CONCRETE PAD	14
4.1 Installation Recommendations	14
4.2 Base Construction and Conduit Installation	14
4.3 Concrete Pad Construction	16
4.4 Grounding System Installation	17
4.5 Mounting the Cabinet on the Concrete Pad	17
4.6 Grounding Wire Connection To Cabinet	20
5 FEEDER CABLE INSTALLATION AND SPLICING	20
5.1 Cable Bracket Cover Removal/Installation	21
5.2 Feeder Cable Installation	21
5.3 Grounding the Feeder Cable	24
5.4 Splicing the Feeder Cable Fibers	26
6 DISTRIBUTION CABLE INSTALLATION AND SPLICING	30
6.1 Distribution Cable Installation	30
6.2 Grounding the Distribution Cables	32

TABLE OF CONTENTS

Content	Page
6.3 Splicing the Distribution Cable Fibers	35
7 PLUG AND PLAYER SPLITTER MODULE INSTALLATION	41
8 ROUTING AND CONNECTING THE SPLITTER OUTPUT FIBERS	43
8.1 Storing The Splitter Output Fibers	43
8.2 Enabling Service To a Subscriber	44
9 PASS-THROUGH ROUTING PROCEDURES	45
9.1 Sliding Adapter Pack Pass-Through Routing Procedure	45
9.2 Splitter Compartment Pass-Through Routing Procedure	46
10 MAINTENANCE AND REPAIR PROCEDURES	48
10.1 Painting.	48
10.2 Distribution Panel Adapter Replacement	48
10.3 Splitter Compartment Adapter Replacement	50
10.4 Replacing a Damaged Fiber or Connector.	51
10.4.1 Splitter Output Fiber Connector Replacement	52
10.5 Door Gasket Replacement	52
10.6 Door Replacement	52
10.7 Grounding System Terminal Access Procedure	54
11 CUSTOMER INFORMATION AND ASSISTANCE	56

1 DESCRIPTION

1.1 General Description

The 288 cabinet with splicing is a secure, above-ground, outdoor fiber optic distribution cabinet that is designed to hold the various optical components required for Fiber To The Premises (FTTP) distribution network applications. The cabinet is designed for pedestal-mount applications. [Figure 1](#) shows a typical cabinet.

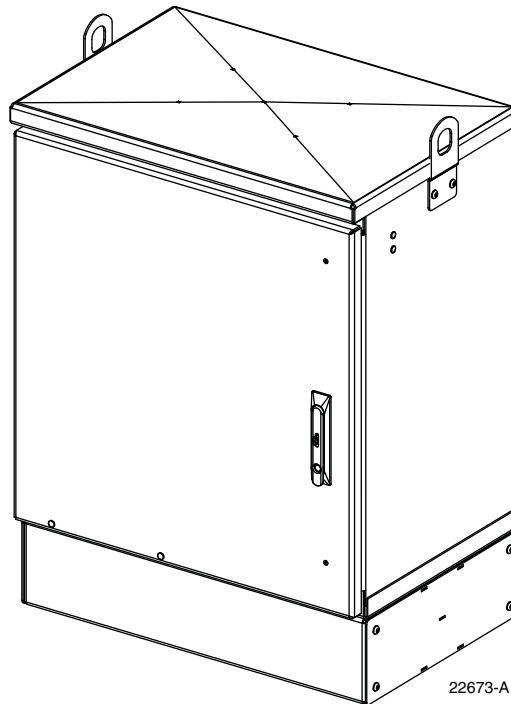

Figure 1. Typical Cabinet

The cabinet may be mounted on a concrete pad or on a mounting sleeve. Mounting kits (accessories) are available for each mounting option. The feeder and distribution cables (stranded cable only) enter/exit the cabinet from the bottom.

Clamps are provided for securing the cables to the inside of the cabinet. The bottom of the cabinet is enclosed with a moisture barrier. The cable entry/exit hole is fitted with a flexible membrane to resist the entry of dust, moisture, and insects. GORE membrane vents are provided to release any moisture that may accumulate within the cabinet.

The exterior shell of the cabinet is constructed of heavy gauge aluminum and is coated with an almond-colored finish. Each cabinet is equipped with a single front door equipped with a tamper-resistant latch, padlock hasp, stainless steel hinges, and door catches that prevent accidental closing. Access to the cabinet requires a 216B key tool (accessory) to release the latch handle. Lifting eyes are provided for hoisting the cabinet into position for mounting. Each cabinet is equipped with a 6-inch ground spacer/riser for extra ground clearance. An additional spacer/riser (accessory item) can be installed if even more ground clearance is required.

1.2 Main Components

Figure 2 shows the main components of a typical 288 cabinet with splicing. Included are:

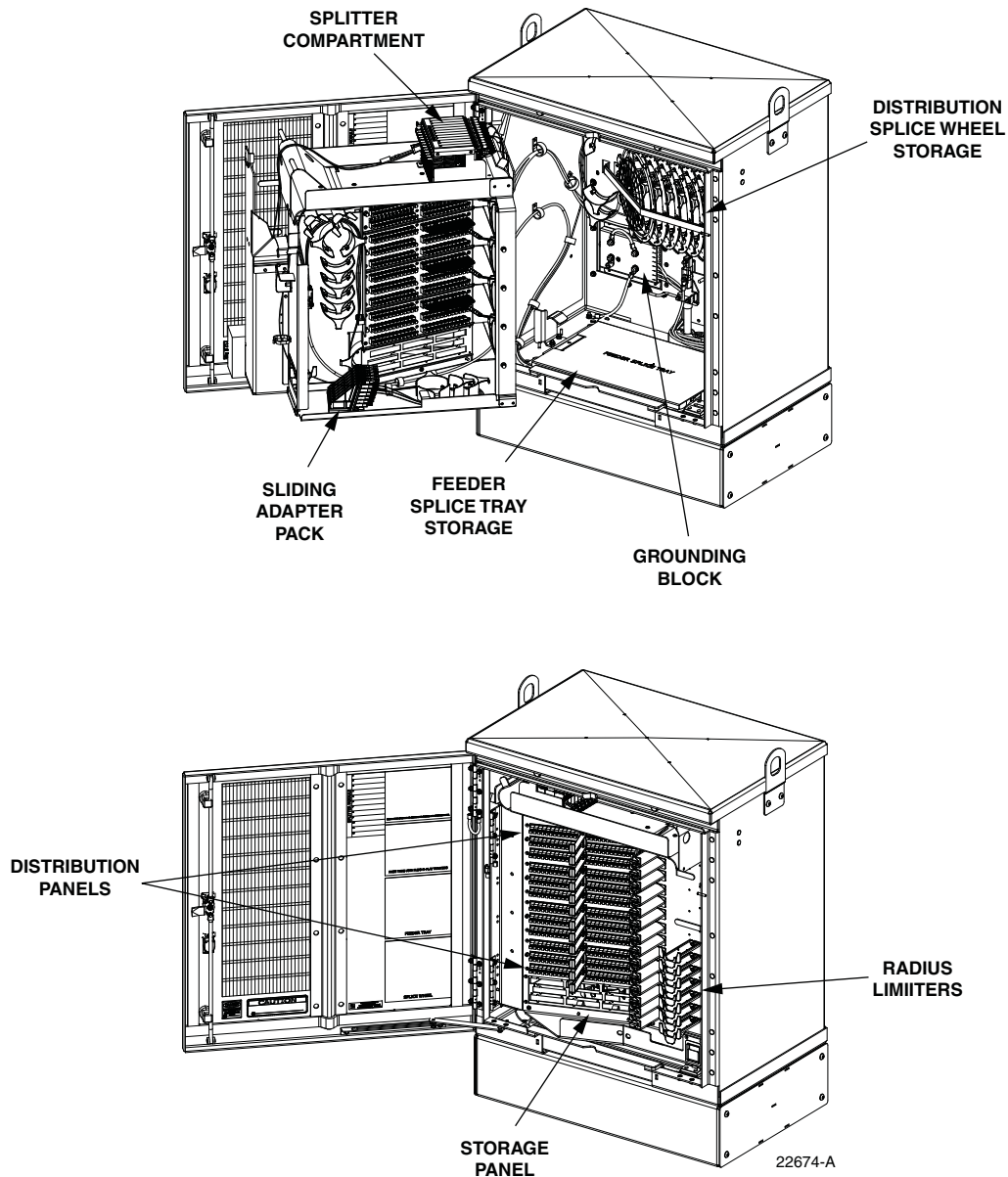

Figure 2. Main Components of a Typical 288 Cabinet With Splicing

- **Distribution Panels:** Provide a point for connecting the splitter output fibers with the terminated distribution cable fibers. Each panel provides mounting spaces for 72 bulkhead adapters. The cabinet may be ordered with one to six distribution panels installed. Additional panels may be ordered and installed as needed. UPC/SC or APC/SC style connectors are available.

- **Storage Panel:** Provides a temporary “parking lot” for unused splitter output fibers. Each splitter module comes with a connector pack that mounts in the storage panel. Up to nine 8-position connector packs (72 fibers total) can be mounted in the storage panel.
- **Radius Limiters:** Provide a place for storing excess slack from the splitter output fibers.
- **Splitter Compartment:** Provides a place for mounting the splitters. Will support up to 12 splitters. Unused splitter slots can be used for pass-through fibers. The splitters specified for use with the FDH 3000 cabinet are equipped with bend-optimized fibers.
- **Sliding Adapter Pack (Input panel):** Provides a place for terminating spare feeder cable fibers. Will support up to 36 adapters. Spare feeder cable fibers are typically used for signal pass-through functions.
- **Grounding Block:** Provides a point for grounding the cabinet and OSP cables.
- **Feeder Cable Splice Tray Storage:** Provides storage for one or two 5 x 11.75 inch rectangular splice trays which are used for splicing the feeder cable fibers to the splitter input pigtailed. Each stranded cable splice tray provides storage for up to 36 splices.
- **Distribution Cable Splice Tray Storage:** Provides storage for up to thirty-six round splice trays which are used for splicing the distribution cable fibers to the distribution panel pigtailed. Each stranded cable splice tray provides storage for up to twelve splices.

1.3 Specifications and Dimensions

Table 1 lists the specifications for the FDH 3000 288 cabinet. Figure 3 shows dimensions.

Table 1. 288 Cabinet With Splicing Specifications

PARAMETER	SPECIFICATION
Cabinet	
Dimensions (H x W x D) Pedestal-Mount (See Figure 3)	36.0 x 26.8 x 18.2 inches (91.3 x 68.1 x 46.2 cm)
Weight (fully loaded)	208 lbs (94.3kg)
Certification (pending)	GR-3125-CORE
Distribution panels (maximum)	4
Distribution ports	Up to 288 with four 72-port distribution panels.
Distribution port adapters/connectors	UPC/SC or APC/SC,
Splitter compartment splitter capacity	12 splitters
Splitter compartment adapter capacity	24 adapters
Storage panel capacity	72 connectors
Sliding adapter pack capacity	36 adapters
Splitter Modules	
Splitter module input and output pigtailed	Bend-optimized fiber terminated with UPC/SC or APC/SC connectors
Test bandpass	1260–1360 nm, 1480–1500 nm, 1550–1560 nm

Table 1. 288 Cabinet With Splicing Specifications, continued

PARAMETER	SPECIFICATION
Overall bandpass	1260–1625 nm
Return loss at test bandpass	≥55 dB
Maximum insertion loss at test bandpass	Note: Includes loss from input and output connectors
1 x 2	4.1 dB with UPC, 4.3 with APC
1 x 4	7.6 dB with UPC, 7.8 dB with APC
1 x 8	10.7 dB with UPC, 10.9 dB with APC
1 x 16	13.9 dB with UPC, 14.1 dB with APC
1 x 32	17.1 dB with UPC, 17.3 dB with APC
1 x 64	20.8 dB with UPS, 21 dB with APC
2 x 16	14.5 dB with UPC, 14.7 dB with APC
2 x 32	17.8 dB with UPC, 18 with APC

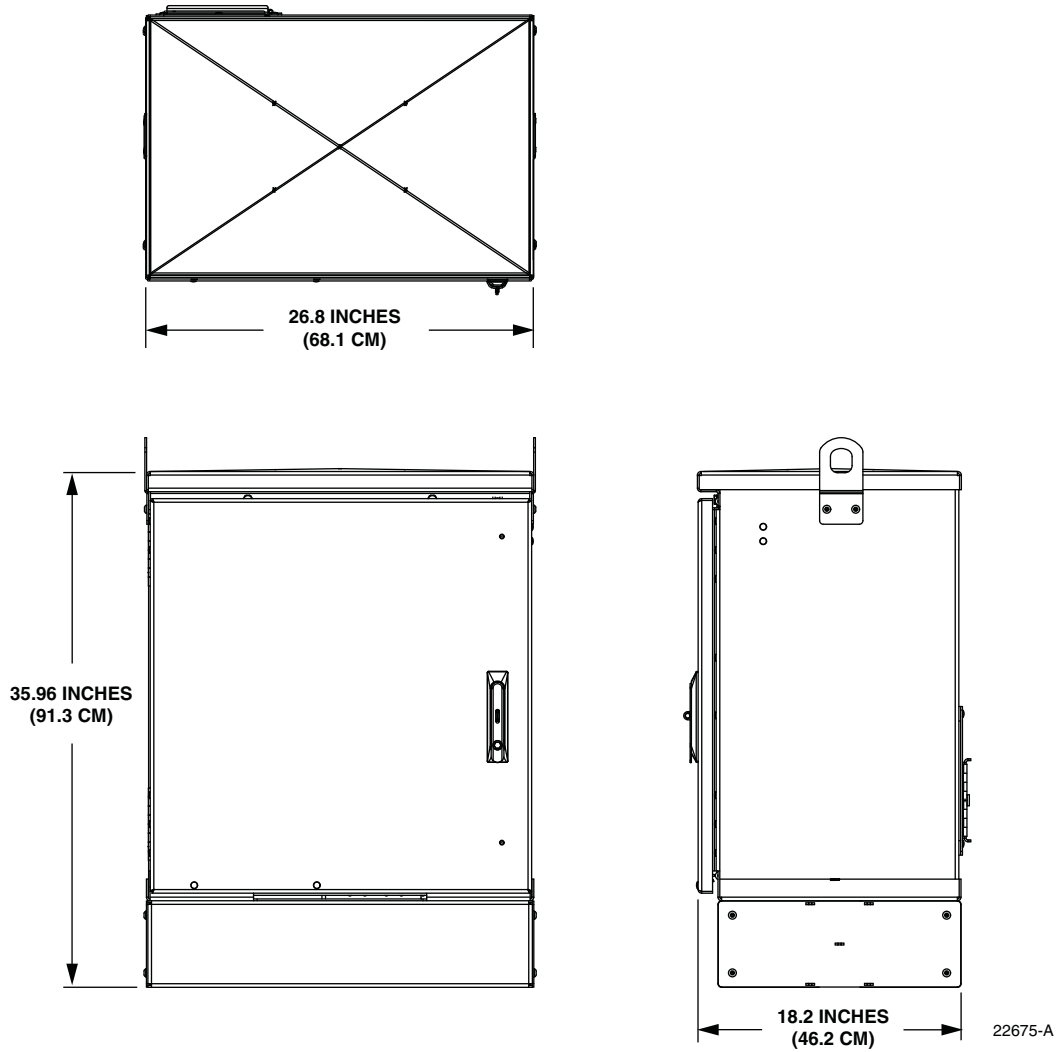

Figure 3. Typical 288 Cabinet With Splicing

2 BEFORE STARTING THE INSTALLATION

2.1 Installation Overview

Installation of the 288 cabinet with splicing involves the following main tasks:

Mounting the Cabinet – The cabinet must be mounted on a support base. The following two mounting options are available:

- **Mounting Sleeve (FMS)** – The FMS is a polymer concrete sleeve that mounts in the ground. The FMS provides a stable mounting platform plus storage space under the cabinet for OSP cable slack. The FMS may also be used as a splicing vault for OSP cables.
- **Poured Concrete Pad** – Concrete base with Pad Mounting Frame (PMF). The PMF is a stainless-steel frame that is embedded in the concrete during installation of the pad. The cabinet attaches to the PMF which holds it securely to the pad.

Splitter Installation – The cabinet may be ordered with one or two splitters. If additional splitters are required, they must be ordered separately. All splitter modules that are ordered separately must be installed in the splitter compartment.

Feeder Cable Installation – The feeder cable must be routed to the cabinet and spliced to the splitter input fibers.

Distribution Cable Installation - The distribution cables must be routed to the cabinet and spliced to the distribution panel pigtails.

Splitter Output Fiber Connections – Service is enabled by connecting the splitter output fiber connectors to the subscriber distribution ports. Unused output fibers are temporarily “parked” in the storage panel until they are needed for service.

2.2 Unpacking and Inspection

Use the following procedure to unpack and inspect the cabinet and all accessories:

1. Inspect the exterior of the shipping container(s) for evidence of rough handling that may have damaged the components in the container.
2. Unpack each container while carefully checking the contents for damage and verify with the packing slip.
3. If damage is found or parts are missing, file a claim with the commercial carrier and notify ADC Customer Service. Save the damaged cartons for inspection by the carrier.
4. Refer to [Section 11](#) of this manual if you need to contact ADC.
5. Save all shipping containers for use if the equipment requires shipment at a future date.

2.3 Cabinet Installation Hardware

The cabinet is shipped with various parts (see [Table 2](#)) for securing the cabinet to the FMS or PMF. Verify that the specified cabinet installation hardware is received.

Table 2. Cabinet Installation Hardware

ITEM	QUANTITY
3/8 x 1-inch hex head capscrews	4
3/8-inch flat washers	4
3/8-inch lock washers	4
Isolation gasket	1

2.4 OSP Cable and Cabinet Grounding Cables

The cabinet is equipped with a common grounding block that is used to tie together all the components of the cabinet that must be grounded. The cabinet itself and any OSP cables with metallic strength members must be connected to an earth ground source. Information on grounding is provided in the sections that cover cabinet mounting.

2.5 Tools and Materials Required for Installation

The following tools and materials are required for all cabinet installation:

All Cabinet Installations

- Hammer
- Wire cutter
- Utility knife
- Screwdriver (flat blade)
- Torque wrench (with 7/16-inch socket and standard screwdriver socket)
- Tape measure
- Pen or marker
- 9/16-inch wrench
- 216B key tool (accessory - required to open cabinet door)
- 3/16-inch hex-key (required to open riser panels or remove lifting eyes)
- Level
- Padlock (optional)
- Grounding system, copper wire, and grounding clamp (per local requirements)
- Splicing equipment for splicing OSP feeder and distribution cables

- Tamping equipment
- Excavation and earth moving equipment
- Lifting equipment for hoisting the cabinet into position for mounting
- Landscaping equipment and site restoration supplies

Mounting Sleeve Installation

The following additional materials are required for mounting the cabinet on a mounting sleeve:

- Mounting Sleeve kit (FMS-ACE100-KIT-A)
- Stone aggregate
- Hole saw and drill (use to cut holes for cable conduit if pre-drilled holes are not usable)

Concrete Pad Installation

The following additional materials are required for mounting the cabinet on a concrete pad:

- Pad Mount Frame kit for FDH 3000 cabinet (FD3-PMFE06)
- Concrete finishing equipment
- Approximately 11.5 cu. ft. concrete
- Sand or gravel
- 2 x 6 inch framing lumber
- 1 x 4 inch wooden stakes (4)
- Nails and construction screws
- Utility wire (to secure PMF during installation)
- Saw
- Drill with screwdriver bits
- Square

2.6 Cabinet Mounting

The next two sections provide installation instructions for the various cabinet mounting systems. Use whichever procedure is appropriate for the installation.

3 MOUNTING THE CABINET ON A MOUNTING SLEEVE

The FMS, shown in [Figure 4](#), is a polymer concrete sleeve that may be used to support the cabinet at ground level. The FMS may also be used as a splicing vault. Four vertical racks are molded into the sides of the FMS to accommodate removable rungs (not provided). The rungs provide support for splice cases or OSP cable storage.

3.1 Installation Recommendations

The site chosen for the installation must conform to all local codes and any permits required must be obtained prior to the start of installation. The location must be accessible and provide adequate parking for worker and vehicle safety. Situate the FMS close to the trench that was used for routing the OSP fiber cables for the network distribution system.

The installed cabinet must not create a visual or physical obstruction to vehicular or pedestrian traffic. Ensure that there is sufficient space on all sides to facilitate cabinet installation. Depending on the landscaping requirements, the top surface of the mounting sleeve may be located from 0 to 4 inches (10.2 cm) above the surrounding grade.

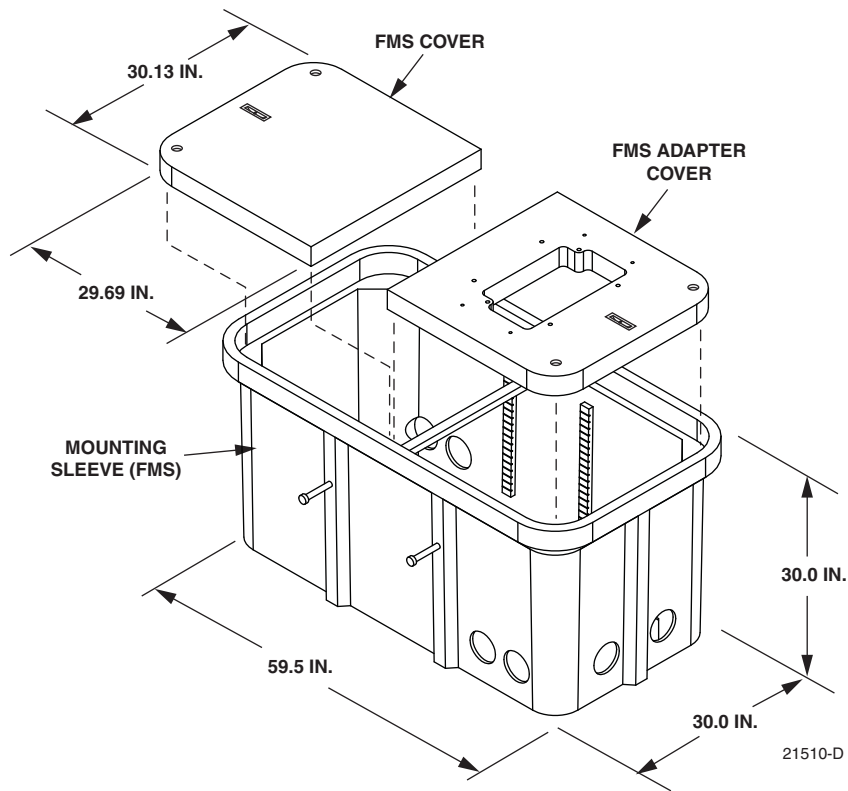

Figure 4. Mounting Sleeve (FMS-ACE100-KIT-A)

3.2 Excavation

The excavation must be large enough to provide a fill base that will maintain stability for the FMS and the cabinet mounted on it. There must be room for 12 inches (30.5 cm) of fill below and on each side of the FMS. The excavation dimensions for the FMS are shown in Figure 5. Excavate a rectangular hole for the FMS.

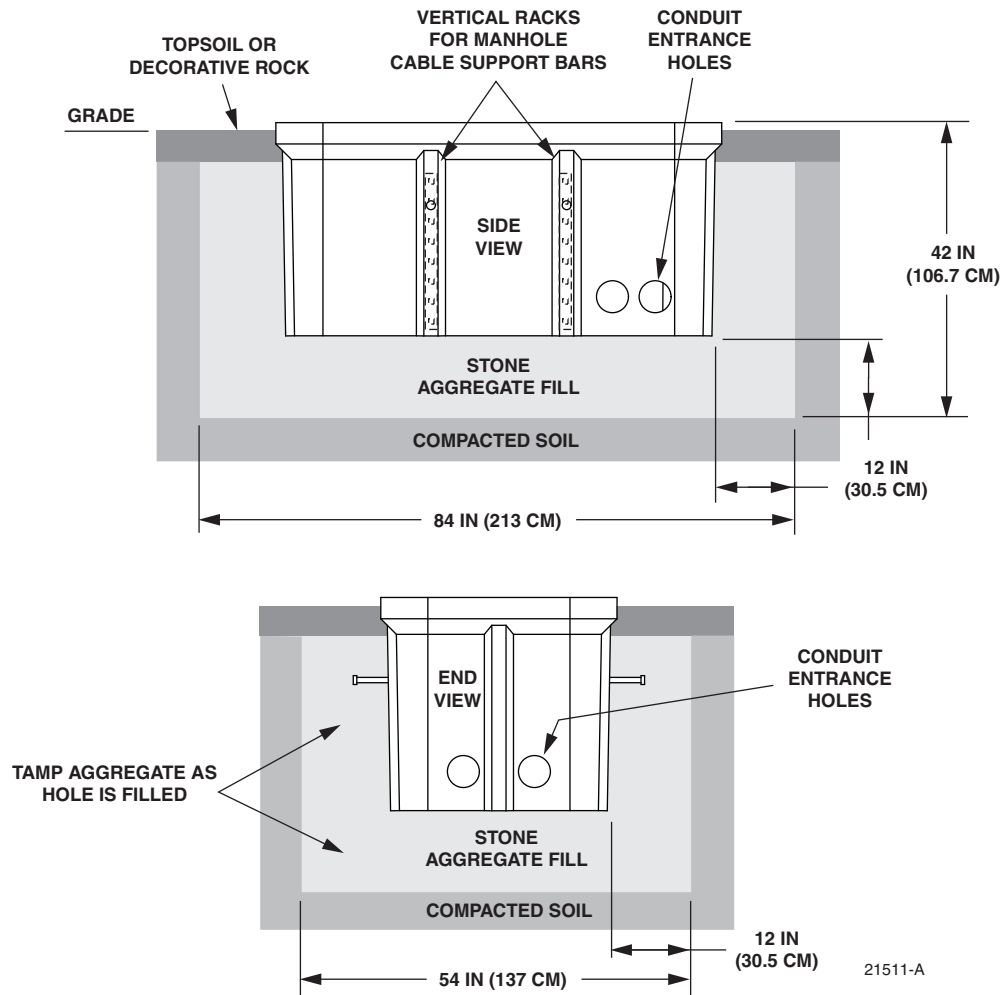

Figure 5. Excavation Recommendations for FMS-ACE100-KIT-A

3.3 Placement of the FMS



Danger: Use adequate lifting equipment when installing the FMS. Do not stand in the hole while placing the FMS in position. An unexpected shift of the FMS could result in personal injury.

Use the following procedures to place the FMS into the excavation.

1. Fill the bottom of the hole with stone aggregate, tamping it as it is filled to build a 12 inch (30.5 cm) layer with a level surface. The stone aggregate will provide a stable base to support the FMS.

► **Note:** Use crushed rock 3/8-inch or less in size mixed with stone dust (per local practice) to fill the hole. The name of the material may differ in different geographical areas. Possible names are Class 5, stone dust, aughts (0s) and ones (1s), or stone aggregate

2. Use appropriate lifting equipment to place the FMS into the center of the hole. Lifting loops are provided on either side of the FMS for attaching a sling or chain.
3. Use a carpenter's level to verify that the FMS is level. If it is necessary to add or remove fill for leveling, tamp any added fill to maintain the base stability.

3.4 Cable Conduit Installation

Select the conduit entrance holes (see [Figure 5](#)) for the OSP feeder and distribution cables. If necessary, additional conduit entrance holes may be cut using a power drill and hole saw. Place and route the conduit into the entrance hole(s). If preferred, the FMS may be installed without conduit. OSP cables may be routed into the FMS at any point that is convenient. Cut the cable entrance hole to match the size of the cable.

3.5 Grounding System Installation

Install a grounding system (not provided) that meets all local electrical codes. Check local codes for grounding system installation, use of clamps, wire size, and any other grounding requirements. Typically, #6 AWG copper wire is used for the grounding wire. Install the grounding system inside the FMS where it will not interfere with the conduit or cables. Leave sufficient slack in the grounding wire to allow it to be routed into the cabinet after the cabinet is mounted on the sleeve.

3.6 Back Fill

If installing conduit, hand shovel stone aggregate under the conduit to avoid damage from the power tamper. Complete the back fill as follows:

1. Add stone aggregate evenly around the FMS and tamp. Fill to approximately 6 inches (15.2 cm) from the top of the excavation.
2. Complete the back-fill with crushed rock or topsoil depending on the landscaping requirements. The top surface of the mounting sleeve may be located from 0 to 4 inches (10.2 cm) above the surrounding grade (see [Figure 5](#)).

3.7 Mounting the Cabinet on the FMS

Use the 216B key tool to un-latch and latch the cabinet door as needed during the mounting process. Refer to [Figure 6](#) as necessary when mounting the cabinet.



Warning: Use appropriate lifting equipment when moving or installing the cabinet. Do not stand under a cabinet as it is being hoisted into position for mounting. A failure of the lifting equipment could result in serious personal injury.

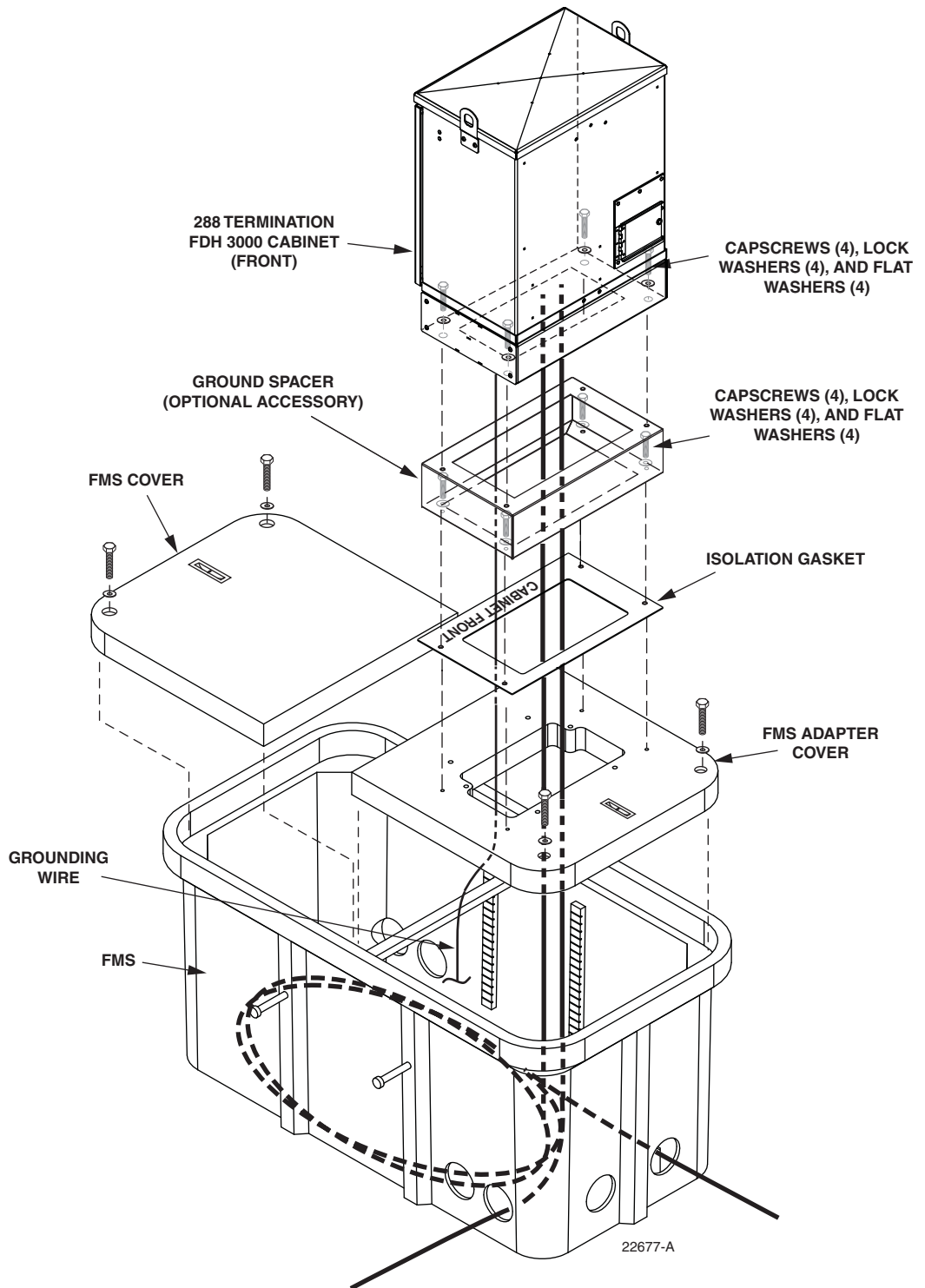

Figure 6. Mounting the 288 Termination Cabinet With Splicing on the FMS

Use the following procedure to mount the cabinet on the FMS:

1. Use a 3/16-inch hex-key to remove the screws that secure the access covers to the left and right sides of the cabinet ground spacer/riser as shown in Figure 7.

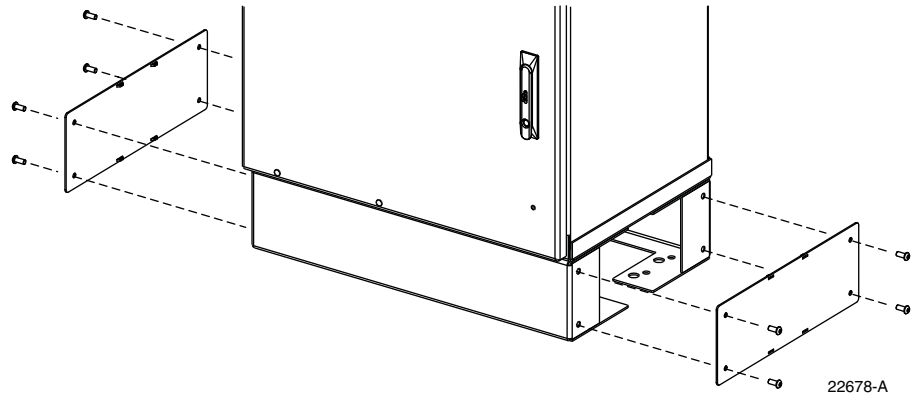

Figure 7. Removing Side Access Covers From Ground Spacer/Riser

2. Remove the access covers from the ground spacer/riser and set aside both the covers and the screws for reuse.
3. Mount the FMS adapter cover on the FMS and secure using the two capscrews and flat washers provided. Tighten each capscrew securely.
4. Place the isolation gasket (provided with cabinet) on the adapter cover and align the holes in the gasket with the holes in the adapter cover. Make sure the wide side of the gasket is on the side of the adapter cover that corresponds to the front side of the cabinet.
5. If a ground spacer/riser (optional accessory) will be installed, place the spacer in position for mounting on the adapter cover. The isolation gasket installed in step 4 should remain in place between the adapter cover and ground spacer. If a ground spacer will not be installed, proceed to step 8.
6. Align the mounting holes in the spacer/riser with the mounting holes in the adapter cover.
7. Secure the spacer/riser to the adapter cover using the four capscrews, four lock washers, and four flat washers provided with the spacer. Tighten all capscrews securely.
8. Using appropriate lifting equipment, hoist the cabinet into position for mounting on the spacer/riser or adapter cover.



Danger: Do not stand directly under the cabinet as it is being hoisted into position for cable installation. A failure of the lifting equipment could result in serious personal injury.

9. Lower the cabinet onto the ground spacer/riser or adapter cover and align the mounting holes in the cabinet base with the threaded holes in the spacer/riser or adapter cover. If a spacer/riser was not installed, leave the isolation gasket (installed in step 4) in place on the adapter cover.
10. Secure the cabinet to the spacer/riser or adapter cover using the four capscrews, lock washers, and flat washers provided with the cabinet. Tighten all four capscrews securely.
11. Install the FMS sleeve cover on the FMS and secure using the two capscrews and washers provided. Tighten both capscrews securely.

- ▶ **Note:** The FMS sleeve cover may be installed at a later time so the interior of the FMS sleeve to be accessed for cable installation, ground wire installation, or splicing.
- 12. The lifting eyes may be left in place or removed from the cabinet. To remove the lifting eyes, use the 3/16 hex-key to remove the lifting eye screws. Store the lifting eyes inside the cabinet and then re-install the lifting eye screws in the cabinet.

3.8 Grounding Wire Connection To Cabinet

Prior to mounting the cabinet, a grounding system and grounding wire should have been installed (see [Section 3.5](#)) in the space below the cabinet. Use the following procedure to connect the grounding wire to the cabinet:

1. Locate the grounding wire that was installed inside the FMS prior to mounting the cabinet.
2. Working from the bottom side of the cabinet, insert the grounding wire through the flexible membrane at the point indicated in [Figure 8](#).

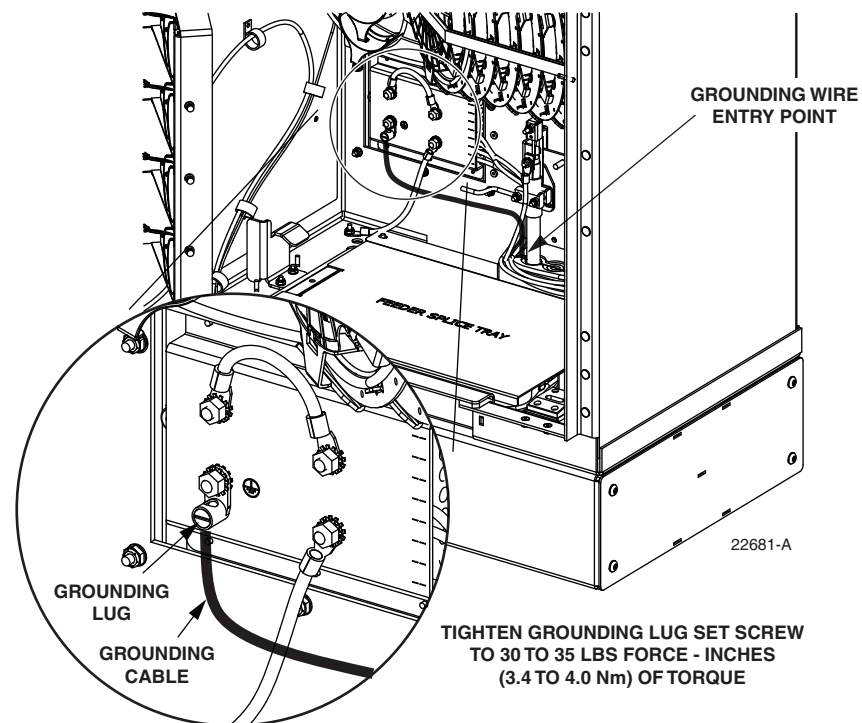

Figure 8. Grounding Wire Connection To Cabinet

3. Attach the grounding wire to the cabinet grounding lug. The grounding lug can be used for #6 to #14 AWG wire.
4. Tighten the grounding lug set screw to 30 to 35 lbs force-inches (3.4 to 4.0 Nm) of torque.
5. Reinstall the left and right access covers that were removed in step 1 of [Section 3.7](#). Use the 3/16-inch hex-key to tighten the screws that secure the access covers to the sides of the cabinet ground spacer/riser.

4 MOUNTING THE CABINET ON A CONCRETE PAD

The Pad Mount Frame (PMF), shown in [Figure 9](#), is a stainless steel frame that provides a mounting base for the cabinet when embedded in a concrete foundation.



Caution: *Mounting the cabinet directly on a concrete pad may cause chemical corrosive action to the cabinet. Use only the Pad Mount Frame (PMF) as a mounting base for the cabinet. Do not use caulking compounds as a sealer between the cabinet and the PMF.*

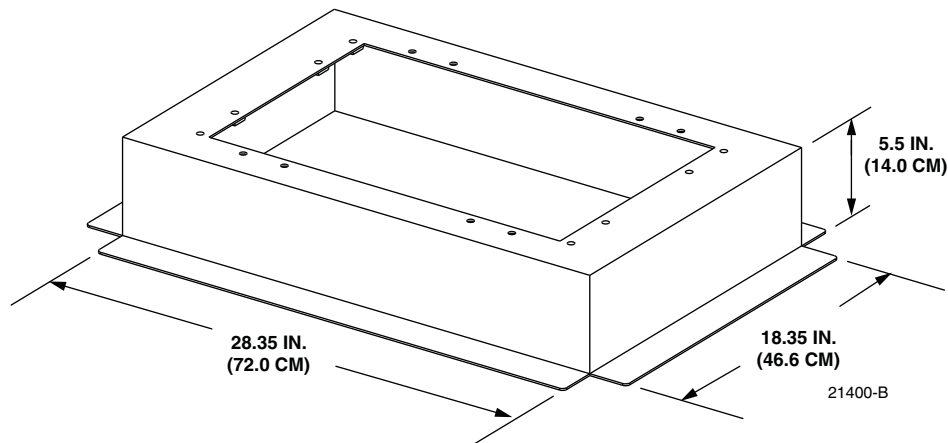

Figure 9. Pad Mount Frame Dimensions

4.1 Installation Recommendations

The site chosen for the installation must conform to all local codes and any permits required must be obtained prior to the start of installation. The location must be accessible and provide adequate parking for worker and vehicle safety. Situate the concrete pad close to the trench that was used for routing the OSP fiber cables for the network distribution system.

The installed cabinet must not create a visual or physical obstruction to vehicular or pedestrian traffic. Ensure that there is sufficient space on all sides to facilitate cabinet installation. Depending on the landscaping requirements, the top surface of the concrete pad may be located from 0 to 3 inches (7.6 cm) above the surrounding grade.

4.2 Base Construction and Conduit Installation

Prepare a base for the concrete pad that meets all local code requirements. The base must have a footing of 4 to 6 inches (10.2 to 15.2 cm) of sand or gravel (per local practice) on firmly compacted soil. Refer to the construction diagram in [Figure 10](#) for details.

Install the cable conduit from below and position it so that the top of each upward bend will be located within the PMF opening at the indicated point. When installed, the top of the conduit should be located 1 to 2 inches (2.54 to 5.08 cm) **below** the top of the finished concrete pad. Install the conduit **before** pouring the pad.

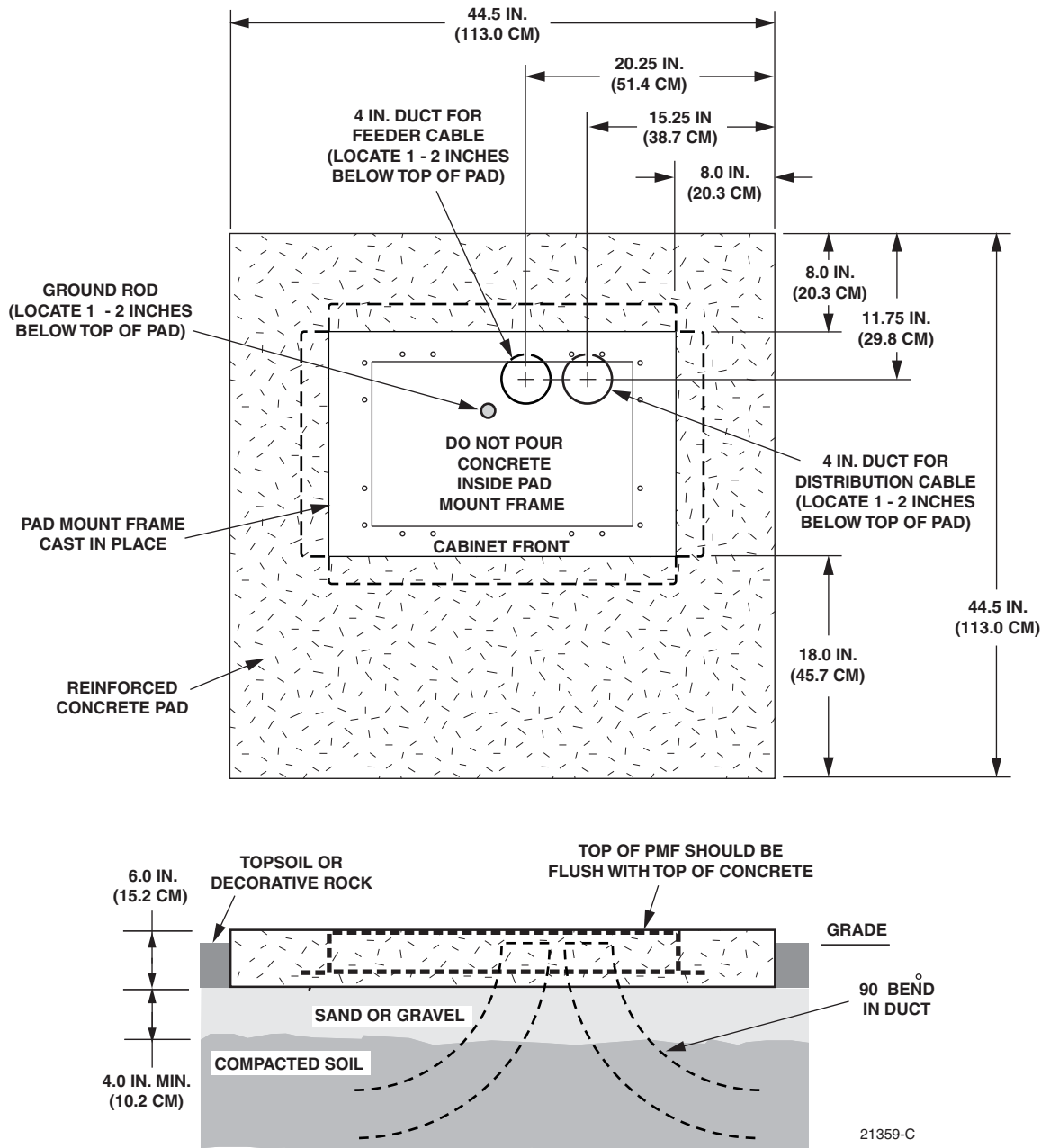

Figure 10. Constructing the Concrete Pad for the 288 Termination Cabinet With Splicing

A template is provided with the cabinet isolation gasket. The template may be used to determine the cable conduit locations. Place the template over the top of the PMF and align the top right corner of the template with the top right corner of the PMF as shown in [Figure 11](#). The holes punched in the template show the locations for the conduit within the PMF.

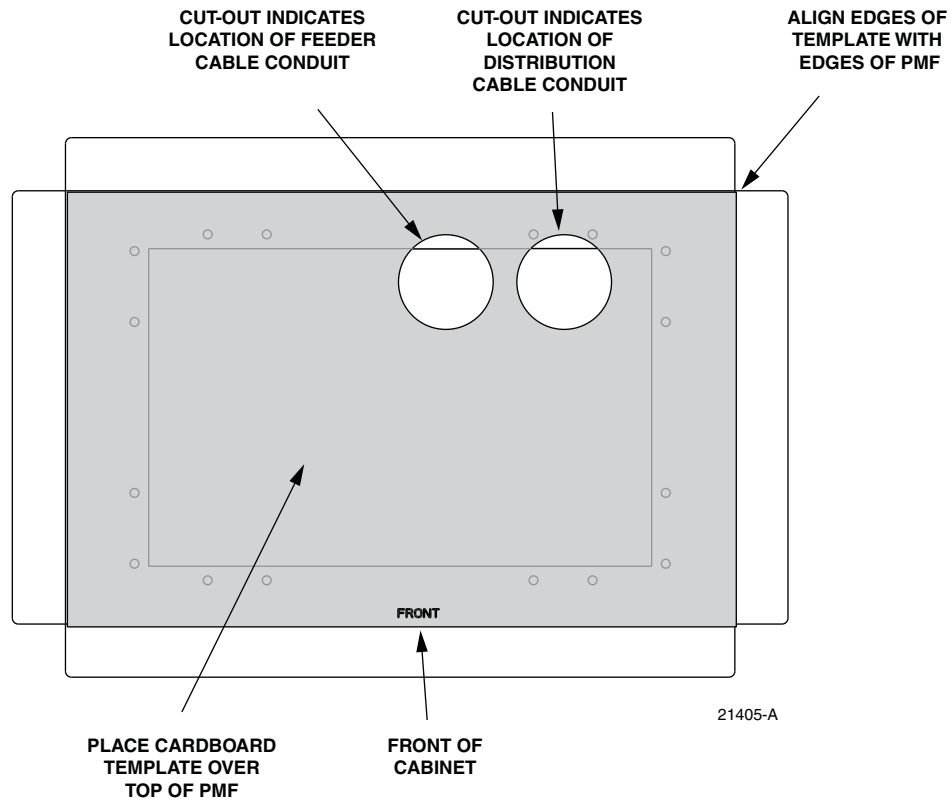

Figure 11. Using the Template To Determine Duct Location Within the PMF

4.3 Concrete Pad Construction

Use the following procedure to construct the concrete pad:

1. Build a wood form for the concrete pad using 2 x 6 framing lumber as shown in [Figure 12](#).
 2. Locate the PMF as shown in the construction diagram (see [Figure 10](#)). When installed, the top surface of the PMF must be flush and level with the top of the concrete pad.
- **Note:** Use temporary top framing to keep the top surface of the PMF flush and level with the top of the concrete pad (see [Figure 12](#)).
3. Place reinforcing material inside the form but outside of the PMF.
 4. Verify that the PMF and form are level. Depending on the landscaping requirements, the top surface of the concrete pad may be 0 to 3 inches (0 to 7.6 cm) above the final grade. The weld nuts are covered with plugs which must be left in place until the enclosure is mounted.
 5. Pour the concrete to form the pad but do *not* pour concrete into the center area of the PMF.
- **Note:** Allow some concrete to flow under the flanges on the bottom of the PMF so the PMF will be locked in place when the concrete hardens. However, do not allow concrete to fill the center of the PMF. If necessary, partially fill the center of the PMF with sand or gravel to prevent an inflow of concrete.

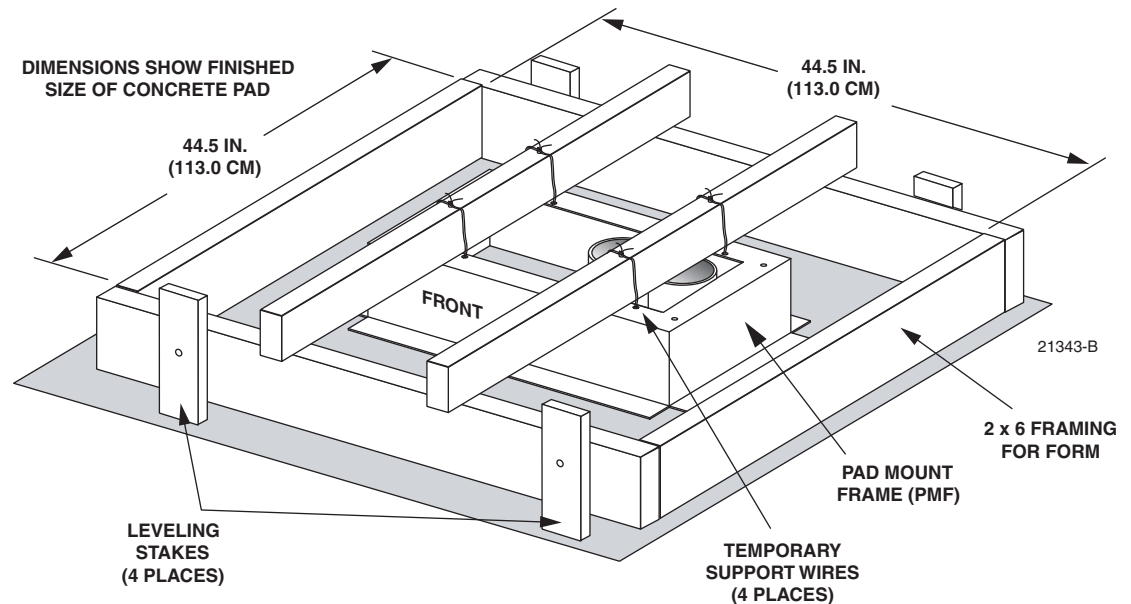

Figure 12. Concrete Pad Framing

6. Remove the top framing and the temporary support wires when the concrete is ready to be finished.
7. Allow concrete to cure before proceeding with the installation.

4.4 Grounding System Installation

Install a grounding system (not provided) that meets all local electrical codes. Check local codes for grounding system installation, use of clamps, wire size, and any other grounding requirements. Typically, #6 AWG copper wire is used for the ground wire. If the grounding system includes a ground rod, install the rod (see [Figure 10](#)) within the PMF opening at the indicated point. When installed, the top of the rod should be located 1 to 2 inches (2.54 to 5.08 cm) **below** the top of the finished concrete pad. Leave sufficient slack in the grounding wire to allow it to be routed into the cabinet after the cabinet is mounted on the pad.

4.5 Mounting the Cabinet on the Concrete Pad

Use the 216B key tool to un-latch and latch the cabinet doors as needed during the mounting process. Refer to [Figure 13](#) as necessary when mounting the cabinet.



Warning: Use appropriate lifting equipment when moving or installing the cabinet. Do not stand under the cabinet as it is being hoisted into position for installation. A failure of the lifting equipment could result in serious personal injury.

Use the following procedures to mount the cabinet on the concrete pad.

1. Use a 3/16-inch hex-key to remove the screws that secure the access covers to the left and right sides of the cabinet ground spacer/riser as shown in Figure 14.

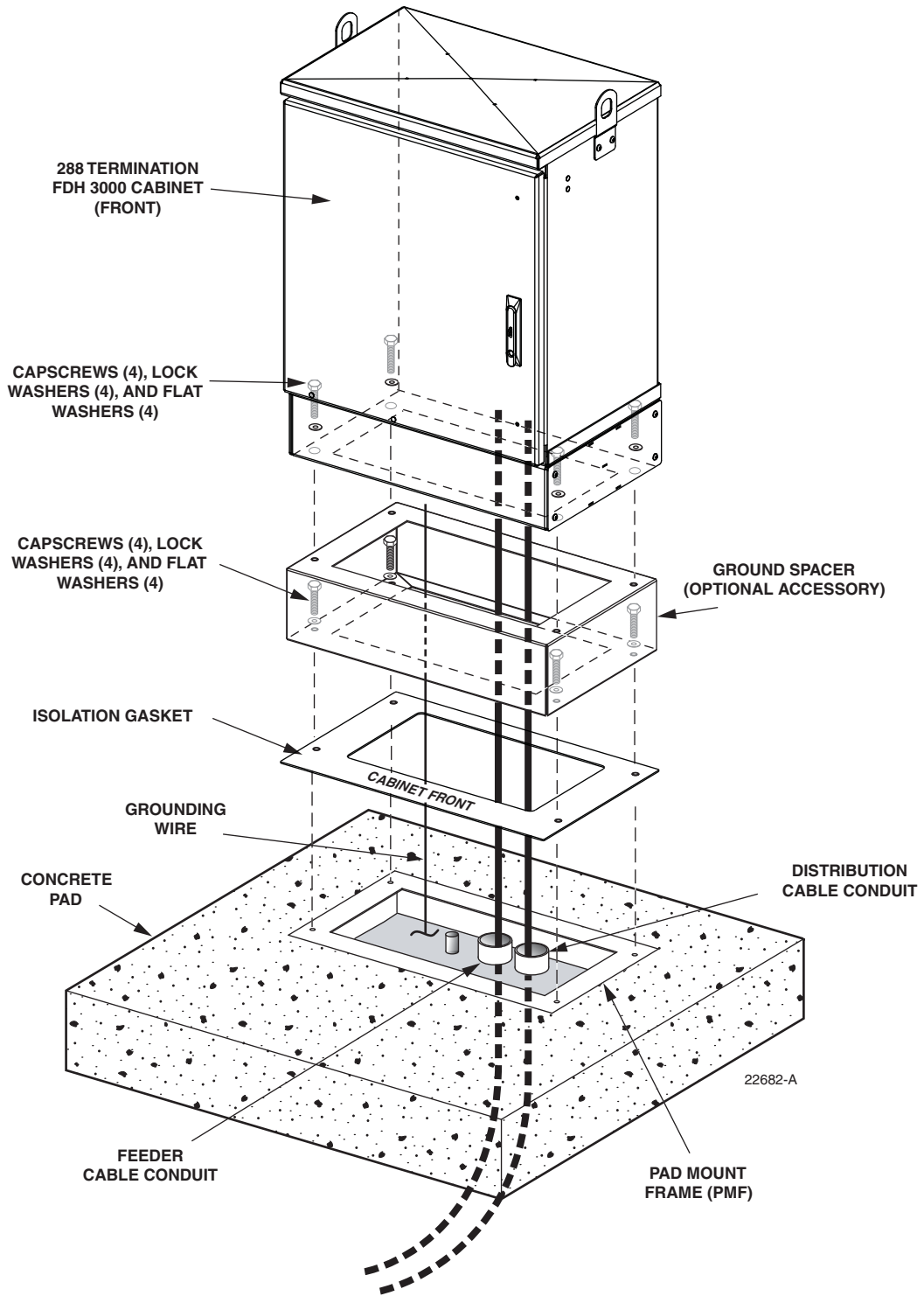

Figure 13. Mounting the 288 Termination Cabinet with Splicing on the Concrete Pad

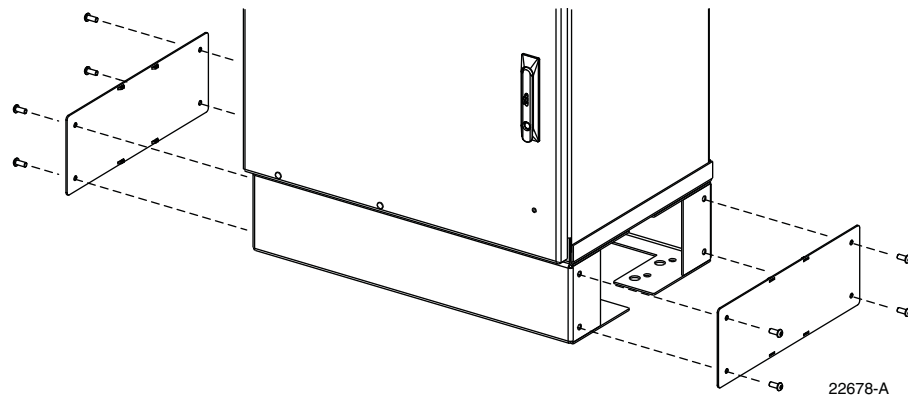

Figure 14. Removing Side Access Covers From Ground Spacer/Riser

2. Remove the plastic plugs that are installed in the threaded corner holes of the PMF and clean off any concrete that may have adhered to the top of the PMF.
- **Note:** Make sure all remnants of concrete are removed from the PMF prior to mounting the cabinet. It is not necessary to use shims to level or align the cabinet as long as the top surface of the PMF is clean and free of any installation debris.
3. Place the isolation gasket (provided with cabinet) on the PMF and align the holes in the gasket with the holes in the PMF. Make sure the wide side of the gasket is on the side of the PMF that corresponds to the front side of the cabinet.
4. If a ground spacer/riser (accessory) will be installed, place the spacer/riser in position for mounting on the PMF. The isolation gasket installed in step 3 should remain in place between the PMF and spacer/riser. If a spacer/riser will not be installed, proceed to step 7.
5. Align the mounting holes in the spacer/riser with the mounting holes in the PMF.
6. Secure the spacer/riser to the PMF using the four capscrews, four lock washers, and four flat washers provided. Tighten all capscrews securely.
7. Using appropriate lifting equipment, hoist the cabinet into position for mounting on the spacer/riser or PMF.



Danger: Do not stand directly under the cabinet as it is being hoisted into position for cable installation. A failure of the lifting equipment could result in serious personal injury.

8. Lower the cabinet onto the ground spacer/riser or PMF and align the mounting holes in the cabinet base with the threaded holes in the spacer/riser or PMF. If a spacer/riser was not installed, leave the isolation gasket (installed in step 3) in place on the PMF.
9. Secure the cabinet to the spacer/riser or PMF using the four capscrews, four lock washers, and four flat washers provided with the cabinet. Tighten all four capscrews securely.
10. The lifting eyes may be left in place or removed from the cabinet. To remove the lifting eyes, use the 3/16 hex-key (accessory) to remove the lifting eye screws. Store the lifting eyes inside the cabinet and then re-install the lifting eye screws in the cabinet.

4.6 Grounding Wire Connection To Cabinet

Prior to mounting the cabinet, a grounding system and grounding wire should have been installed (see [Section 4.4](#)) in the space below the cabinet. Use the following procedure to connect the grounding wire to the cabinet:

1. Locate the grounding wire that was installed prior to mounting the cabinet on the pad.
2. Working through the access openings in the base of the cabinet, insert the grounding wire through the flexible membrane at the point indicated in [Figure 15](#).
3. Attach the grounding wire to the cabinet grounding lug. The grounding lug can be used for #6 – #14 AWG wire.
4. Tighten the grounding lug set screw 30 to 35 lbs force-inches (3.4 to 4.0 Nm) of torque.
5. Reinstall the left and right access covers that were removed in step 1 of [Section 4.5](#). Use the 3/16-inch hex-key to tighten the four screws that secure each access cover to the sides of the cabinet ground spacer/riser.

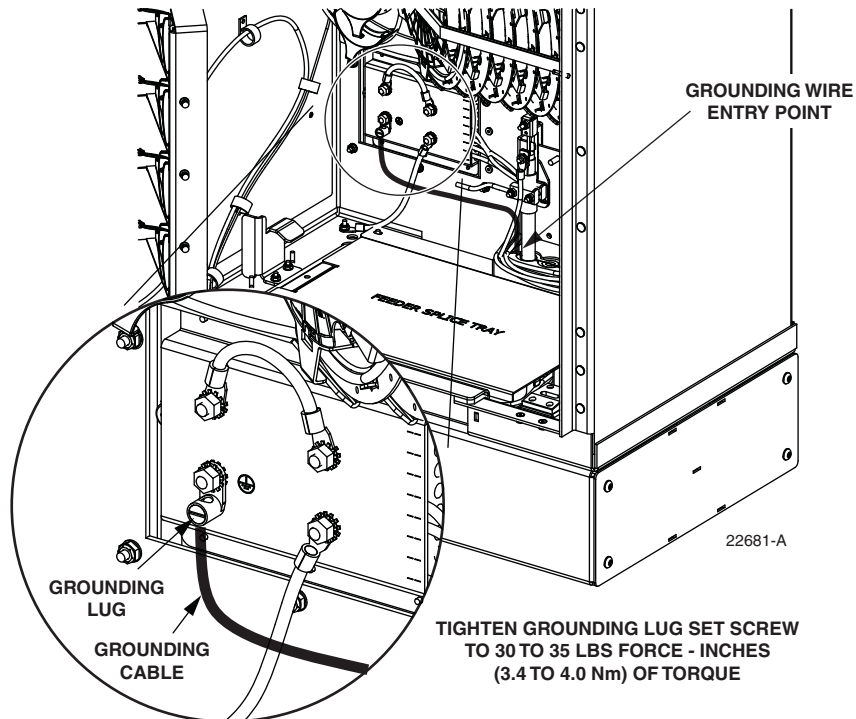

Figure 15. Grounding Wire Connection To Cabinet

5 FEEDER CABLE INSTALLATION AND SPLICING

This section describes how to install the OSP feeder cable and how to splice the feeder cable fibers to the splitter input fibers.

5.1 Cable Bracket Cover Removal/Installation

The cabinet is equipped with a cable bracket cover that prevents dirt, moisture, and insects from entering the cabinet through the cable entry/exit holes. The cable bracket cover must be removed to allow installation of the OSP cables and then reinstalled when the cables are in place. Use the following procedure to remove/install the cable bracket cover:

1. Remove the five nuts and flat washers that secure the cable bracket cover to the bottom of the cabinet as shown in [Figure 16](#). Save all nuts and washers for later re-installation.
2. Lift the cable bracket cover upward until it is free of the mounting studs and then set it aside for later re-installation.
3. Reinstall cover when installation of the feeder and distribution cables is complete.

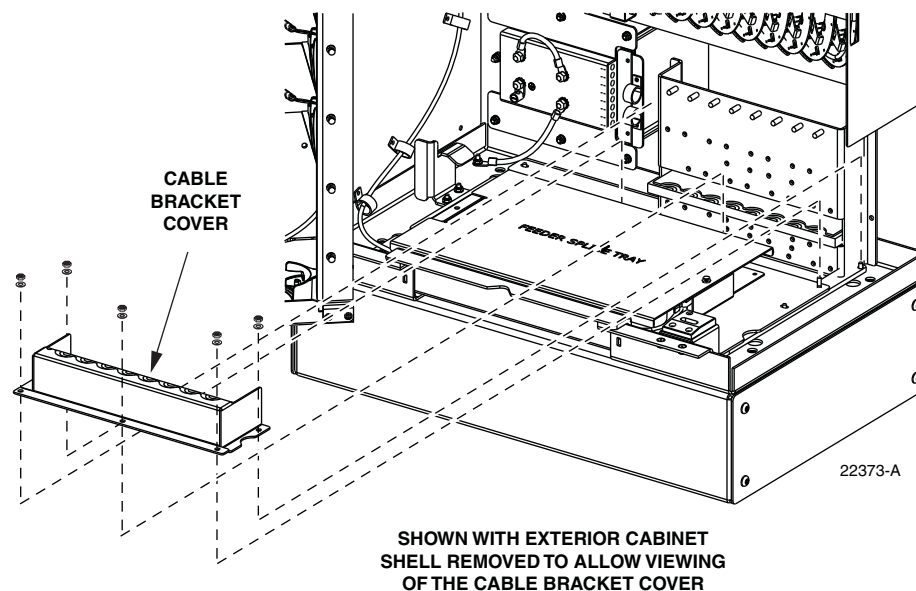

Figure 16. Cable Bracket Cover Removal/Installation

5.2 Feeder Cable Installation

The OSP feeder cable enters/exits the cabinet from the bottom. At the entry/exit point to the cabinet, the feeder cable is secured with two clamps. Beyond the clamps, the outer sheath of the cable is removed to expose the optical fibers. The feeder cable is typically a 12-, 24-, or 48-fiber cable with stranded fiber construction. Blocking and/or grounding kits should be installed (per local practice) to protect the exposed optical fibers. From the clamping point, the optical fibers are routed to splice trays for splicing to the splitter input fibers. A lug for securing cable strength members is provided with the cabinet.

Use the following procedure to install the feeder cable:

1. Remove the cable bracket cover (if not already removed) from the cabinet as described in [Section 5.2](#) to allow installation of the OSP cables. Then return to step 2 of this procedure to complete installation of the feeder cable.

2. Route the feeder cable into the cabinet from the bottom. If the cabinet is mounted on a concrete pad, use the duct on the **left** side.
 3. Pull the cable up through the cabinet and strip off **17.5 feet (5.4 m)** of the outside cable sheath to expose the fiber subunits.
 4. Install breakout/blocking and grounding kits as required by local practice. Follow the installation instructions provided with each kit.
- **Note:** If a grounding kit is required, strip the cable sheath to the recommended length and install the grounding clamp prior to securing the cable to the cabinet.
5. Locate the cable clamping position specified for securing the feeder cable to the cable bracket as shown in [Figure 17](#).

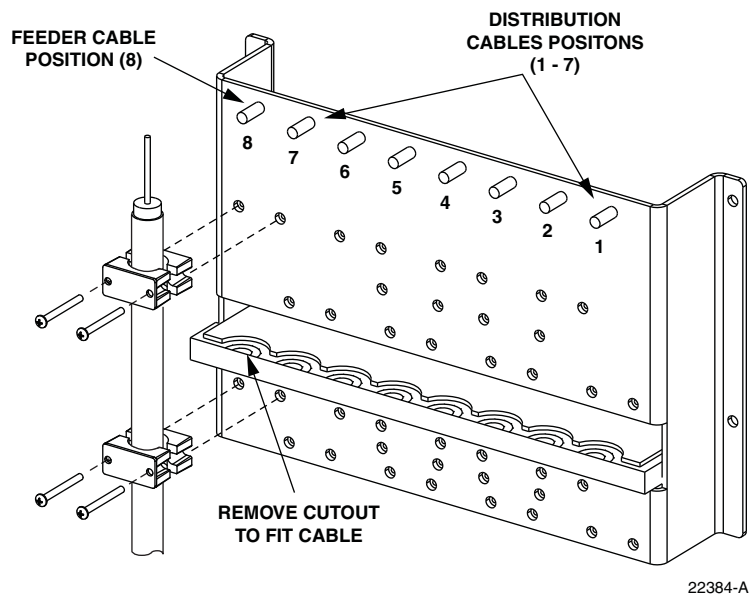

Figure 17. Secure Feeder Cable to Cable Bracket

6. Locate the clamps, grommets, cover plates, and screws that are provided for securing the cable to the cabinet.
- **Note:** Two small cable clamps are provided for securing the feeder cable to the cabinet.
7. Assemble each pair of clamps (and grommet if required) on the cable as shown in [Figure 18](#) and secure the cable to the cabinet at the feeder cable clamping position.
- **Note:** Rubber plugs are inserted into the cable bracket holes to prevent insects from entering the cabinet. Remove only those rubber plugs necessary to allow installation of the feeder cable clamps. All other plugs should be left in place.
8. If the cable has a central strength member, locate the lug that is provided for clamping the strength member to the cable bracket. If the cable does not have a central strength member, proceed to step 11.

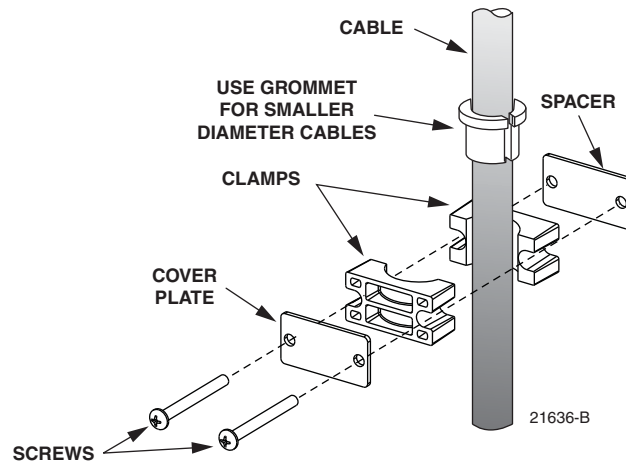

Figure 18. Cable Clamp Assembly

9. Insert the central strength member into the lug as shown in [Figure 19](#) and then install the lug on the cable bracket.

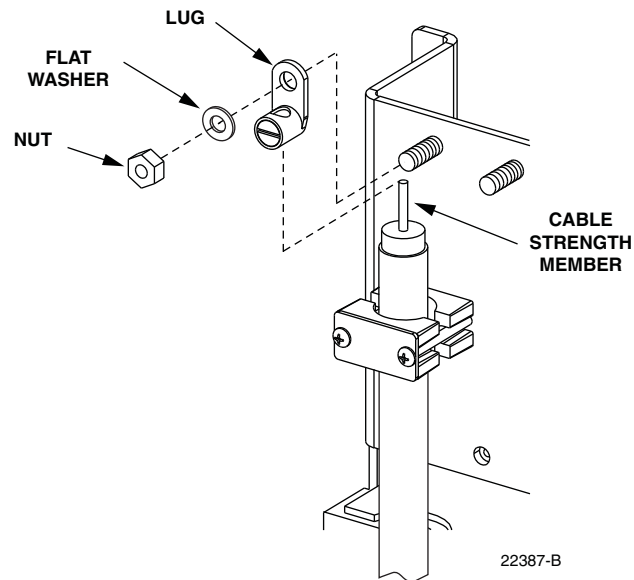

Figure 19. Strength Member Lug Installation

10. Trim the central strength member to length and tighten the lug set screw.
11. If a grounding kit was installed on the cable, refer to [Section 5.3](#) for the cable grounding procedure. If a grounding kit was not installed on the cable, refer to [Section 5.4](#) for the feeder cable splicing procedure.

5.3 Grounding the Feeder Cable

If the feeder cable is constructed with a metallic shield or other metallic components, a grounding kit must be installed on the cable. Use the following procedure for grounding a feeder cable that has been fitted with a grounding kit:

1. Connect a #6 AWG stranded copper jumper wire (terminated with ring terminals) to the feeder cable grounding stud.
2. Locate the weather-seal strip attached to the right side of the cabinet grounding system as shown in [Figure 20](#).

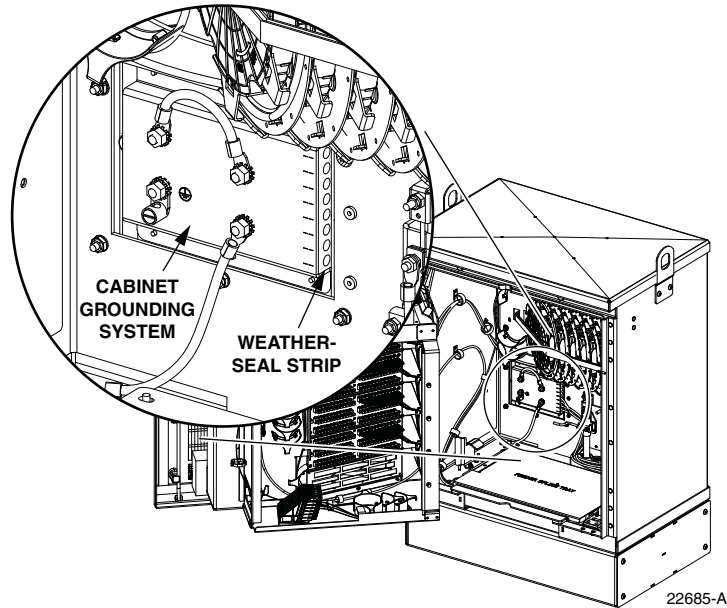

Figure 20. Cable Grounding System - Interior View

3. Route the feeder cable jumper wire to the weather-seal strip as shown in [Figure 21](#) and push the free end of the wire through the hole that corresponds to cable 8.
- ▶ **Note:** The fiber optic cables are numbered 1 – 8 starting with the first cable on the right side of the cable bracket. The holes for the grounding cables are numbered 1 – 8 starting with the top opening in the weather-seal strip.
4. Open the grounding system access cover located on rear of cabinet ([Figure 22](#)).
 5. Identify the grounding stud for cable #8.
- ▶ **Note:** A label on the back of the access cover indicates the grounding stud numbers.
6. Connect the grounding jumper wire to grounding stud #8.
- ▶ **Note:** Each grounding stud on the **left** bus bar is equipped with two nuts. When connecting a jumper wire to the **left** bus bar, place the cable terminal **between** the two nuts.
7. Tighten the grounding stud nut to 30 to 35 lbs force-inches. (3.4 to 4.0 Nm) of torque.

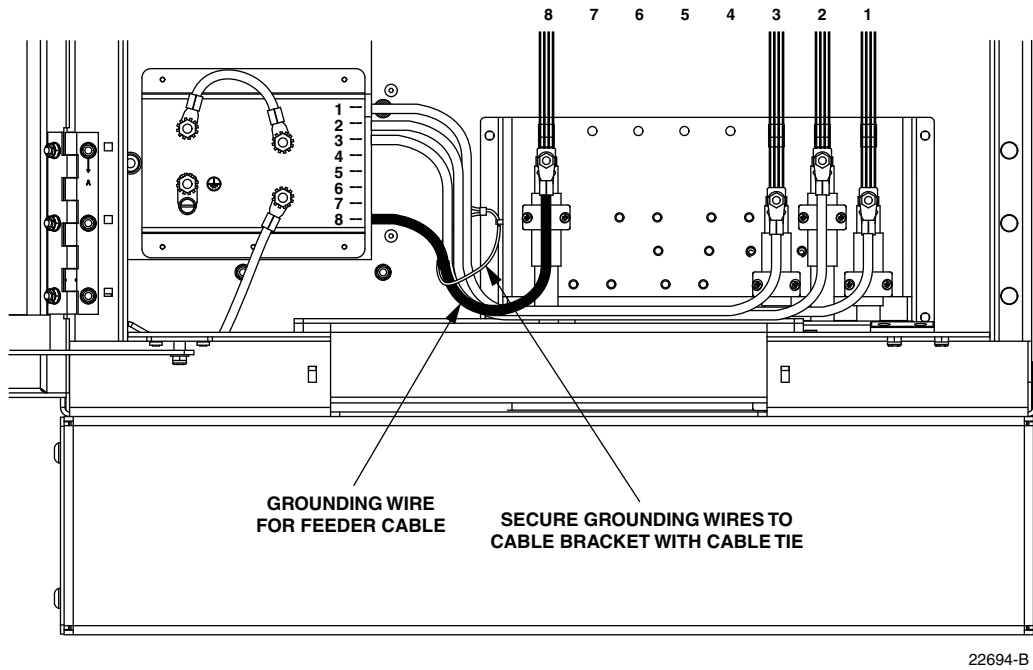

Figure 21. Route Grounding Cable to Grounding System



Warning: The grounding cables are connected to cabinet ground through the copper grounding blocks. Failure to properly tighten the nut on each individual cable grounding stud could result in improper grounding of the cable and result in performance or safety issues.

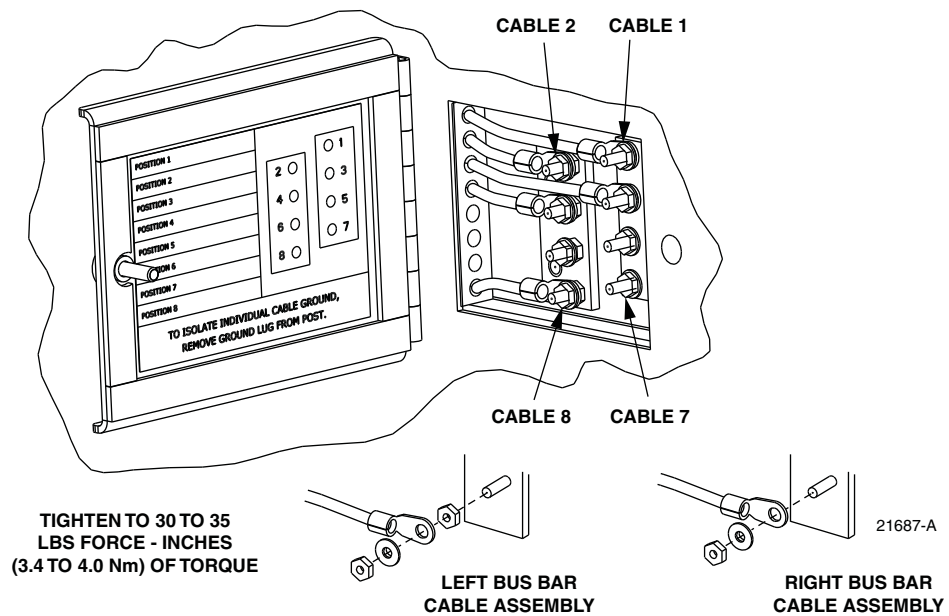

Figure 22. Cable Grounding System - Exterior View

8. Close the cable grounding system access door and secure using the 216B tool.

5.4 Splicing the Feeder Cable Fibers

Depending on the option ordered, the cabinet may be equipped with either one or two splice trays for feeder cable splicing. Use the following procedure to route the feeder cable fibers to the splice trays and to splice the feeder cable fibers to the splitter input fibers:

1. Locate the feeder splice tray which is mounted at the bottom of the cabinet, as shown in [Figure 23](#), and locate the splitter input fibers which are routed to the feeder splice tray.

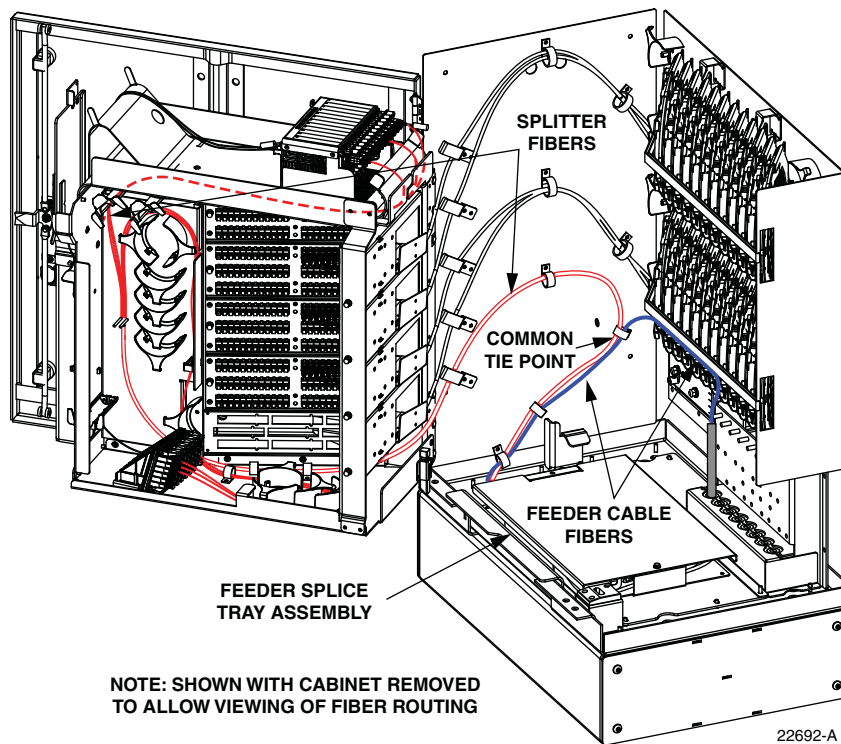

Figure 23. Feeder Splice Tray and Feeder/Splitter Fiber Routing

2. Lift the sheet metal cover away from the splice tray holder as shown in [Figure 24](#).
3. Unfasten the hook and pile strips that secure the tray in place and unwind the attached splitter fibers from around the splice tray assembly.
4. Beginning at the feeder cable subunit breakout point shown in [Figure 25](#), route the feeder cable fibers to the intersect point with the splitter fibers.



Caution: Always allow sufficient fiber length to permit routing without severe bends. Non bend-optimized fibers may be permanently damaged if bent/curved to a radius of less than 1.5 inches (3.81 cm).

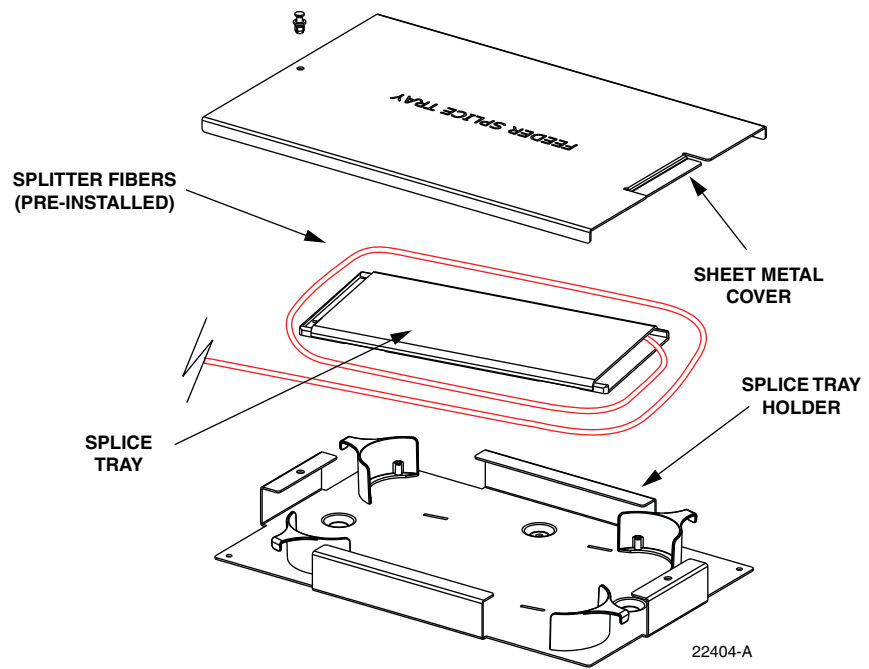

Figure 24. Feeder Splice Tray Assembly

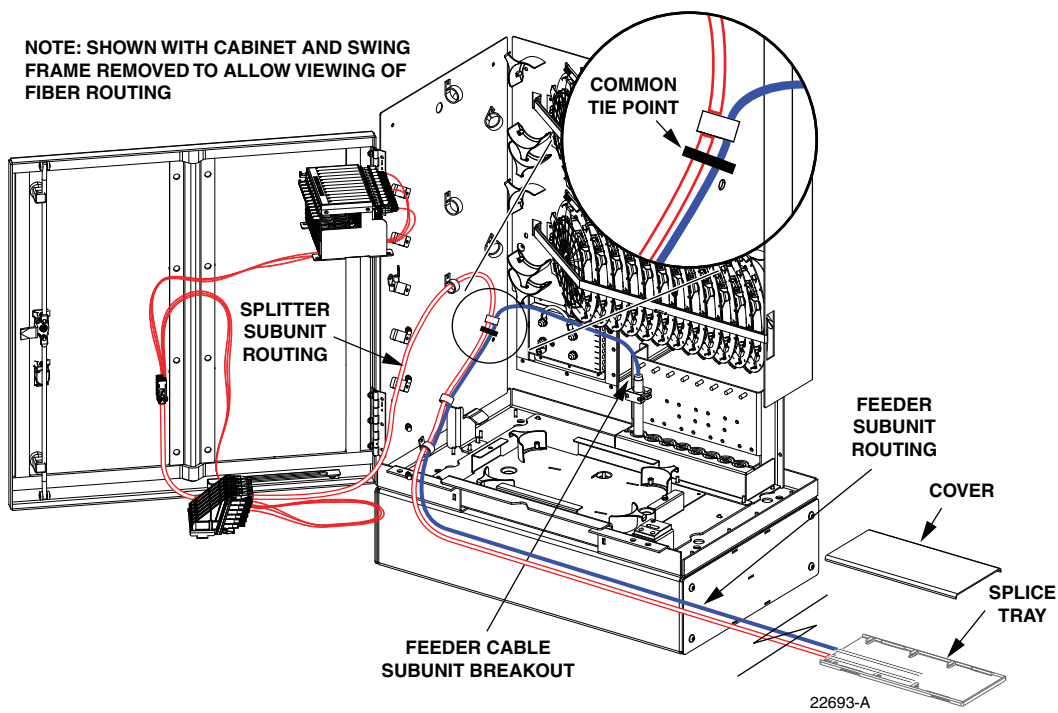

Figure 25. Feeder Fiber Routing To Splice Tray

5. Create a common tie point by securing the feeder cable subunits (use lacing or cable ties) to the splitter subunits at the intersect point.
6. Route the feeder cable subunits to the splice tray and then remove the clear plastic cover from the splice tray.
7. Use lacing or cable ties to secure the feeder cable subunits to the splice tray and verify that the feeder subunits are the same length as the attached splitter subunits. Adjust as needed to make the lengths equal.



Caution: *Improper handling can damage fiber optic cables. Do not over tighten cable ties or lacing as this can cause damage or attenuation. Do not compress the fibers or allow them to kink.*

8. From the tie point on the splice tray, trim the **feeder cable fibers** to a cut length of 28 inches (71 cm) and the **splitter fibers** to a cut length of 36 inches (92 cm).
9. Within the splice tray, remove the subunit tubes from the feeder cable fibers to expose the bare individual optical fibers.
10. Splice the feeder cable fibers to the appropriate splitter fibers as specified by local policies and procedures. Adjust and route the fibers within the splice tray as shown in [Figure 26](#). Refer to [Table 3](#) for the splitter fiber designations.
11. After splicing is completed, re-install the clear plastic cover on the splice tray.

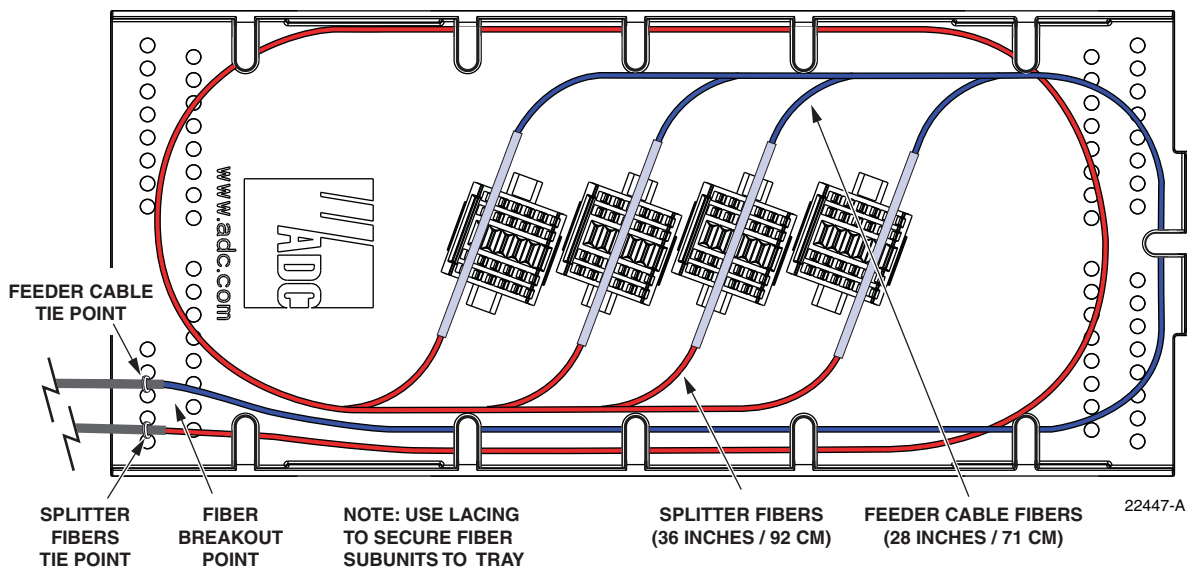

Figure 26. Stranded Fiber Splice Tray - Feeder Cable Splicing

12. To replace the splice tray, route the attached subunits (there should be two service loops) around the splice tray holder radius limiters as shown in [Figure 27](#). Avoid twisting or kinking the fiber subunit tubes. Maintain a 1.5-inch (3.81 cm) minimum bend radius for all non bend-optimized fiber.
13. Secure the splice tray to the splice tray holder using the hook and pile strips.
14. Re-install the sheet metal cover on the splice tray holder.

Table 3. Splitter and Spare Fiber Port Designations for 12-, 24-, and 48-Fiber Feeder Cables

SUBUNIT	FIBER	SPLITTER PORT	SPARE PORT	SUBUNIT	FIBER	SPLITTER PORT	SPARE PORT
1 (12-, 24-, or 48-fiber cable)	1 (Blue)	1	–	3 (48-fiber cable)	1 (Blue)	–	25
	2 (Orange)	2	–		2 (Orange)	–	26
	3 (Green)	3	–		3 (Green)	–	27
	4 (Brown)	4	–		4 (Brown)	–	28
	5 (Slate)	5	–		5 (Slate)	–	29
	6 (White)	6	–		6 (White)	–	30
	7 (Red)	7	–		7 (Red)	–	31
	8 (Black)	8	–		8 (Black)	–	32
	9 (Yellow)	9	–		9 (Yellow)	–	33
	10 (Violet)	10	–		10 (Violet)	–	34
	11 (Rose)	11	–		11 (Rose)	–	35
	12 (Aqua)	12	–		12 (Aqua)	–	36
2 (24- or 48-fiber cable)	1 (Blue)	13	–	4 (48-fiber cable)	1 (Blue)	–	37
	2 (Orange)	14	–		2 (Orange)	–	38
	3 (Green)	15	–		3 (Green)	–	39
	4 (Brown)	16	–		4 (Brown)	–	40
	5 (Slate)	17	–		5 (Slate)	–	41
	6 (White)	18	–		6 (White)	–	42
	7 (Red)	19	–		7 (Red)	–	43
	8 (Black)	20	–		8 (Black)	–	44
	9 (Yellow)	21	–		9 (Yellow)	–	45
	10 (Violet)	22	–		10 (Violet)	–	46
	11 (Rose)	–	23		11 (Rose)	–	47
	12 (Aqua)	–	24		12 (Aqua)	–	48

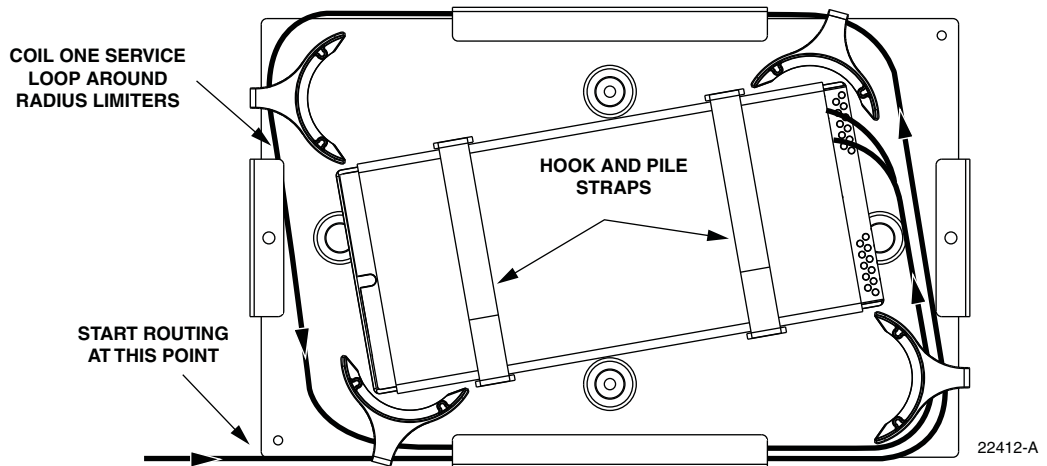

Figure 27. Feeder Splice Tray Replacement

6 DISTRIBUTION CABLE INSTALLATION AND SPLICING

This section describes how to install the OSP distribution cables and how to splice the distribution cable fibers to the distribution panel pigtails.

6.1 Distribution Cable Installation

The OSP distribution cables enter/exit the cabinet from the bottom. At the entry/exit point to the cabinet, the each cable is secured with two clamps. Beyond the clamps, the outer sheath of the cable is removed to expose the optical fibers. Distribution cables are typically 72- or 144-fiber cable with stranded construction. Blocking and/or grounding kits should be installed (per local practice) to protect the exposed optical fibers. From the clamping point, the optical fibers are routed to the splice trays for splicing to the distribution panel pigtails. A lug for securing cable strength members is provided with the cabinet

Use the following procedure to install each distribution cable:

1. Remove the cable bracket cover (if not already removed) from the cabinet as described in [Section 5.2](#) to allow installation of the OSP cables. Then return to step 2 of this procedure to complete installation of the distribution cable.
2. Route the distribution cable into the cabinet from the bottom. If the cabinet is mounted on a concrete pad, use the duct on the **right** side.
3. Pull the cable up through the cabinet and strip off **17 feet** (6.1 m) of the outside cable sheath to expose the fiber subunits.
4. Install breakout/blocking and grounding kits as required by local practice. Follow the installation instructions provided with each kit.
► Note: If a grounding kit is required, strip the cable sheath to the recommended length and install the grounding clamp prior to securing the cable to the cabinet.
5. Locate the cable clamping positions specified for securing the distribution cables to the cable bracket as shown in [Figure 28](#).
► Note: Use cable positions 3 and 5 for distribution cables that are greater than 0.8 inches in diameter that require large size cable clamps.
6. Locate the clamps, grommets, cover plates, and screws that are provided for securing the cable to the cabinet.
► Note: Two large cable clamps (for cables 0.8 inches or more in diameter) are provided for securing the distribution cable to the cabinet. Additional cable clamps must be ordered separately if more than one distribution cable will be installed or if small cable clamps (for cables smaller than 0.8 inches in diameter) are required. If additional large cable clamps are required, order kit FD3-ACCLGCLMP. If small cable clamps are required, order kit FD3-ACCSMCLMP.
7. Assemble each pair of clamps (and grommet if required) on the cable as shown in [Figure 29](#) and secure the cable to the cabinet at the selected cable clamping position.

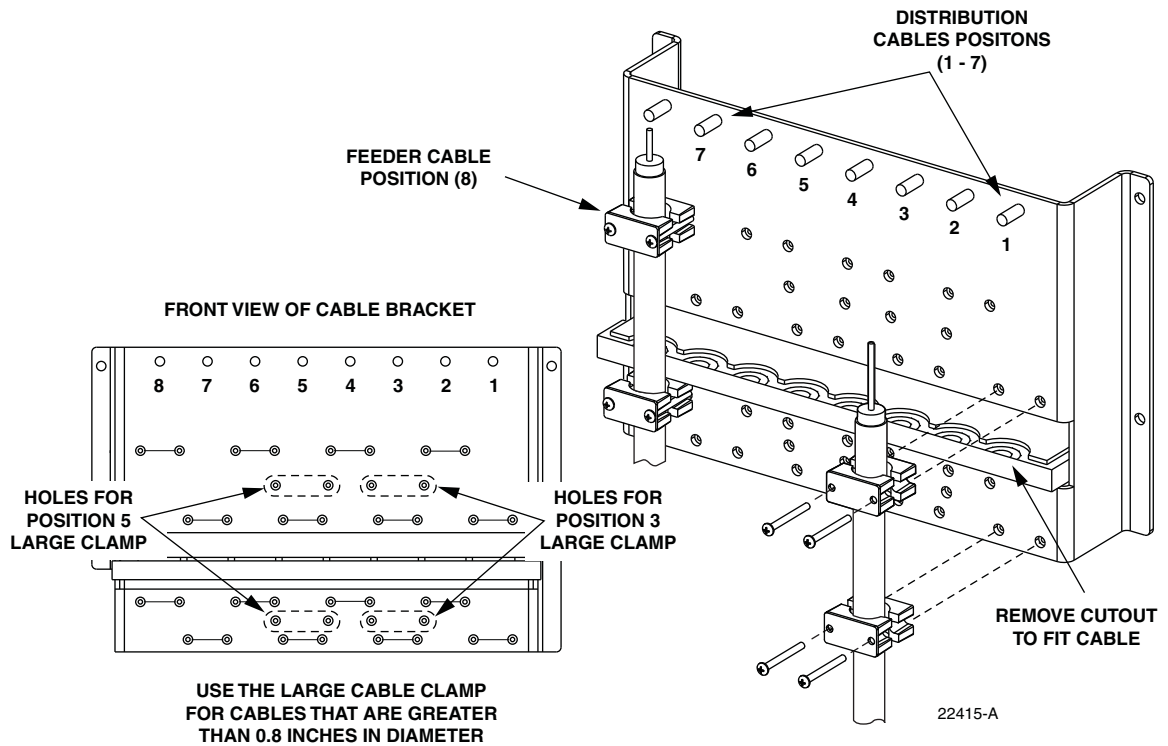

Figure 28. Secure Distribution Cable to Cable Bracket

► **Note:** Rubber plugs are inserted into the cable bracket holes to prevent insects from entering the cabinet. Remove only those rubber plugs necessary to allow installation of the distribution cable clamps. All other plugs should be left in place.

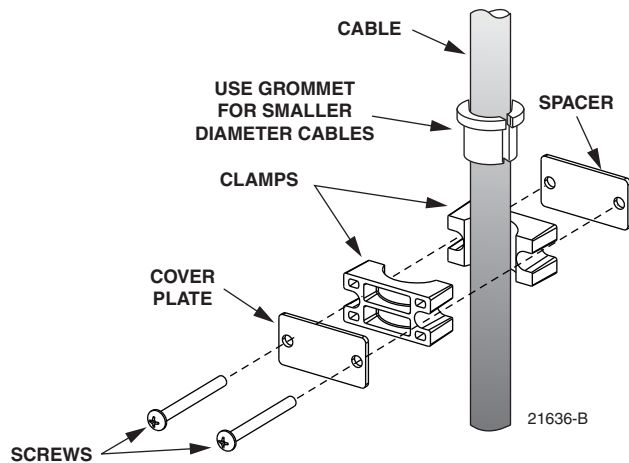

Figure 29. Cable Clamp Assembly

8. If the cable has a central strength member, locate the lug that is provided for clamping the strength member to the cable bracket. If the cable does not have a central strength member, proceed to step 11.
9. Insert the central strength member into the lug as shown in [Figure 19](#) and then install the lug on the cable bracket.

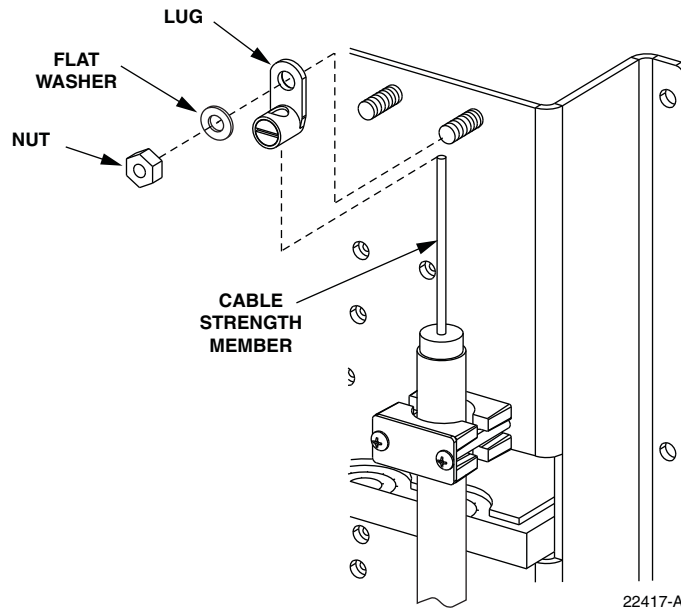

Figure 30. Strength Member Lug Installation

10. Trim the central strength member to length and tighten the lug set screw.
11. If a grounding kit was installed on the cable, refer to [Section 6.2](#) for the cable grounding procedure. If a grounding kit was not installed on the cable, refer to [Section 6.3](#) for the feeder cable splicing procedure.

6.2 Grounding the Distribution Cables

If a distribution cable is constructed with a metallic shield or other metallic components, then a grounding kit must be installed on the cable. The grounding kit should provide a stud for attaching a #6 AWG copper jumper wire to the distribution cable. Use the following procedure for grounding a distribution cable that has been fitted with a grounding kit:

1. Connect a #6 AWG stranded copper jumper wire (terminated with ring terminals) to the distribution cable grounding stud.
2. Locate the weather-seal strip attached to the right side of the cabinet grounding system as shown in [Figure 31](#).
3. Route the distribution cable jumper wire to the weather-seal strip as shown in [Figure 31](#) and push the free end of the wire through the hole that corresponds to the cable mounting position.

- **Note:** The fiber optic cables are numbered 1 – 8 starting with the first cable on the right side of the cable bracket. The holes for the grounding cables are numbered 1 – 8 starting with the top opening in the weather-seal strip.

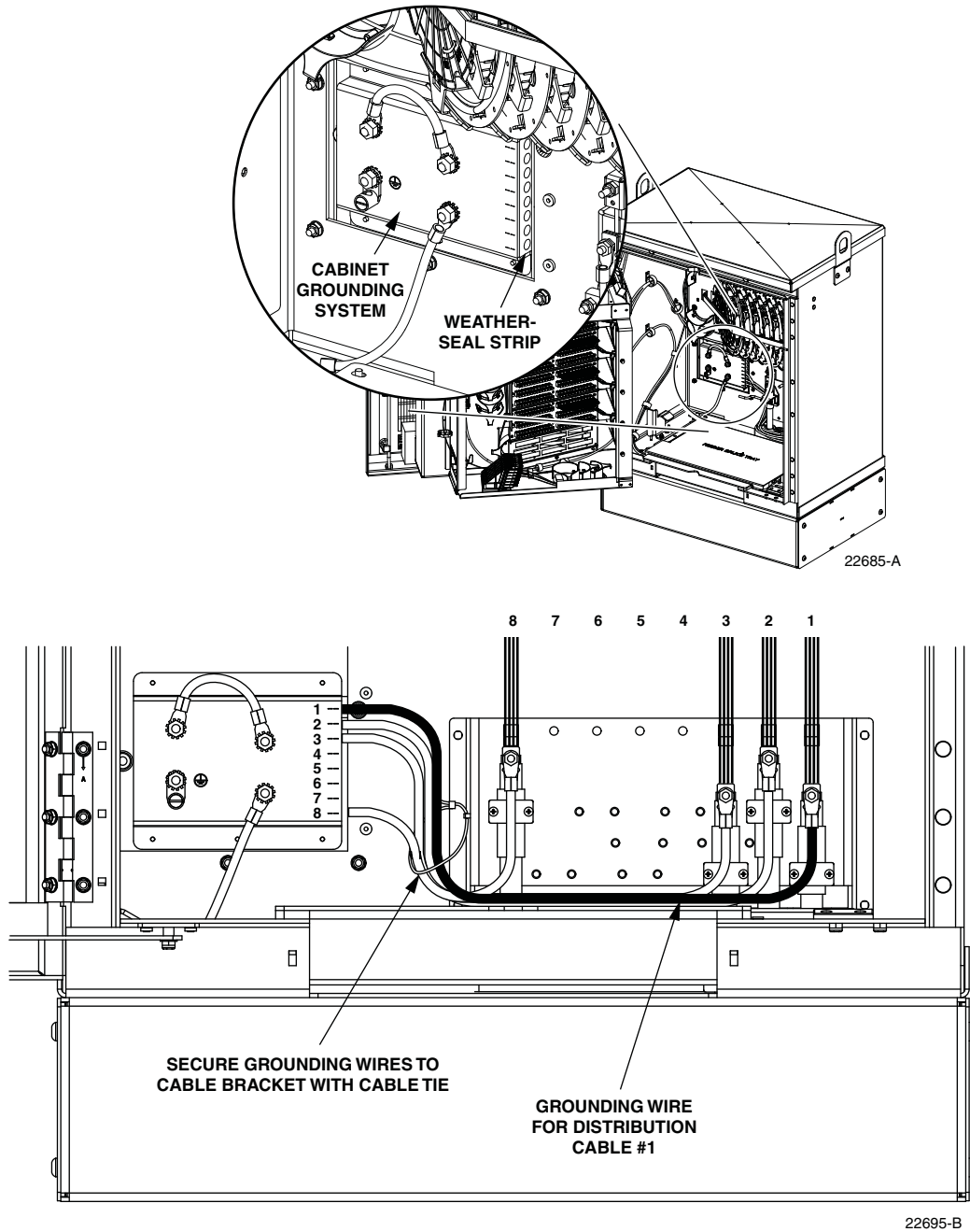

Figure 31. Route Grounding Cable to Grounding System

4. Open the grounding system access cover located at the rear side of the cabinet as shown in [Figure 32](#).

- Identify the grounding stud that corresponds to the cable mounting position.

► **Note:** A label on the back of the access cover indicates the grounding stud numbers.

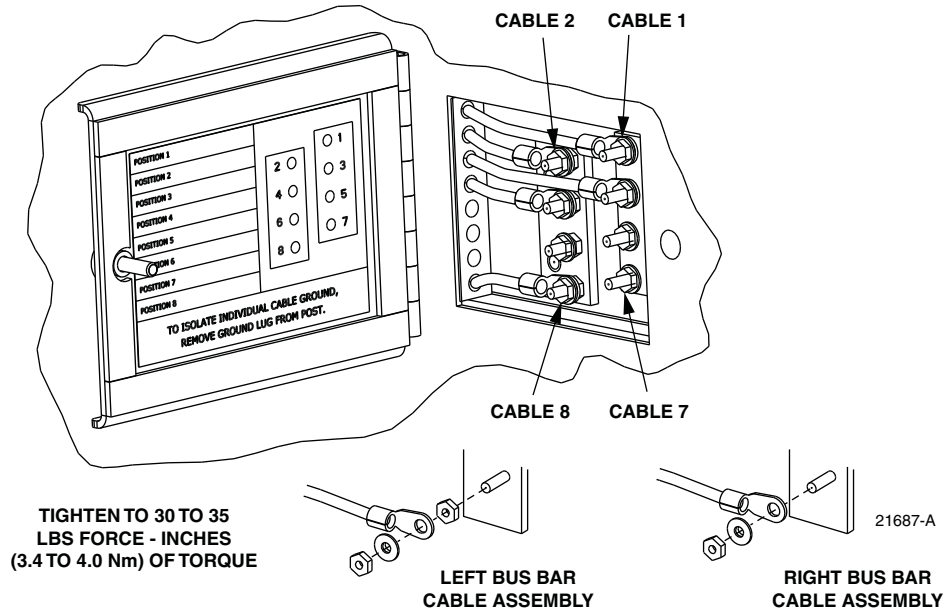

Figure 32. Cable Grounding System - Exterior View

- Connect the grounding jumper wire to the appropriate cable grounding stud.

► **Note:** Each grounding stud on the **left** bus bar is equipped with two nuts. When connecting a jumper wire to the **left** bus bar, place the cable terminal **between** the two nuts.

- Tighten the grounding stud nut to 30 to 35 lbs force-inches. (3.4 to 4.0 Nm) of torque.



Warning: The grounding cables are connected to cabinet ground through the copper grounding blocks. Failure to properly tighten the nut on each individual cable grounding stud could result in improper grounding of the cable and result in performance or safety issues.

- Close the cable grounding system access door and secure using the 216B tool.

6.3 Splicing the Distribution Cable Fibers

Depending on the option ordered, the cabinet may be equipped with up to 24 splice wheels for distribution cable splicing. Use the following procedure to route the distribution cable fibers to the splice trays and to splice the distribution cable fibers to the distribution panel pigtails:

1. Identify and locate the distribution panel subunits that are routed from the back of each panel to the splice wheels as shown in [Figure 33](#).
2. Unfasten the hook and pile strip that secures the top row of splice wheels to the back of the cabinet. Rotate the splice wheels outward so the distribution panel fibers and cable rings are visible.
3. Refer to [Figure 34](#) to identify and locate the splice wheels for distribution panel #1.

► **Note:** The pigtails from each distribution panel are grouped into six 12-fiber subunits and each subunit is routed to a splice wheel. The subunits are numbered from 1 – 24 and the individual fibers are numbered from 1 – 288. The splice wheels are arranged from left to right starting at the top and are labeled with the individual fiber/port numbers.

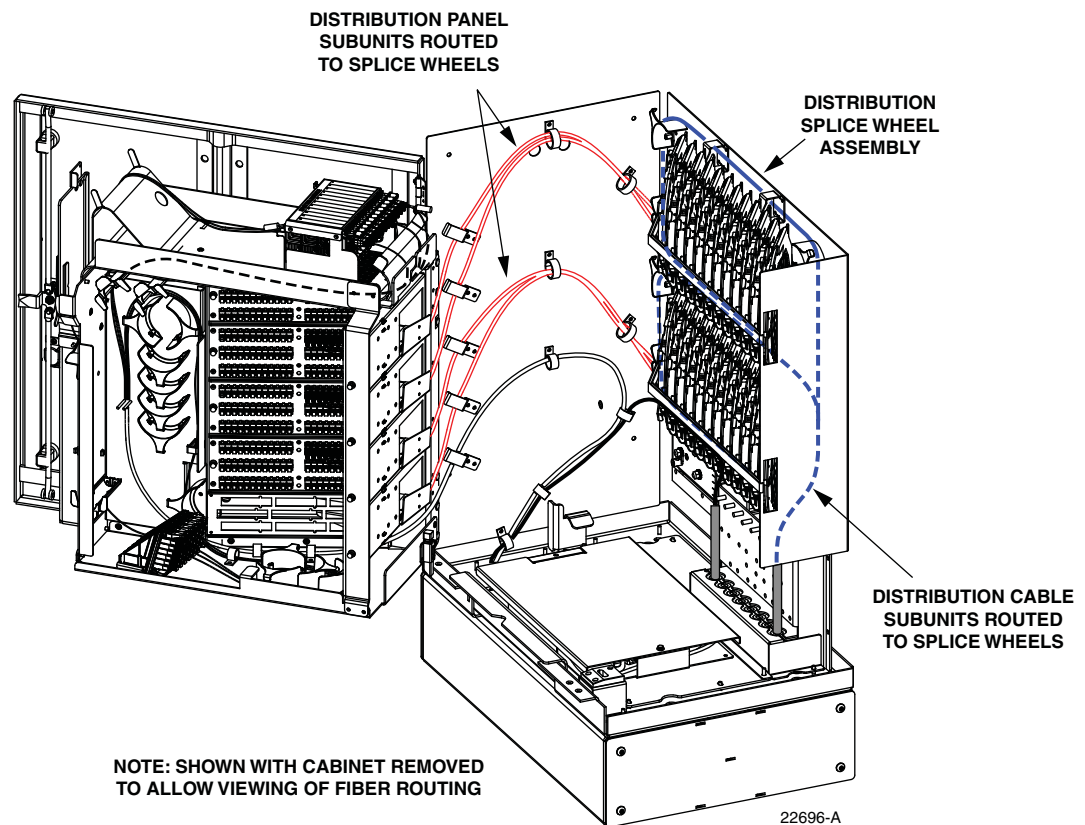

Figure 33. Distribution Splice Wheels and Distribution Panel Subunit Routing

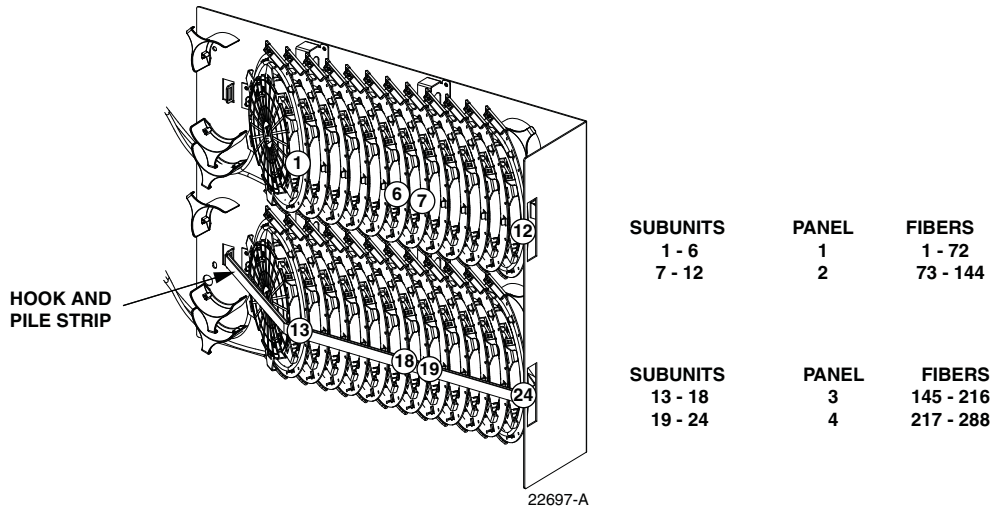

Figure 34. Distribution Splice Wheel Assembly

- Beginning at the distribution cable fiber breakout point, route each distribution cable subunit to the tie point below the appropriate splice wheel as shown in [Figure 35](#).

► **Note:** Each distribution panel subunit is secured to the cabinet at a point just below a splice wheel. Spiral wrap is placed over the subunit at the tie point to prevent the cable tie from compressing the fiber within the subunit.



Caution: Always allow sufficient fiber length to permit routing without severe bends. Non bend-optimized fibers may be permanently damaged if bent/curved to a radius of less than 1.5 inches (3.81 cm).

- Use cable ties or lacing to **loosely** secure each distribution fiber subunit to the appropriate distribution panel subunit at a point just above the spiral wrap as shown in [Figure 36](#).



Caution: Improper handling can damage fiber optic cables. Do not over tighten cable ties or lacing as this can cause damage or attenuation. Do not compress the fibers or allow them to kink.

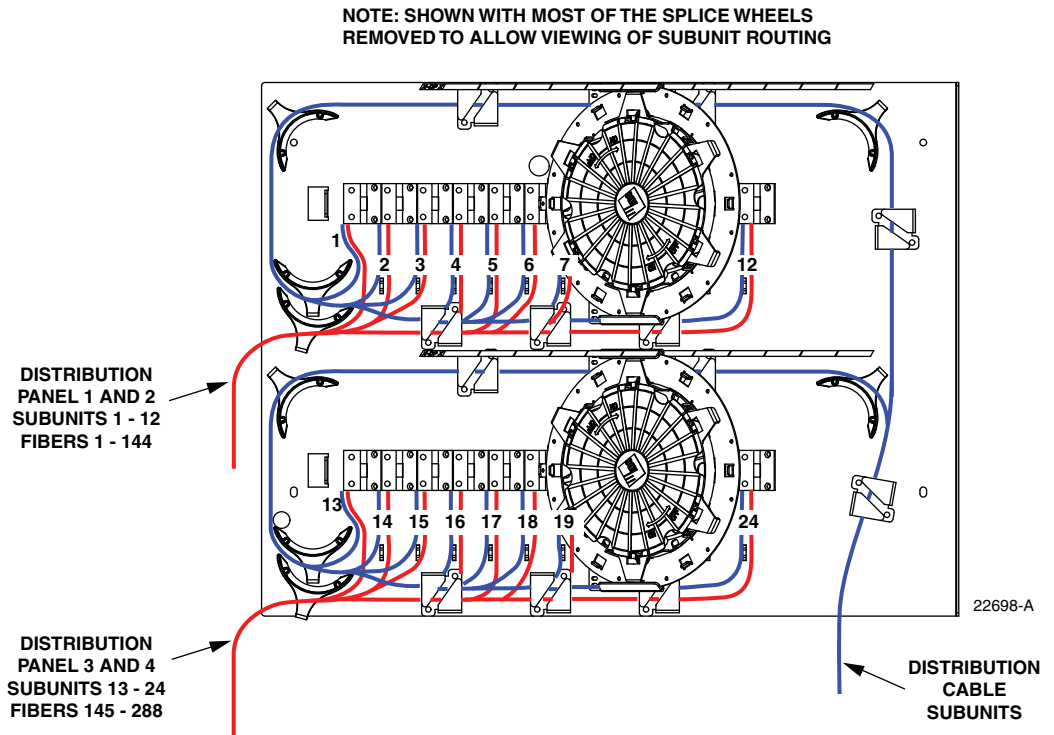

Figure 35. Distribution Cable Subunit Routing to Splice Wheels

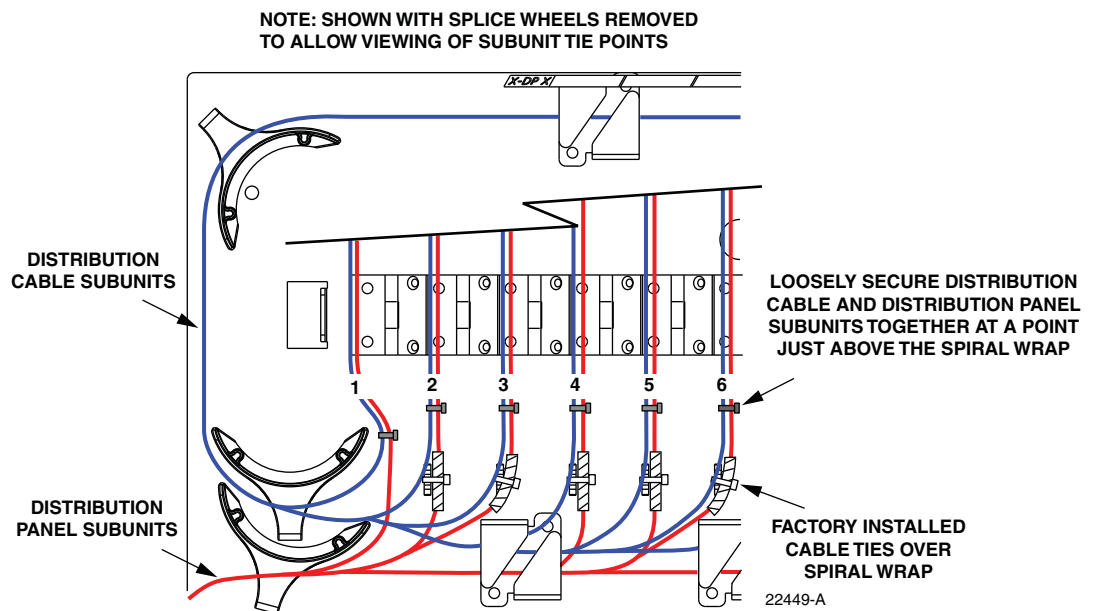

Figure 36. Securing the Distribution Cable Subunits

6. Remove the splice wheel for fibers/ports 1-12 from the cabinet and carefully unwind the the distribution panel subunit (uncoil to full length) that is coiled around the wheel.

7. Starting at the common tie point below the splice wheel, route the distribution cable subunit to the splice wheel. Make sure the distribution cable subunit and distribution panel subunit are same length as shown in [Figure 37](#).

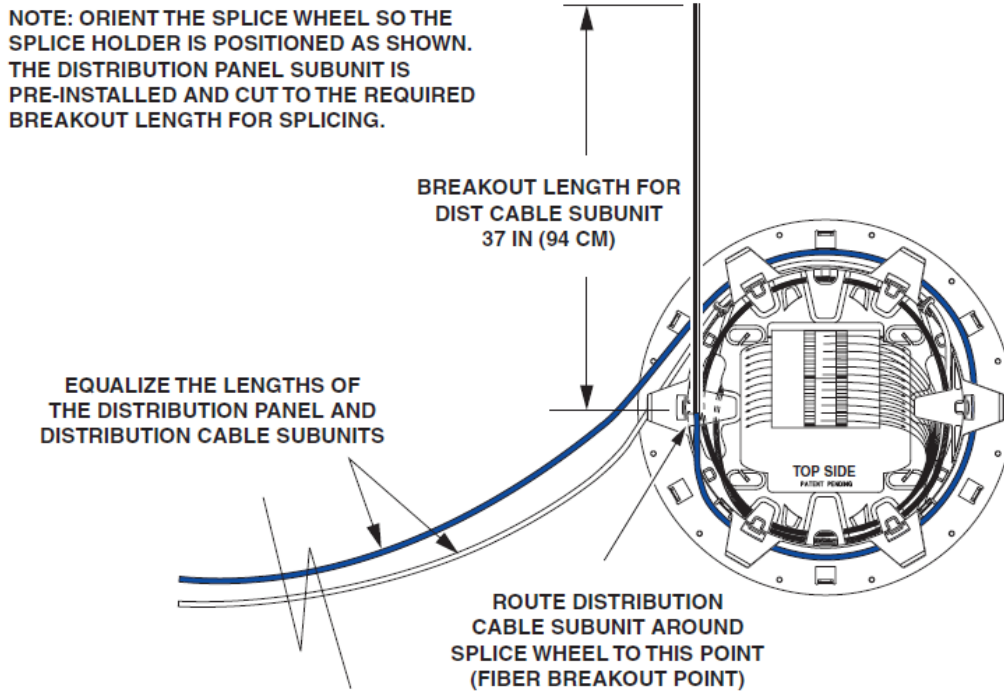

Figure 37. Equalize the Distribution Panel and Distribution Cable Subunit Lengths

8. Coil the distribution subunit once around the splice wheel and then mark the fiber breakout point (see [Figure 37](#)) on the outside of the subunit protective jacket.
9. From the point marked in step 8, trim the distribution cable breakout fibers to a breakout length of 37 inches (94 cm).
10. Starting at the breakout mark, remove the protective jacket to expose the distribution cable subunit fibers.
11. Remove the top cover from the splice wheel.
12. Secure the distribution cable subunit to the splice wheel at the points specified in [Figure 38](#).
13. Adjust the distribution cable subunit so the fiber breakout is positioned at the specified point (see [Figure 38](#)).

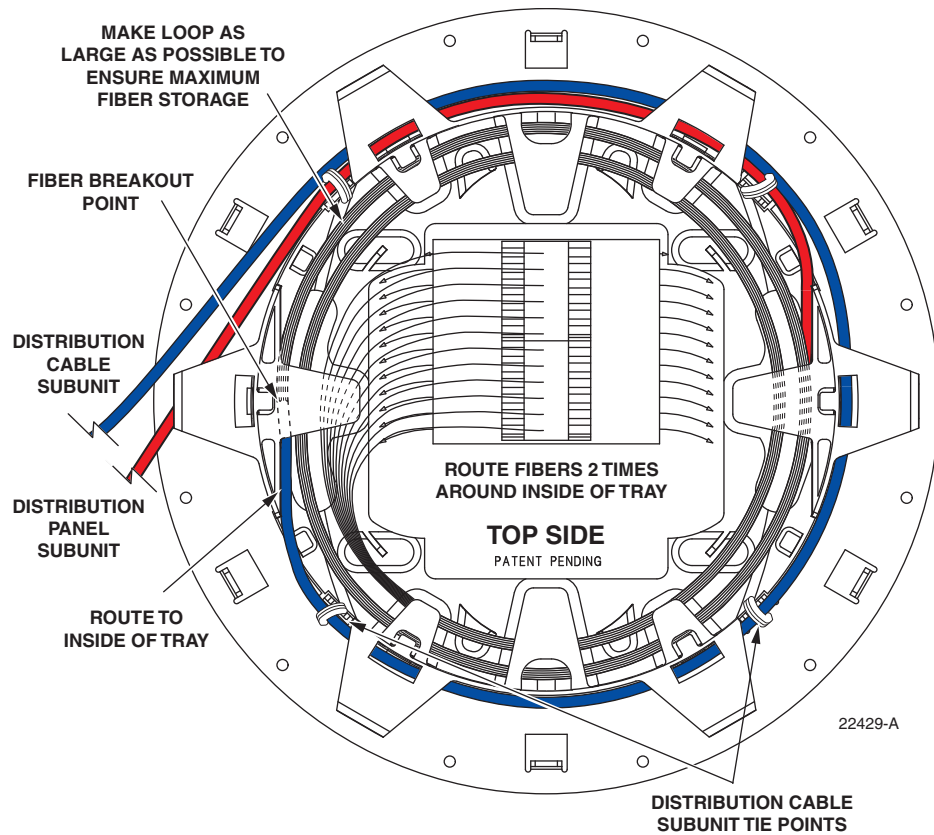

Figure 38. Installing Distribution Cable Subunit In Splice Wheel

14. Route the breakout fibers at least two times around the inside of the wheel making the loop as large as possible to ensure maximum fiber storage.
15. Splice the distribution panel fibers to the distribution cable fibers in accordance with local policies and procedures.
16. Replace the splice wheel top cover and then turn the splice wheel in a clockwise direction to roll up the excess slack as shown in [Figure 39](#)

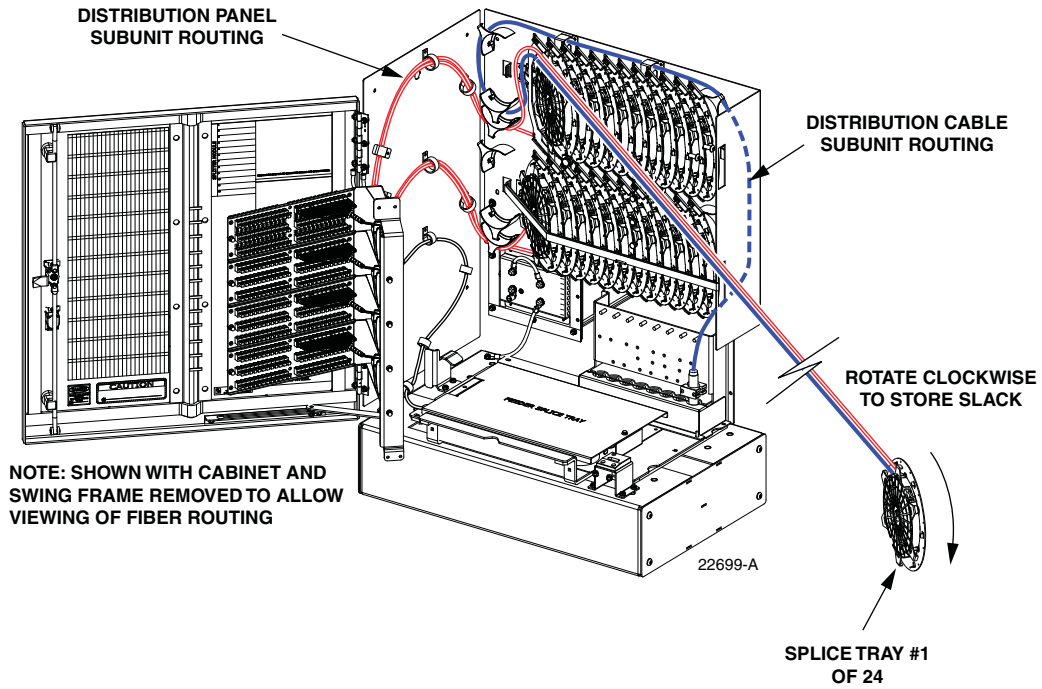

Figure 39. Store Excess Slack

17. When all the excess slack is stored on the splice wheel, reinsert the splice wheel into the original mounting slot.
18. Repeat this procedure for each distribution cable subunit.
19. When all splicing is completed, use the hook and pile straps to secure the rows of splice wheels in the closed position.
20. Reinstall the cable bracket cover as described in [Section 5.1](#) when all the distribution cables have been installed and spliced.
21. Designation labels are provided on the front door of the cabinet for recording subscriber information. For each optical port, indicate the subscriber address and service information.

7 PLUG AND PLAYER SPLITTER MODULE INSTALLATION

The 288 cabinet can accommodate up to 12 splitter modules. Plug and play splitter modules are equipped with either one or two input connectors. Inserting the splitter into the splitter compartment connects the splitter input connector(s) to the feeder cable connector(s). The splitter output fibers may be stored for later use or routed to the distribution panels for connection to the distribution ports. Additional instructions for installing plug and play splitter modules are provided in the FDH 3000 Plug and Play Splitter Installation Guide (ADCP-96-087). Use only splitters equipped with bend-optimized fibers.

Use the following procedure to install additional splitters in the cabinet:

1. Locate the next available splitter mounting position as shown in [Figure 40](#).

► **Note:** Install splitters in the order shown, beginning on the left side of the splitter compartment and then working toward the right.

2. Remove the dust cap assembly from the selected splitter slot.

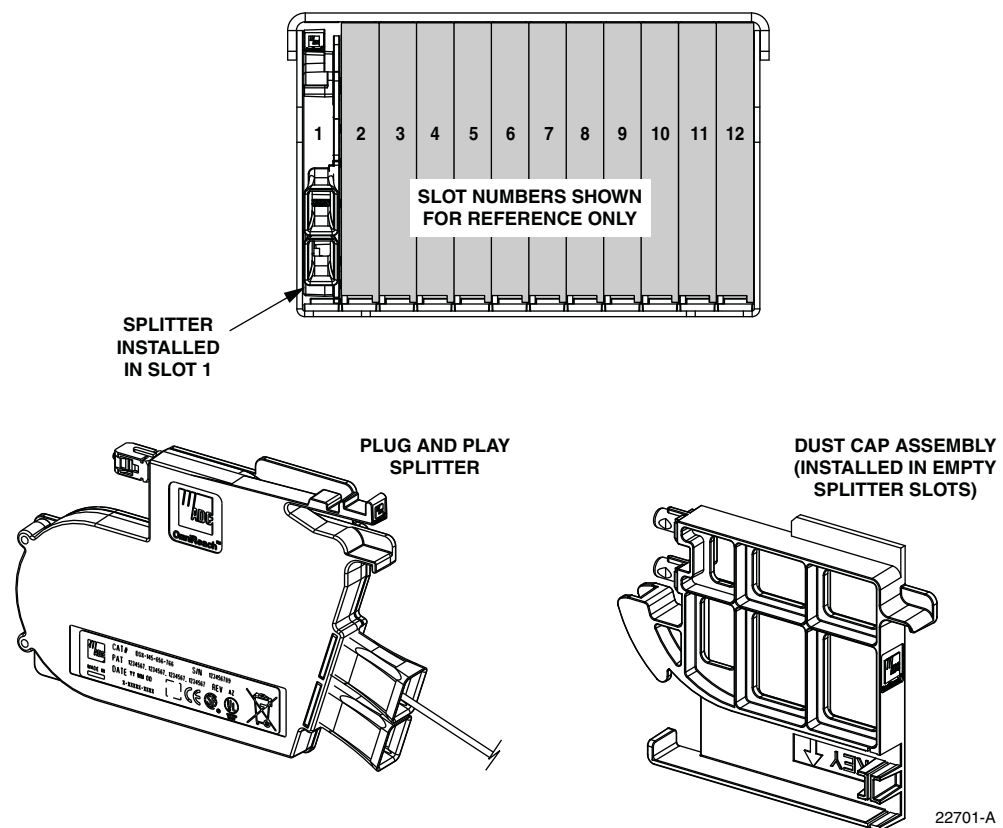

Figure 40. Splitter Module Installation

3. Remove the corresponding feeder cable connector(s) from the rear of the splitter compartment as shown in [Figure 41](#).



Warning: Infrared radiation is invisible and can seriously damage the retina of the eye. Do not look into the ends of any optical fiber. Do not look directly into the optical adapters or connectors. Exposure to invisible laser radiation may result. An optical power meter should be used to verify active fibers. A protective cap or hood **MUST** be immediately placed over any radiating adapter or optical connector to avoid the potential of dangerous amounts of radiation exposure. This practice also prevents dirt particles from entering the adapter or connector.

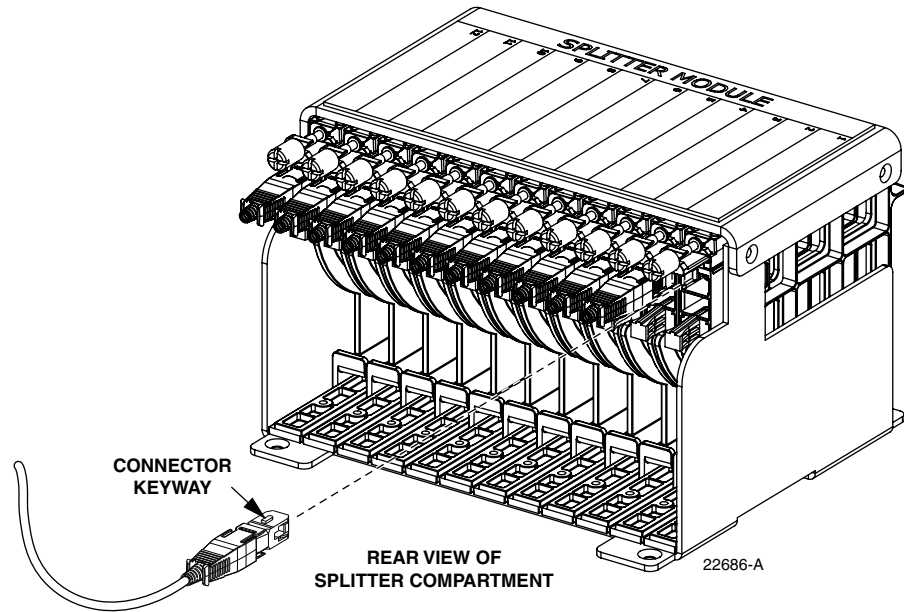

Figure 41. Feeder Cable Connector - Typical Compartment Shown

4. Clean the feeder cable connector(s) as specified in the Optical Fiber Systems Cleaning and Mating Instructions (ADCP-90-159).
5. Reinstall the feeder cable connector(s) at the rear of the splitter compartment.
6. Insert the splitter into the mounting slot as shown in [Figure 42](#).
7. Route the splitter output fibers to the connector storage panel or to the designated subscriber port. Refer to [Section 8](#) for the routing procedure.
8. Designation labels are provided on the front door of the cabinet for recording splitter information. For each splitter, indicate the splitter type and related service information.

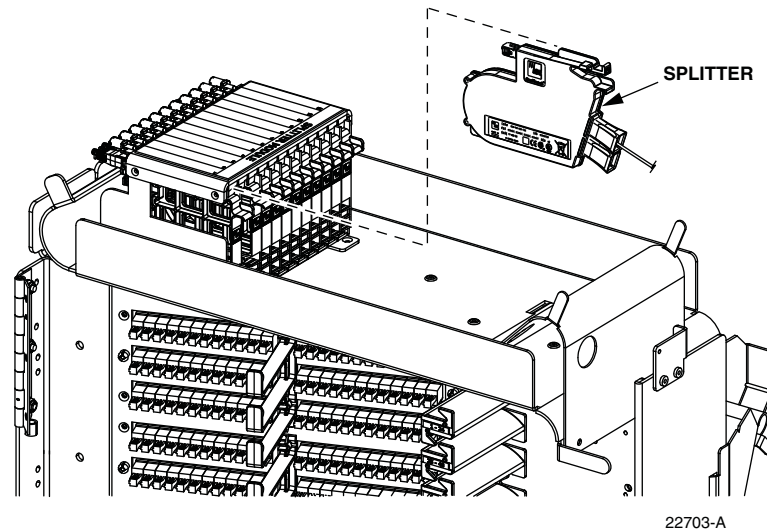

Figure 42. Splitter Installation

8 ROUTING AND CONNECTING THE SPLITTER OUTPUT FIBERS

The splitter modules are mounted at the top of the 288 cabinet. When a splitter module is initially installed, the output fibers are routed to the storage panel located at the bottom of the cabinet. At the storage panel, the output fibers are temporarily “parked” until they are needed. Service to a subscriber is enabled by removing an unused output fiber from the storage panel, routing it to the appropriate distribution panel, and then connecting it to the subscriber port.

8.1 Storing The Splitter Output Fibers

Use the following procedure to store the splitter output fibers.

1. Following installation of a splitter module, locate an open connector pack slot in the storage panel at the bottom of the cabinet.
2. Insert the connector pack into the unused slot in the storage panel. Refer to the FDH 3000 Plug and Play Splitter Installation Guide (ADCP-96-087) provided with splitter modules for additional information on installing connector packs in the storage panel.
3. Use the radius limiters on the right side of the cabinet to store any excess fiber slack. Refer to [Figure 43](#) for the routing guidelines.

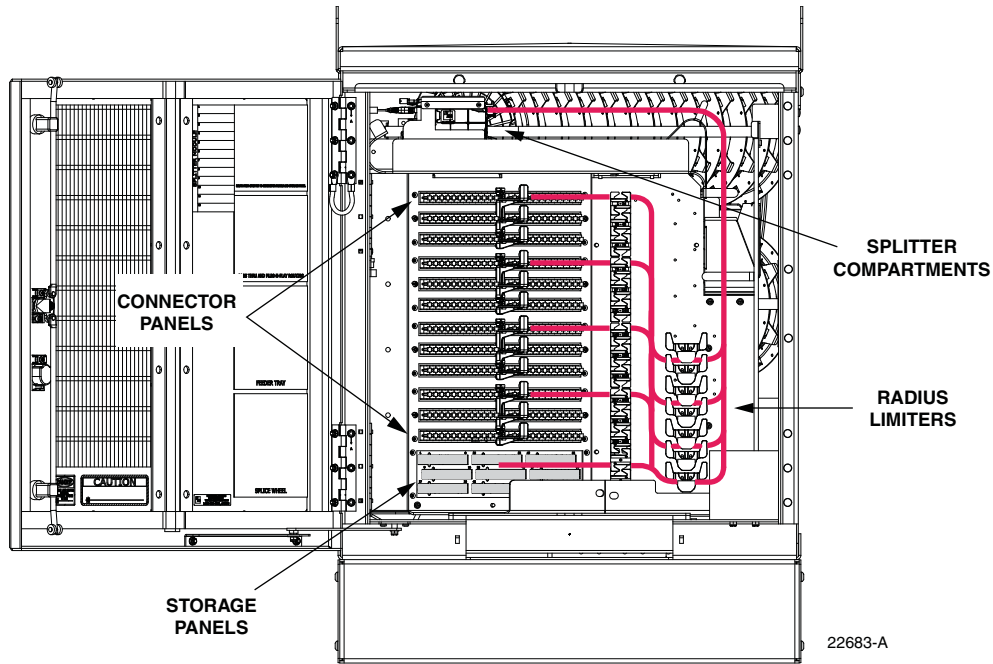

Figure 43. Routing Splitter Output Fibers

8.2 Enabling Service To a Subscriber

Use the following procedure to enable service to a subscriber:

1. Check the designation labels on the cabinet doors to determine the distribution panel and port number that corresponds to the address of the subscriber.
2. Locate the subscriber port on the specified distribution panel and remove both the adapter dust cap and the connector ferrule dust cap.
3. Select and remove an unused splitter output fiber from the storage panel and carefully work it free of any other fibers.



Warning: *Infrared radiation is invisible and can seriously damage the retina of the eye. Do not look into the ends of any optical fiber. Do not look directly into the optical adapters or connectors. Exposure to invisible laser radiation may result. An optical power meter should be used to verify active fibers. A protective cap or hood MUST be immediately placed over any radiating adapter or optical connector to avoid the potential of dangerous amounts of radiation exposure. This practice also prevents dirt particles from entering the adapter or connector.*

4. Remove the ferrule dust cap from the connector and then clean the connector as specified in the Optical Fiber Systems Cleaning and Mating Instructions (ADCP-90-159).
5. Connect the splitter output fiber connector to the subscriber port.
6. Use the radius limiters on the right side of the cabinet to store any excess fiber slack. Refer to [Figure 43](#) for the routing guidelines

9 PASS-THROUGH ROUTING PROCEDURES

Pass-through routing is used when it is necessary for a feeder cable optical signal to be routed directly to a distribution port. This involves connecting a patch cord between the terminated feeder cable connector and the appropriate distribution port. Because feeder cable fibers can be terminated at either the sliding adapter pack or the splitter compartment, two pass-through routing procedures are provided.

9.1 Sliding Adapter Pack Pass-Through Routing Procedure

Use the following procedure to route a jumper patch cord between the feeder cable sliding adapter pack and one of the distribution panels.

1. Locate the appropriate feeder cable connector on the sliding adapter pack.
2. Pull upward on the small tab on top of the adapter pack and lift the adapter pack to the position shown in [Figure 44](#).

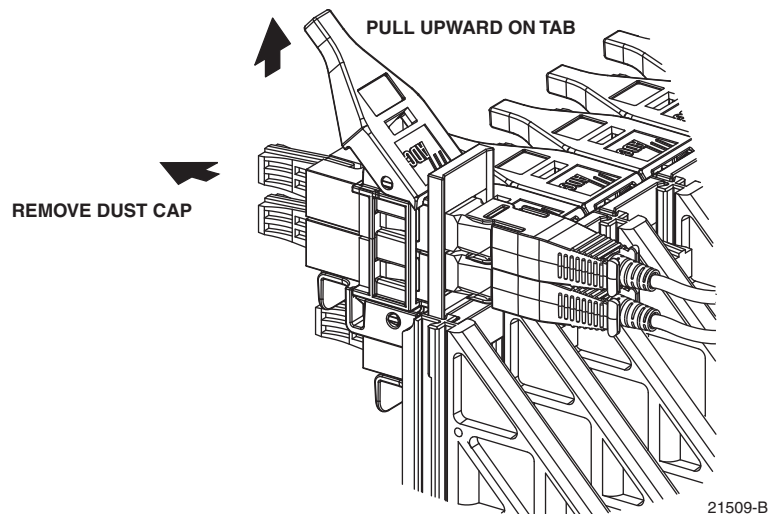

Figure 44. Typical Adapter Pack Raised to Access Position



Warning: *Infrared radiation is invisible and can seriously damage the retina of the eye. Do not look into the ends of any optical fiber. Do not look directly into the optical adapters or connectors. Exposure to invisible laser radiation may result. An optical power meter should be used to verify active fibers. A protective cap or hood MUST be immediately placed over any radiating adapter or optical connector to avoid the potential of dangerous amounts of radiation exposure. This practice also prevents dirt particles from entering the adapter or connector.*

3. Remove the dust cap from the appropriate bulkhead adapter in the sliding adapter pack.
4. Obtain the optical patch cord (accessory) recommended for the pass-through connection.

► **Note:** Use catalog# FPCFW-APSC-P-2.1M for APC/SC connectors.
Use catalog# FPCFW-SPSC-P-2.1M for UPC/SC connectors.

5. Remove the ferrule dust cap from one of the patch cord connectors and then clean the connector as specified in the Optical Fiber Connector Wet and Dry Cleaning Instructions (ADCP-90-159) or by locally approved procedures.
6. Insert the patch cord connector into the bulkhead adapter in the sliding adapter pack.
7. Slide the adapter pack down into the closed position.
8. Route the pass-through patch cord to the front side of the swing-out assembly as shown in [Figure 45](#).

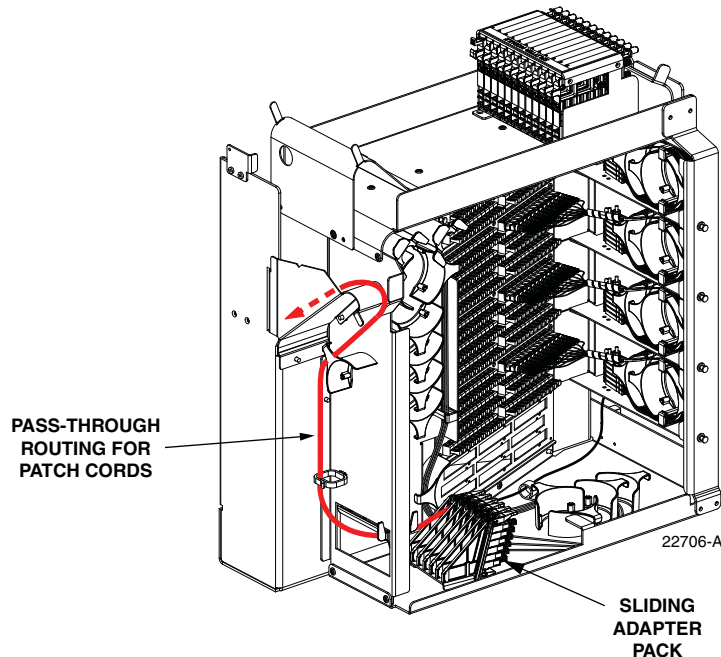

Figure 45. Routing Pass-Through Patch Cord From Sliding Adapter Pack

9. Locate the distribution panel and the optical port to which the pass-through patch cord is to be routed.
10. Refer to the procedures in [Section 8.2](#) to route the pass-through patch cord to the distribution panel and to connect the patch cord connector to the appropriate optical port.

9.2 Splitter Compartment Pass-Through Routing Procedure

Use the following procedure to route a jumper patch cord between the splitter compartment and one of the distribution cable distribution panels.

1. Locate an open splitter mounting position.
2. Remove the dust cap assembly from the selected splitter slot.
3. Remove the feeder cable connector(s) from the rear of the splitter compartment (see [Figure 41](#)).



Warning: Infrared radiation is invisible and can seriously damage the retina of the eye. Do not look into the ends of any optical fiber. Do not look directly into the optical adapters or connectors. Exposure to invisible laser radiation may result. An optical power meter should be used to verify active fibers. A protective cap or hood **MUST** be immediately placed over any radiating adapter or optical connector to avoid the potential of dangerous amounts of radiation exposure. This practice also prevents dirt particles from entering the adapter or connector.

4. Clean the feeder cable connector(s) as specified in the Optical Fiber Systems Cleaning and Mating Instructions (ADCP-90-159).
5. Reinstall the feeder cable connector(s) at the rear of the splitter compartment.
6. Obtain the optical patch cord (accessory) recommended for the pass-through connection.
7. Remove the ferrule dust cap from one of the patch cord connectors and then clean the connector as specified in the Optical Fiber Connector Wet and Dry Cleaning Instructions (ADCP-90-159) or by locally approved procedures.
8. Install the patch cord connector in the dust cap assembly as shown in [Figure 46](#).

► **Note:** Two patch cord connectors may be installed in the dust cap assembly if required.

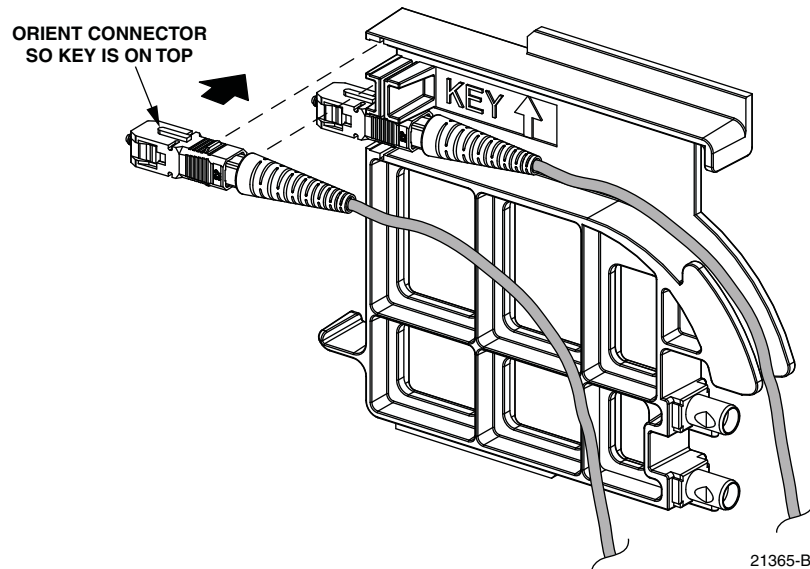

Figure 46. Installing Patch Cord Connector in Dust Cap Assembly

9. Connect the patch cord connector(s) to the feeder cable connector(s) by inserting the dust cap assembly into the splitter slot as shown in [Figure 47](#).
10. Locate the distribution panel and the optical port to which the pass-through patch cord is to be routed.
11. Refer to the procedures in [Section 8.2](#) to route the pass-through patch cord to the distribution panel and to connect the patch cord connector to the appropriate optical port.

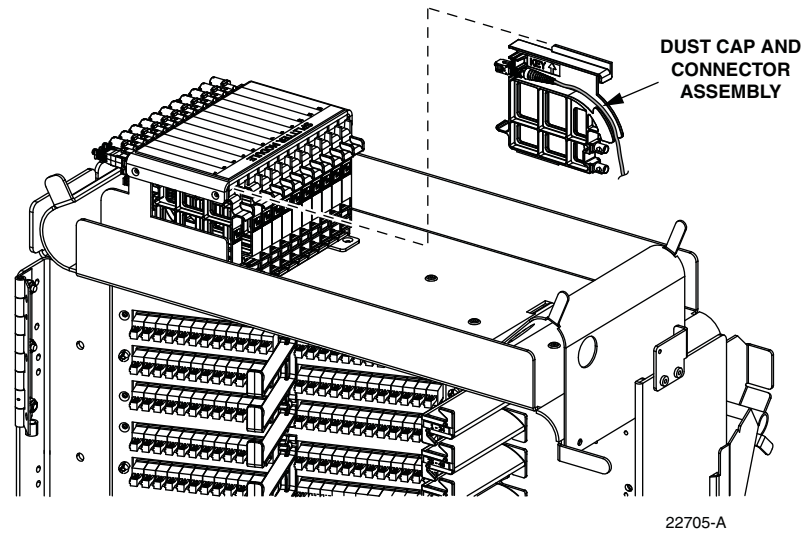

Figure 47. Inserting Dust Cap Assembly Into Splitter Compartment

10 MAINTENANCE AND REPAIR PROCEDURES

The 288 cabinet requires no regular maintenance to insure continuous and satisfactory operation. Maintenance is limited to repairing or replacing any cabinet components that may be damaged or broken in the course of normal operation. The following sections provide procedures for repairing or replacing common cabinet components.

10.1 Painting

Brush-in-cap type bottles of paint are available for touching-up nicks and scratches in the factory coat of paint. Lightly sand the area to be painted and then clean it thoroughly to remove any dirt, dust, or foreign matter. Shake the paint bottle until thoroughly mixed and then apply a light coat of paint to the damaged area using the small brush attached to the cap. Wait until the paint is dry and then apply a second coat if necessary. When finished painting, replace the paint bottle cap and tighten securely.

10.2 Distribution Panel Adapter Replacement

Replacement adapters are available for the distribution panels. Use the following procedure to remove and replace a damaged adapter:

1. Disconnect the splitter connector from the front side of the broken adapter as shown in [Figure 48](#) and install a dust cap on the connector.



Warning: *Infrared radiation is invisible and can seriously damage the retina of the eye. Do not look into the ends of any optical fiber. Do not look directly into the optical adapters or connectors. Exposure to invisible laser radiation may result. An optical power meter should be used to verify active fibers. A protective cap or hood **MUST** be immediately placed over any radiating adapter or optical connector to avoid the potential of dangerous amounts of radiation exposure. This practice also prevents dirt particles from entering the adapter or connector.*

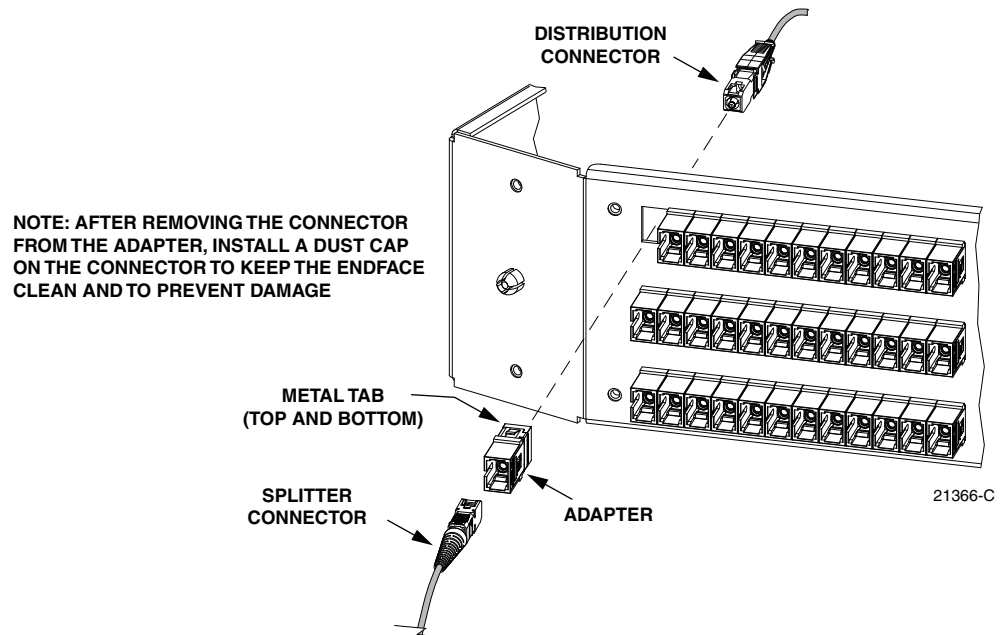

Figure 48. Adapter Removal and Replacement - Typical Distribution Panel

2. Unlatch and fully open the cabinet swing frame to provide access to the rear side of the distribution panel.
3. Disconnect the distribution connector from the rear side of the broken adapter and install a dust cap on the connector.



Caution: *Use extreme care when removing a connector or an adapter from the distribution panel to avoid macro bending the adjacent fibers.*

4. Working from the rear side of the distribution panel, use the SC adapter removal tool (catalog # FCC-ACC003) to depress the two metal tabs that retain the adapter in the panel. Then push forward on the adapter until it pops out of the panel.
5. Discard the damaged adapter.
6. Install the replacement adapter by inserting it into the distribution panel from the front and then pushing it toward the back until it snaps into place.

► **Note:** Make sure the keyway in the replacement adapter is facing in the same direction as the keyways in the rest of the adapters installed in the distribution panel.

7. Clean the distribution and splitter fiber connectors as specified in the Optical Fiber Systems Cleaning and Mating Instructions (ADCP-90-159).
8. Connect the distribution connector to the rear side of the replacement adapter.
9. Close the cabinet swing frame.
10. Connect the splitter connector to the front side of the replacement adapter.

10.3 Splitter Compartment Adapter Replacement

Replacement adapter assemblies are available for the splitter compartment. Use the following procedure to remove and replace a damaged adapter assembly:

1. Unlatch and fully open the cabinet swing frame to provide access to the both the front and rear side of the splitter compartment.
2. Remove the splitter or the dust cap assembly from the front side of the broken adapter assembly.



Warning: *Infrared radiation is invisible and can seriously damage the retina of the eye. Do not look into the ends of any optical fiber. Do not look directly into the optical adapters or connectors. Exposure to invisible laser radiation may result. An optical power meter should be used to verify active fibers. A protective cap or hood **MUST** be immediately placed over any radiating adapter or optical connector to avoid the potential of dangerous amounts of radiation exposure. This practice also prevents dirt particles from entering the adapter or connector.*

3. Remove the feeder cable connector(s) from the rear side of the broken adapter assembly as shown in [Figure 49](#) and install a dust cap on the connector(s).
4. Turn the thumb screw on the top of the broken adapter assembly clockwise until the adapter assembly detaches from the top of the splitter compartment.
5. Discard the damaged adapter assembly.
6. Install the replacement adapter assembly in the splitter compartment and secure it by turning the thumbscrew counter-clockwise until tight.
7. Clean the feeder cable connector(s) as specified in the Optical Fiber Systems Cleaning and Mating Instructions (ADCP-90-159).
8. Connect the feeder cable connector to the rear side of the replacement adapter assembly.
9. Connect the dust cap or splitter to the front side of the replacement adapter assembly.
10. Close the cabinet swing frame.

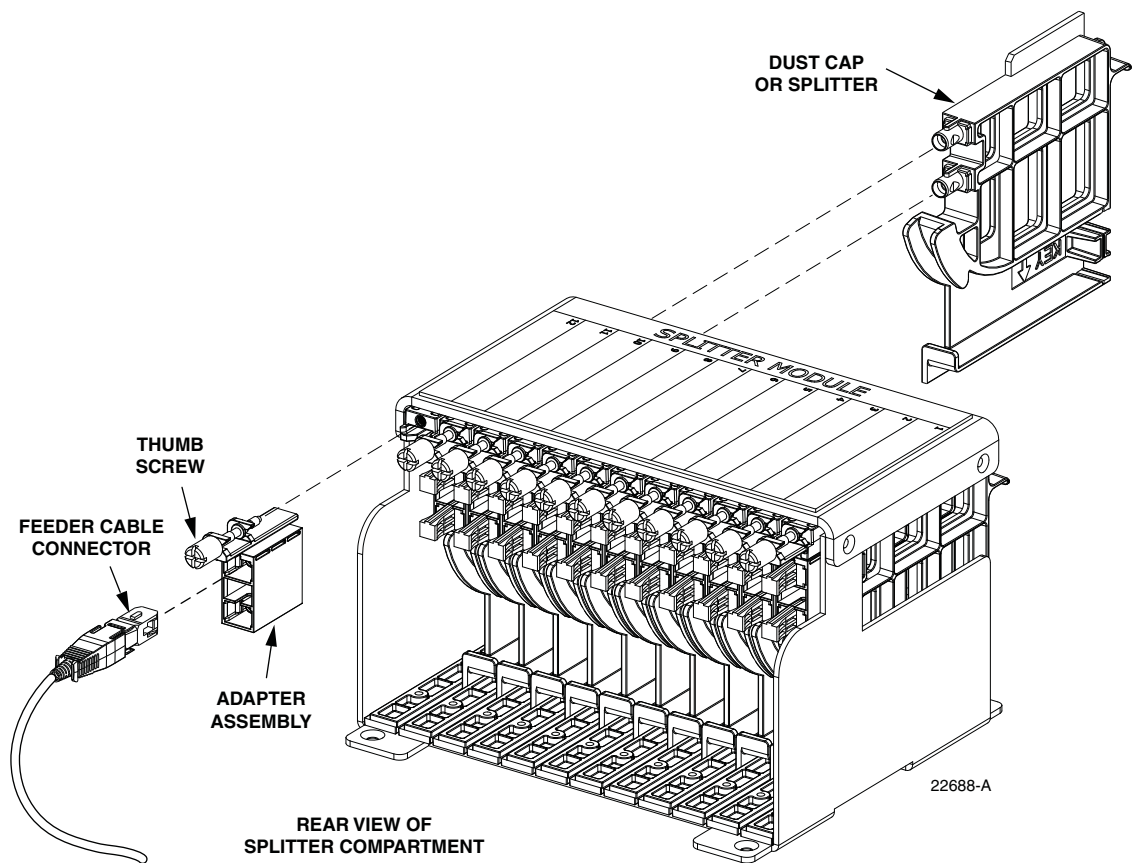

Figure 49. Splitter Compartment Adapter Replacement - Typical Compartment

10.4 Replacing a Damaged Fiber or Connector

A damaged fiber or connector can usually be replaced. The following describes the various replacement options.

- **Damaged Splitter Output Fiber:** Replace the splitter output fiber from the connector all the way back into the splitter. Splice a new pigtail (use only pigtails with bend-optimized fiber) to the remaining section of the old fiber within the splitter chassis. This procedure requires removing and disassembling the splitter to insert a splice chip and to perform the splice. A kit is available from ADC. Refer to ADCP-96-034 for the procedure.
- **Damaged Distribution or Feeder Connector:** Replace the connector at the bulkhead adapter if just the connector alone is damaged. Use a field-installable connector replacement kit. Refer to [Section 10.4.1](#) for the replacement procedures.

10.4.1 Splitter Output Fiber Connector Replacement

Use the following procedure to replace the connector:

1. Disconnect the damaged connector and the good connector from the adapter and install a dust cap on the good connector.



Warning: *Infrared radiation is invisible and can seriously damage the retina of the eye. Do not look into the ends of any optical fiber. Do not look directly into the optical adapters or connectors. Exposure to invisible laser radiation may result. An optical power meter should be used to verify active fibers. A protective cap or hood MUST be immediately placed over any radiating adapter or optical connector to avoid the potential of dangerous amounts of radiation exposure. This practice also prevents dirt particles from entering the adapter or connector.*

2. Replace the damaged connector as specified in the procedures provided with the field-installable connector replacement kit.
3. Clean both connectors as specified in the Optical Fiber Connector Wet and Dry Cleaning Instructions (ADCP-90-159) or by locally approved procedures.
4. Reconnect the good connector and the replacement connector to the adapter.

10.5 Door Gasket Replacement

Damaged door gaskets may be replaced using the door gasket kit which includes a roll of gasket material. The ideal installation temperature for the adhesive used on the replacement gaskets is between 60 and 100 °F (16 and 38 °C). Installation is not recommended if the temperature is below 50 °F (10 °C). Remove any damaged sections of gasket material from the door. If necessary, use a citrus based adhesive cleaner to remove any adhesive that may stay attached to the door. Cut replacement lengths of gasket material from the roll as needed. Remove the paper backing to expose the adhesive and then carefully apply the replacement gasket to the door. Take care not to leave any gaps between the meeting sections of the gasket strips.

10.6 Door Replacement

Damaged cabinet doors may be replaced using the door replacement kit. Use the following procedure to remove and replace the cabinet doors:

1. Open the cabinet door and lock it in the open position as shown in [Figure 50](#).
2. Use a 3/8-inch nut driver to remove the locking nuts and washers that secure the door bracket slide to the bottom edge of the door as shown in [Figure 51](#). Save the nuts and washers for reuse.
3. Use a 3/8-inch nut driver to remove the locking nuts that secure the hinges to the door. Save nuts for reuse.

► **Note:** Support the door as the last nuts are removed to prevent the door from falling.

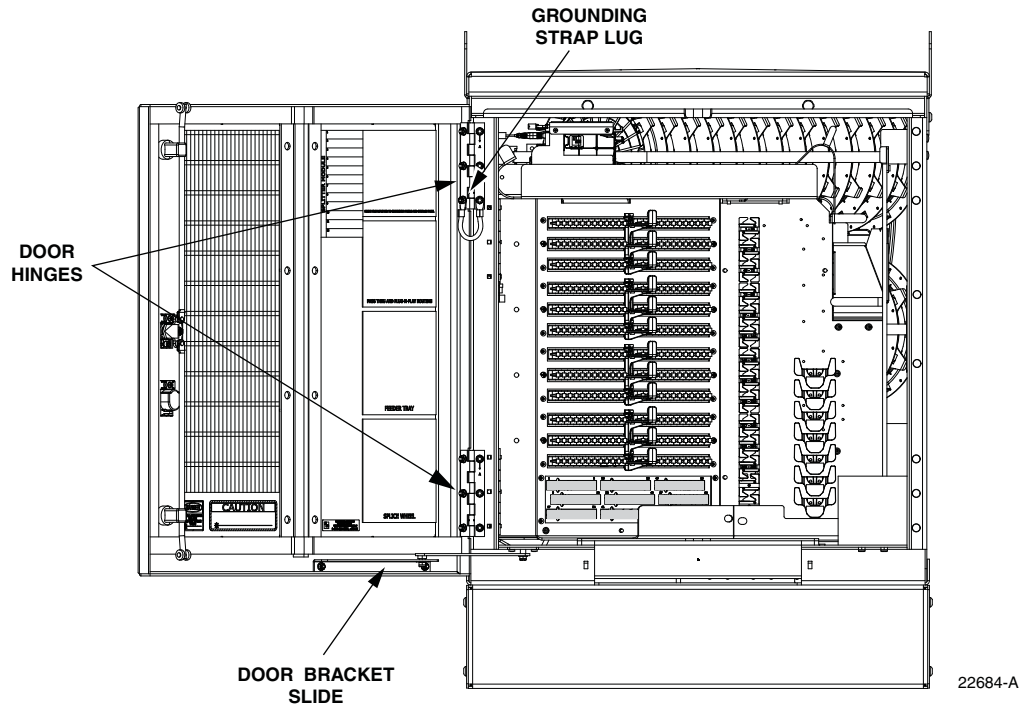

Figure 50. Door Replacement

4. Carefully lift the door away from the cabinet.
 5. Transfer all designation information that may be recorded on the damaged door to the labels on the replacement door.
 6. Place the replacement door in position for installation on the hinges.
 7. Reinstall the locking nuts (saved in step 3) that secure each hinge to the door.
- **Note:** Be sure to re-secure the grounding strap lug (see [Figure 50](#)) to the door when securing the hinges to the door.
8. Secure the door bracket slide to the bottom edge of the door using the locking nuts and washers saved in step 2.
 9. Close door and check for proper operation.

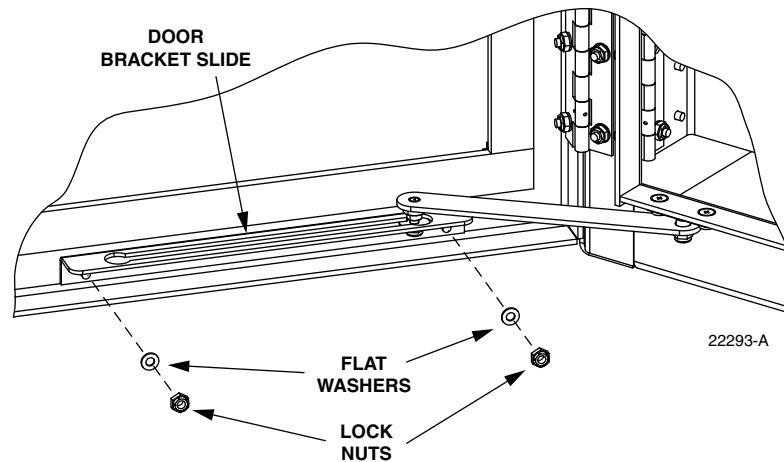

Figure 51. Door Bracket Slide Hardware

10.7 Grounding System Terminal Access Procedure

Fiber optic cables with metallic strength members or shields are grounded to a common grounding system. The grounding system is designed to allow the metallic elements of each cable to be isolated for connection of cable locating equipment. The grounding system terminals may be accessed through a small cover located on the rear side of the cabinet. Use the following procedure to access and isolate the metallic elements of individual cables:

1. Locate the small hinged access cover at the rear side of the cabinet as shown in [Figure 52](#).
2. Use the 216B tool to remove the screw that secures the access cover in the closed position.
3. Swing open the cover and locate the grounding stud that corresponds to the cable to be located.

► **Note:** A designation label is provided on the access cover for identifying cables.

4. Remove the stud nut and disconnect the cable so that it is not touching the copper bus bar assembly.
5. Attach cable detection equipment to the isolated grounding cable and complete the cable location procedure.
6. When finished locating cables, reconnect the cable terminal to the grounding stud.
7. Tighten the grounding stud nut to 30 to 35 lbs force-inches. (3.4 to 4.0 Nm) of torque.



Warning: *The grounding cables are connected to cabinet ground through the copper grounding blocks. Failure to properly tighten the nut on each individual cable grounding stud could result in improper grounding of the cable and result in performance or safety issues.*

8. Close and secure grounding block access cover.

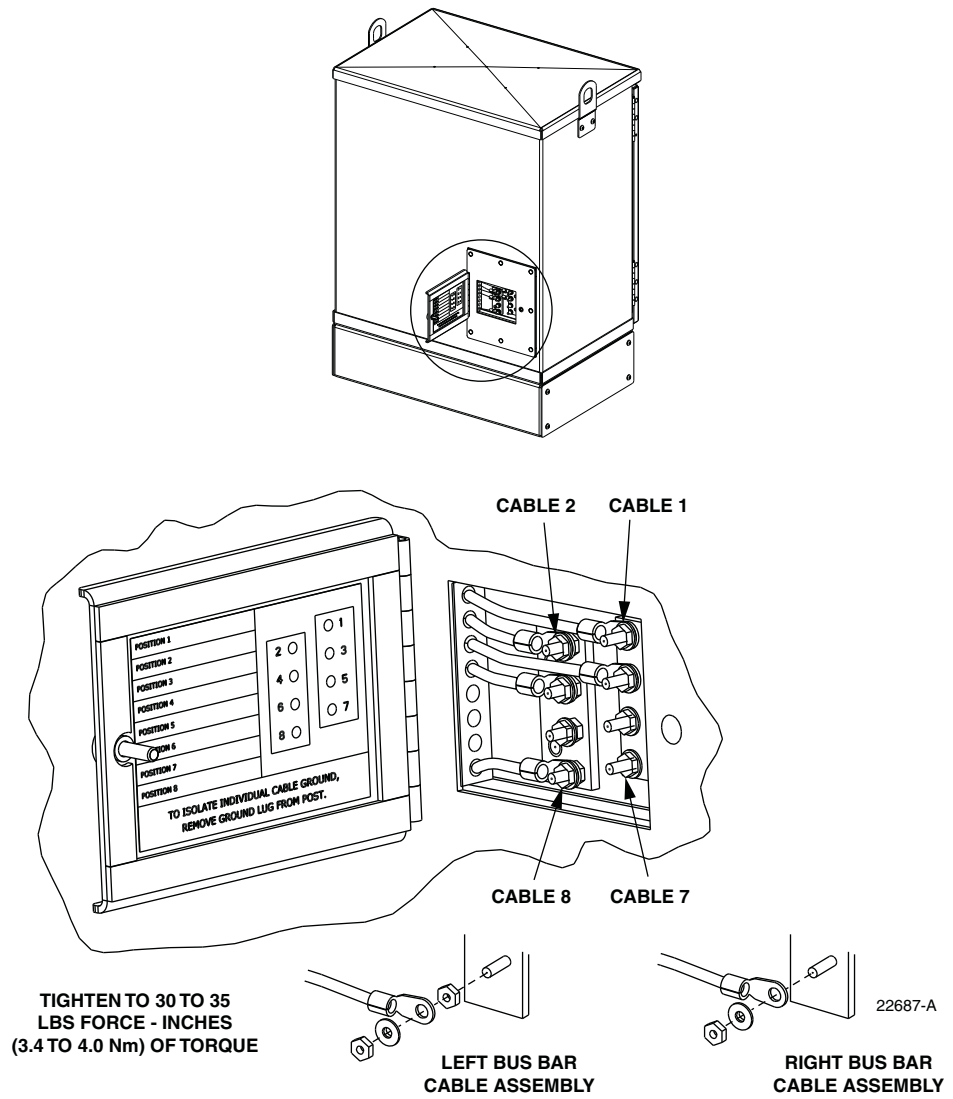

Figure 52. Grounding Block Access Cover

11 CUSTOMER INFORMATION AND ASSISTANCE

To find out more about CommScope® products, visit us on the web at www.commscope.com/

For technical assistance, customer service, or to report any missing/damaged parts, visit us at <http://www.commscope.com/SupportCenter>

