

MATERIAL ID	DESCRIPTION
760237951	SL-AC-BLK

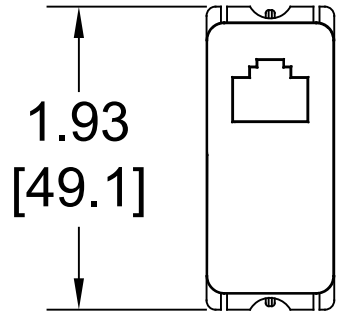

NOTES:

1. SEE COMMSCOPE CATALOG FOR PART NUMBER SUFFIXES TO INDICATE COLOR/PKG.
2. SEE COMMSCOPE CATALOG FOR COMPLETE LIST OF PARTS RELATED TO THE USE OF THIS PRODUCT.
3. DIMENSIONS ARE IN INCHES[MM].
4. PART INCLUDES:  
(4) SL ADAPTER CRADLE, BLACK

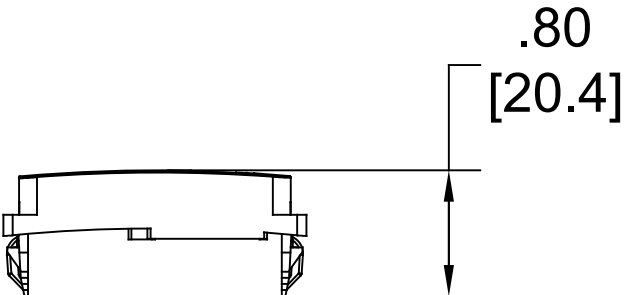
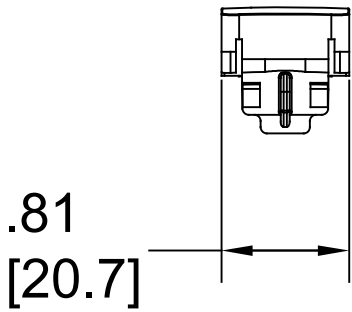

SL ADAPTER CRADLE, BLACK KIT	
<b>COMMSCOPE, INC</b> OF NORTH CAROLINA	

REV	DATE	ECR	DESCRIPTION	APPROVED BY	DATE	DWG NO
1	14-AUG-17		INITIAL ISSUE	AW	14-AUG-2017	760237951