

REV	MCO	DWN	DATE
C	20245376	LS	29-JUL-08
D	BNS_CD_BRAND	GG	10-FEB-17

NOTES:

1.0 SCOPE

THIS SPECIFICATION DEFINES THE REQUIREMENTS FOR A WALL PLATE MODULAR 12 PORT ASSY VARIOUS COLORS

2.0 APPLICABLE DOCUMENTS

- 2.1 UL 94 "TESTS FOR FLAMMABILITY OF PLASTIC MATERIALS"
- 2.2 ORDER OF PRECEDENCE

IN CASE OF CONFLICT, THE FOLLOWING ORDER OF PRECEDENCE SHALL APPLY:
 A. PURCHASE ORDER
 B. THIS DOCUMENT

3.0 REQUIREMENTS

- 3.1 MATERIALS
 - 3.1.1 MATERIAL: ABS POLYLAC PA-765A OR EQUIVALENT.
 - 3.1.2 COLOR: SEE TAB
- 3.2 DIMENSIONAL
 - 3.2.1 SEE DRAWING
 - 3.2.2 PART TO BE FREE OF BURRS, SCRATCHES, SPOTS AND NOTICEABLE SINK.
- 3.3 FLAMMABILITY:
 - 3.3.1 FLAMMABILITY RATING: MATERIAL USED SHALL BE UL94 V-0 LISTED.
- 3.4 MARKING AND MOLDING:
 - 3.4.1 CLASSIFIED U.S. UL LOGO, CLASSIFIED CANADA UL LOGO, UP ARROW DIRECTION, CATALOG NUMBER AND ADC LOGO, SHOULD BE MOLDED INSIDE THE FACE PLATE.

4.0 QUALITY ASSURANCE PROVISIONS:

- 4.1 MANUFACTURING INSPECTION:
THE MANUFACTURER SHALL PERFORM AUDITS TO ENSURE 100% FUNCTIONALITY OF ALL RECEIVED PARTS. ADDITIONAL TESTING AND INSPECTIONS SHALL BE PERFORMED AS NEEDED TO ENSURE THAT ALL REQUIREMENTS ARE MET.
- 4.2 QUALITY CONFORMANCE INSPECTION
BUYER RESERVES THE RIGHT TO RETURN AT THE MANUFACTURER'S EXPENSE ANY NONCONFORMING MATERIALS OR LOTS WHICH DO NOT MEET SAMPLING INSPECTION REQUIREMENTS.
- 4.3 DESIGN AND PROCESS CHANGE:
NO CHANGES IN MATERIAL DESIGN OR PROCESS WHICH WILL AFFECT FORM, FIT OR FUNCTION SHALL BE MADE BY THE MANUFACTURER AFTER SAMPLE APPROVAL WITHOUT WRITTEN AUTHORITY FROM THE BUYER. THE TERM "FUNCTIONAL" IMPLIES SECTION 3.0 PARAMETERS.

5.0 PACKAGING AND HANDLING REQUIREMENTS:

- 5.1 MAXIMUM CONTAINER WEIGHT: 40 LBS.
- 5.2 SHIPPING CONTAINER MARKING(S)

SHIPPING CONTAINERS SHALL BE MARKED WITH THE FOLLOWING AS A MINIMUM:

- 1. MANUFACTURER'S NAME AND/OR LOGO
- 2. ADC PART NUMBER
- 3. ADC PURCHASE ORDER NUMBER
- 4. QUANTITY ENCLOSED
- 5. (PREFERRED BUT OPTIONAL INFORMATION):
NUMBER OF SEPARATE PACKAGES/BOXES
("BOX# ---- OF ---- BOXES")

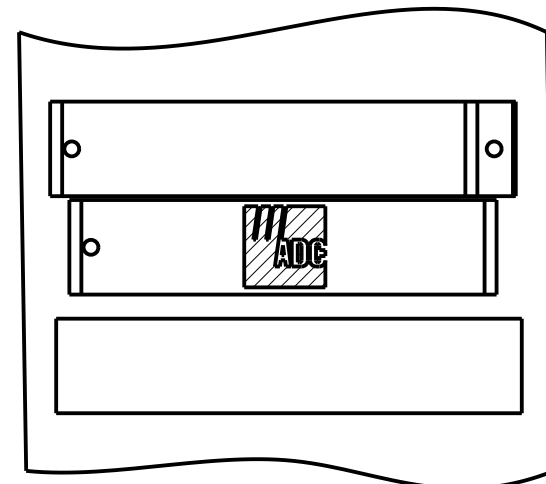

F/N 005 DETAIL

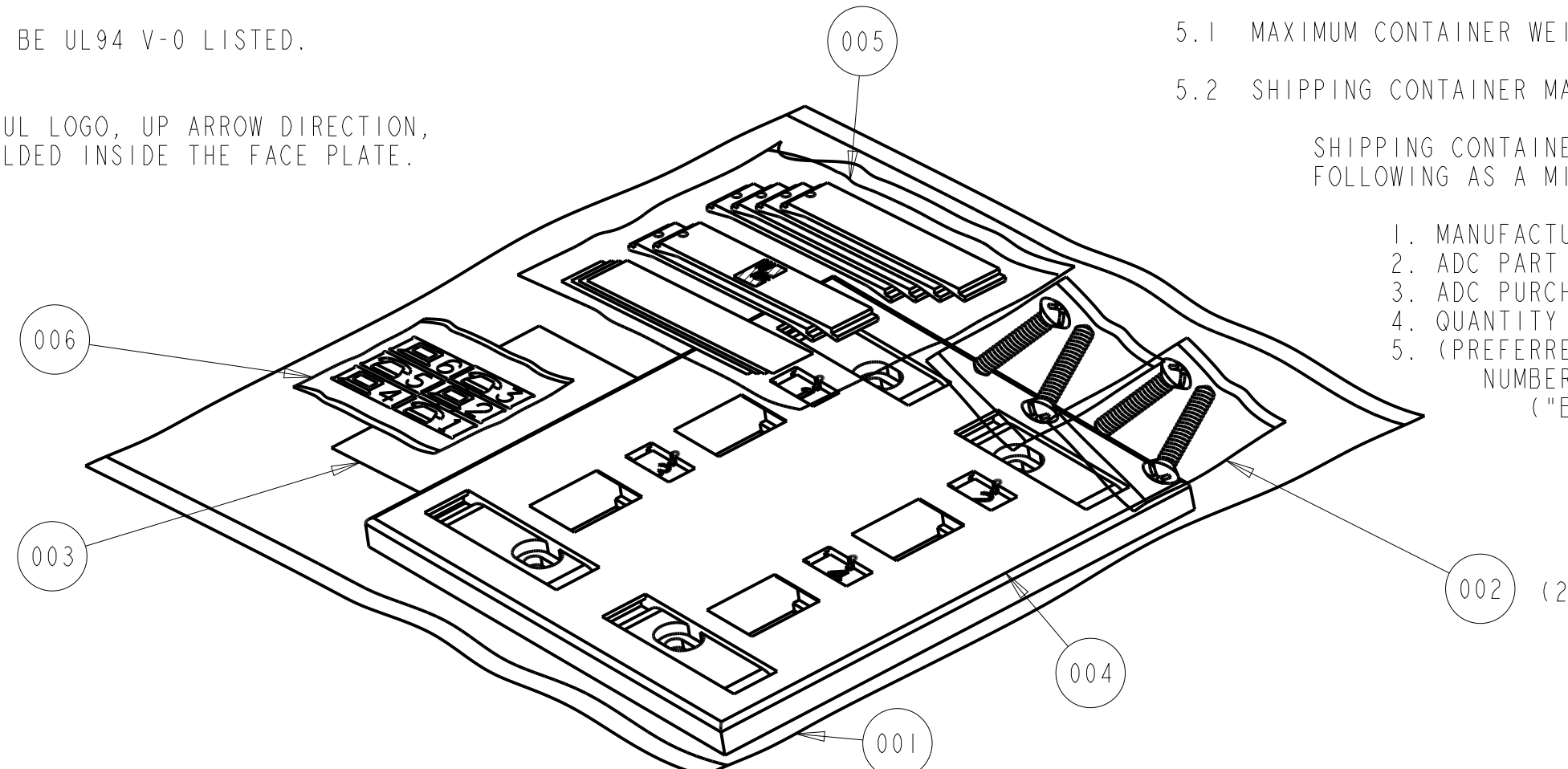

ADC P/N	CATALOG	REV	COMPONENT F/N 001 (DESCRIPTION) QTY 1	COMPONENT F/N 002 (DESCRIPTION) QTY 2	COMPONENT F/N 003 INST SHT 12 PORT WALL PLATE (COLOR) QTY 1	COMPONENT F/N 004 WALL PLATE, MODULAR 12 PORT (COLOR) QTY 1	PANTONE COLOR	FEDERAL STANDAR SPECIFICATION	COMPONENT F/N 005 POLYBAG DESIGNATION (COLOR) QTY 1	COMPONENT F/N 006 POLYBAG #1-6 ID TABS (COLOR) QTY 1
6644116401	6644 I 164-01	B	PA111 0212 00 00 POLYBAG CLEAR 4X7 IN. .002 THICK	6630 3 105-00 POLYBAG W/2 #6 - 32x15/16 COMBO SCREWS	1436364	6644 3 158-01 (WHITE)	---	FED STD. 37925	6630 2 101-01 (WHITE)	6630 2 103-01 (WHITE)
6644116402	6644 I 164-02	B				6644 3 158-02 (IVORY)	---	FED STD. 27886	6630 2 101-02 (IVORY)	6630 2 103-02 (IVORY)
6644116403	6644 I 164-03	B				6644 3 158-03 (GRAY)	421C	FED STD. 25630	6630 2 101-03 (GRAY)	6630 2 103-03 (GRAY)
6644116404	6644 I 164-04	B				6644 3 158-04 (BLACK)	6C2X	FED STD 27038	6630 2 101-04 (BLACK)	6630 2 103-04 (BLACK)
6644116422	6644 I 164-22	B				6644 3 158-22 (ELECTRIC IVORY)	4545U	---	6630 2 101-22 (ELECTRIC IVORY)	6630 2 103-22 (ELECTRIC IVORY)

NOTES:

- 1. ALL POLYBAG IT SHOULD BE SEALED AT BOTH ENDS.

COMMSCOPE, INC.

© 2016 COMMSCOPE, INC. CONFIDENTIAL NOTICE: THESE DRAWINGS AND SPECIFICATIONS ARE THE PROPRIETARY PROPERTY OF COMMSCOPE, INC. AND MAY BE USED ONLY FOR THE SPECIFIC PURPOSE AUTHORIZED IN WRITING BY COMMSCOPE, INC.		TITLE ASSY WALL PLATE DUAL GANG MODULAR 4 PORT	
ALL DIMS AND TOLERANCES ARE INCHES UNLESS OTHERWISE SPECIFIED	.XX:±N/A .XXX:±N/A ANGULAR:±N/A	C SIZE	DRAWING NUMBER 66441164XX_ADC
DO NOT SCALE DRAWING	ENGR: DAVID OWENS DWN: DAVID OWENS	SHT. 1 OF 1	D REV

DIMENSIONS IN INCHES
THIRD ANGLE PROJECTION