

REV	MCO	DWN	DATE
D	20244827	LS	22-JUL-08
E	BNS_CD_BRAND	GG	10-FEB-17

NOTES:

1.0 SCOPE

THIS SPECIFICATION DEFINES THE REQUIREMENTS FOR A WALL PLATE MODULAR 6 PORT ASSY VARIOUS COLORS

2.0 APPLICABLE DOCUMENTS

- 2.1 UL 94 "TESTS FOR FLAMMABILITY OF PLASTIC MATERIALS"
- 2.2 ORDER OF PRECEDENCE

IN CASE OF CONFLICT, THE FOLLOWING ORDER OF PRECEDENCE SHALL APPLY:

- A. PURCHASE ORDER
- B. THIS DOCUMENT

3.0 REQUIREMENTS

- 3.1 MATERIALS
 - 3.1.1 MATERIAL: ABS POLYLAC PA-765A OR EQUIVALENT.
 - 3.1.2 COLOR: SEE TAB
- 3.2 DIMENSIONAL
 - 3.2.1 SEE DRAWING
 - 3.2.2 PART TO BE FREE OF BURRS, SCRATCHES, SPOTS AND NOTICEABLE SINK.
- 3.3 FLAMMABILITY:
 - 3.3.1 FLAMMABILITY RATING: MATERIAL USED SHALL BE UL94 V-0 LISTED.
- 3.4 MARKING AND MOLDING:
 - 3.4.1 CLASSIFIED U.S. UL LOGO, CLASSIFIED CANADA UL LOGO, UP ARROW DIRECTION, CATALOG NUMBER AND ADC LOGO, SHOULD BE MOLDED INSIDE THE FACE PLATE.

4.0 QUALITY ASSURANCE PROVISIONS:

- 4.1 MANUFACTURING INSPECTION: THE MANUFACTURER SHALL PREFORM AUDITS TO ENSURE 100% FUNCTIONALITY OF ALL RECEIVED PARTS. ADDITIONAL TESTING AND INSPECTIONS SHALL BE PREFORMED AS NEEDED TO ENSURE THAT ALL REQUIREMENTS ARE MET.
- 4.2 QUALITY CONFORMANCE INSPECTION BUYER RESERVES THE RIGHT TO RETURN AT THE MANUFACTURER'S EXPENSE ANY NONCONFORMING MATERIALS OR LOTS WHICH DO NOT MEET SAMPLING INSPECTION REQUIREMENTS.
- 4.3 DESIGN AND PROCESS CHANGE: NO CHANGES IN MATERIAL DESIGN OR PROCESS WHICH WILL AFFECT FORM, FIT OR FUNCTION SHALL BE MADE BY THE MANUFACTURER AFTER SAMPLE APPROVAL WITHOUT WRITTEN AUTHORITY FORM THE BUYER. THE TERM "FUNCTIONAL" IMPLIES SECTION 3.0 PARAMETERS.

5.0 PACKAGING AND HANDLING REQUIREMENTS:

- 5.1 MAXIMUM CONTAINER WEIGHT: 40 LBS.
- 5.2 SHIPPING CONTAINER MARKING(S)

SHIPPING CONTAINERS SHALL BE MARKED WITH THE FOLLOWING AS A MINIMUM:

- 1. MANUFACTURER'S NAME AND/OR LOGO
- 2. ADC PART NUMBER
- 3. ADC PURCHASE ORDER NUMBER
- 4. QUANTITY ENCLOSED
- 5. (PREFERRED BUT OPTIONAL INFORMATION): NUMBER OF SEPARATE PACKAGES/BOXES ("BOX# ---- OF ---- BOXES")

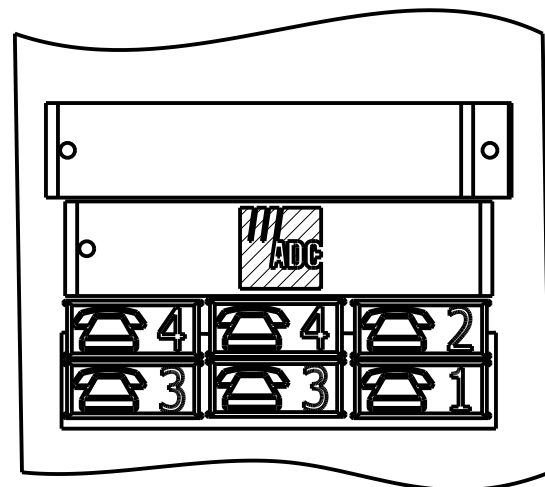

F/N 005 DETAIL

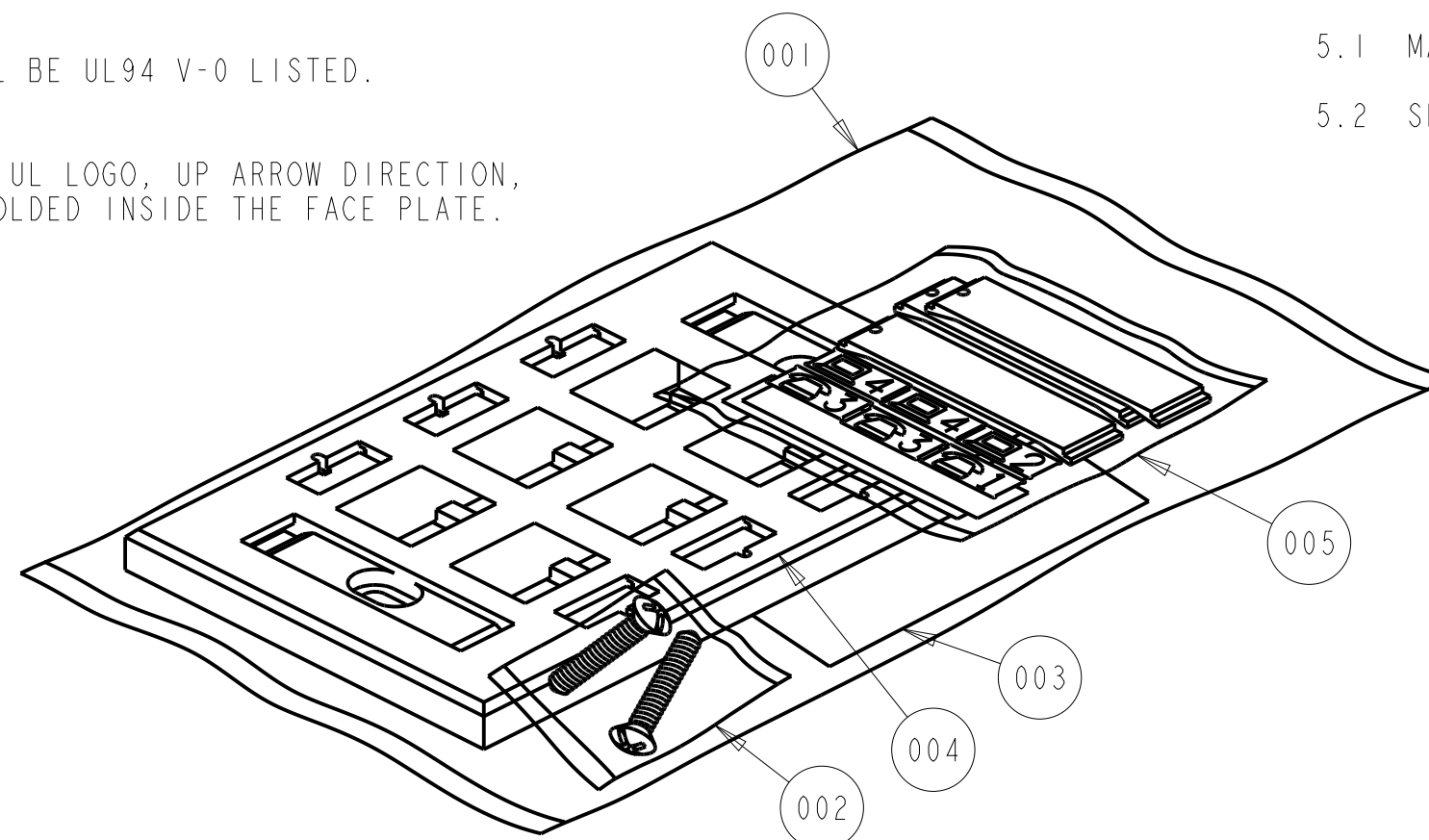

ADC P/N	CATALOG	REV	COMPONENT F/N 001 (DESCRIPTION) QTY 1	COMPONENT F/N 002 (DESCRIPTION) QTY 1	COMPONENT F/N 003 INST SHT 6 PORT WALL PLATE (COLOR) QTY 1	COMPONENT F/N 004 WALL PLATE, MODULAR 6 PORT (COLOR) QTY 1	PANTONE COLOR	FEDERAL STANDAR SPECIFICATION	COMPONENT F/N 005 POLYBAG ID TABS & DESIGNATION (COLOR) QTY 1
6644115601	6644 1 156-01	B	PA111 0212 00 00 POLYBAG CLEAR 4X7 IN. .002 THICK	6630 3 105-00 POLYBAG W/2 #6 - 32x15/16 COMBO SCREWS	1436364	6644 3 156-01 (WHITE)	---	FED STD. 37925	6630 3 116-01 (WHITE)
6644115602	6644 1 156-02	B				6644 3 156-02 (IVORY)	---	FED STD. 27886	6630 3 116-02 (IVORY)
6644115603	6644 1 156-03	B				6644 3 156-03 (GRAY)	421C	FED STD. 25630	6630 3 116-03 (GRAY)
6644115604	6644 1 156-04	B				6644 3 156-04 (BLACK)	6C2X	FED STD 27038	6630 3 116-04 (BLACK)
6644115613	6644 1 156-13	B				6644 3 156-13 (GRAPHITE)	---	---	6630 3 116-13 (GRAPHITE)
6644115622	6644 1 156-22	B				6644 3 156-22 (ELECTRIC IVORY)	4545U	---	6630 3 116-22 (ELECTRIC IVORY)

NOTES:

- 1. ALL POLYBAG IT SHOULD BE SEALED AT BOTH ENDS.

COMMSCOPE, INC.

© 2016 COMMSCOPE, INC. CONFIDENTIAL
NOTICE: THESE DRAWINGS AND SPECIFICATIONS ARE THE PROPRIETARY PROPERTY OF COMMSCOPE, INC. AND MAY BE USED ONLY FOR THE SPECIFIC PURPOSE AUTHORIZED IN WRITING BY COMMSCOPE, INC.

ALL DIMS AND TOLERANCES .XX:±xx
ARE INCHES UNLESS .XXX:±xxx
OTHERWISE SPECIFIED ANGULAR:±N/A

DO NOT SCALE DRAWING

LUIS SANCHEZ
DWN: JUAN MONCADA

TITLE ASSY WALL PLATE MODULAR 6 PORT

DRAWING NUMBER 66441156XX_ADC

SHT. 1 OF 1

DIMENSIONS IN INCHES
THIRD ANGLE PROJECTION