

ITEM NO.	DESCRIPTION	QTY
1	BOLT, 3/8 in.-16 X 7/8 in.	12
2	NUT, Flange, 3/8 in.-16	12
3	SCREW, Equipment, 12-24	30
4	NUT, Crown, 1/4 in.-20	20
5	SCREW, 1/4 in.-20	20
6	D-RING	14
7	SPACER, Top Angle	2
8	DIVIDER, Top Angle	1
9	ANGLE, Top Front	1
10	ANGLE, Top Rear	1
11	ANGLE, Bottom	2
12	UPRIGHT	2

Figure 1

1. INTRODUCTION

This instruction sheet provides assembly instructions for the Two-Post Cable Management Rack 1933560-1. These instructions should be read thoroughly before starting the assembly process.

Component parts required to assembly the Two-Post Cable Management Rack are shown in Figure 1.



NOTE

All dimensions on this document are in metric units with [U.S. customary units in brackets]. Figures and illustrations are for identification only and are not drawn to scale.

To obtain information on CommScope products, visit the CommScope website at www.CommScope.com



To reduce risk of injury, or damage to equipment, the rack must be properly secured to the floor.



To reduce risk of injury, or damage to equipment, do NOT install equipment in the rack until properly secured to the floor.

2. ASSEMBLY INSTRUCTIONS

1. Lay the uprights on a flat surface as shown in Figure 2.
2. Place the bottom angle on uprights aligning holes for specific panel mounting width.
3. Fasten bottom angle to upright using four (4) 3/8 in.-16 x 7/8 in. hex head cap screw and flange nuts. *Finger tighten.* See Figure 2.

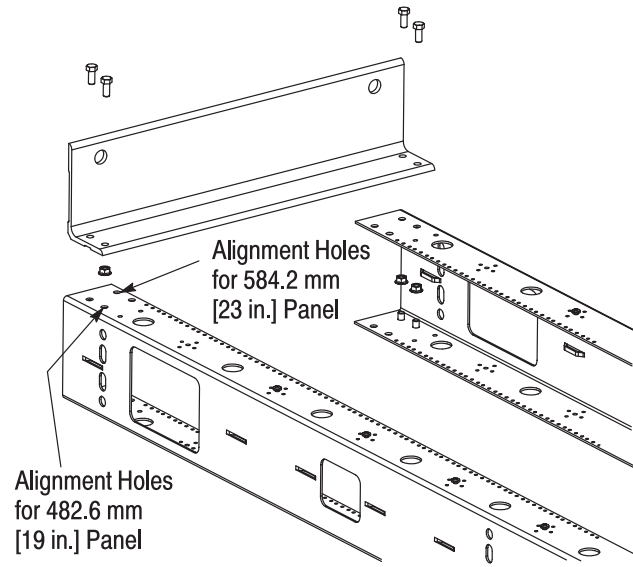

Figure 2

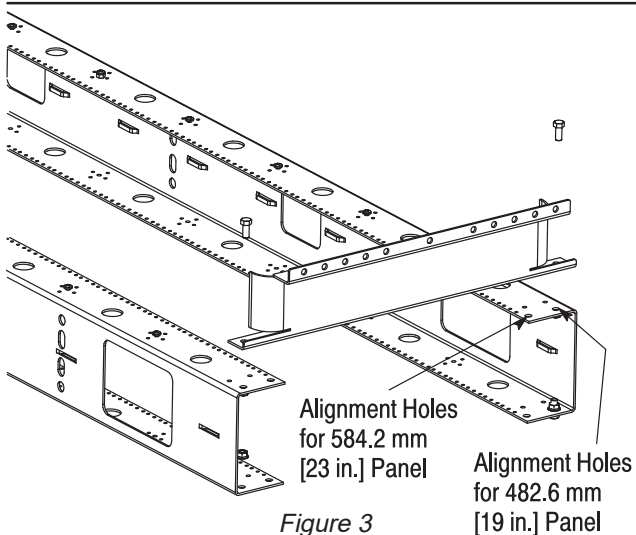

Figure 3

4. Place front top angle on uprights aligning holes for specific panel mounting width.
5. Fasten front top angle to upright using four (2) 3/8 in.-16 x 7/8 in. hex head cap screw and flange nuts. *Finger tighten.* See Figure 3.
6. Turn rack over.
7. Place bottom angle on uprights aligning holes for specific panel mounting width.
8. Fasten bottom angle to upright using four (4) 3/8 in.-16 x 7/8 in. hex head cap screw and flange nuts. *Finger tighten.* See Figure 2.
9. Place rear top angle on uprights aligning holes for specific panel mounting width.
10. Fasten rear top angle to upright using four (2) 3/8 in.-16 x 7/8 in. hex head cap screw and flange nuts. *Finger tighten.* See Figure 3.
11. Stand rack up, square uprights, and tighten all fasteners to 27.12 Nm [20 ft.-lbs.]. See Figure 4.

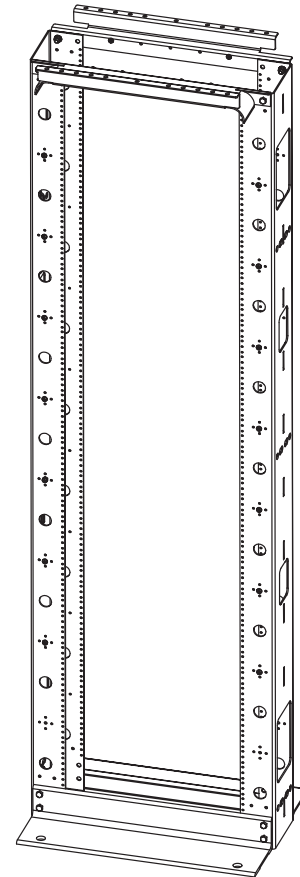

Figure 4

12. Install top angle spacers and divider with 1/4 in. screws and crown nuts. See Figure 5A and 5B.

13. Install “D”-Rings with 1/4 in. screws and crown nuts in front or rear of uprights. See Figures 5A and 5B.

14. Place rack in desired location and mount to floor securely before installing equipment. See Figure 6.

3. REVISION SUMMARY

- Initial release of document
- Rebranded to CommScope

5A (Front View)

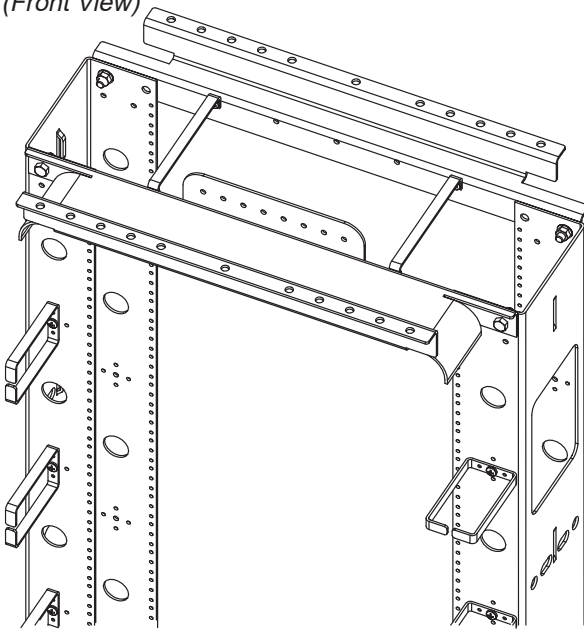

5B (Rear View)

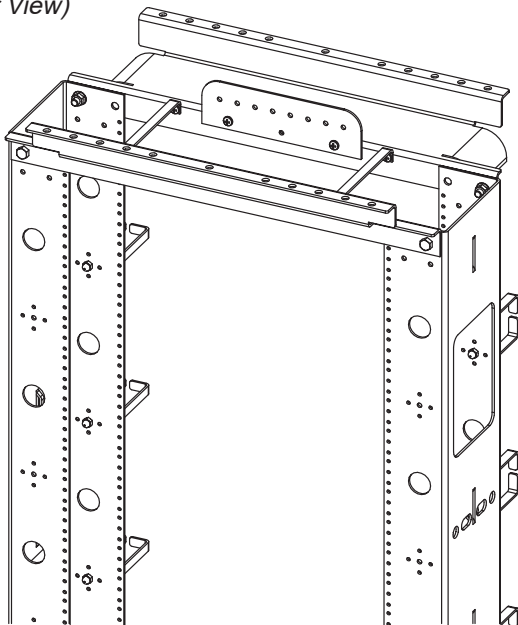

Figure 5

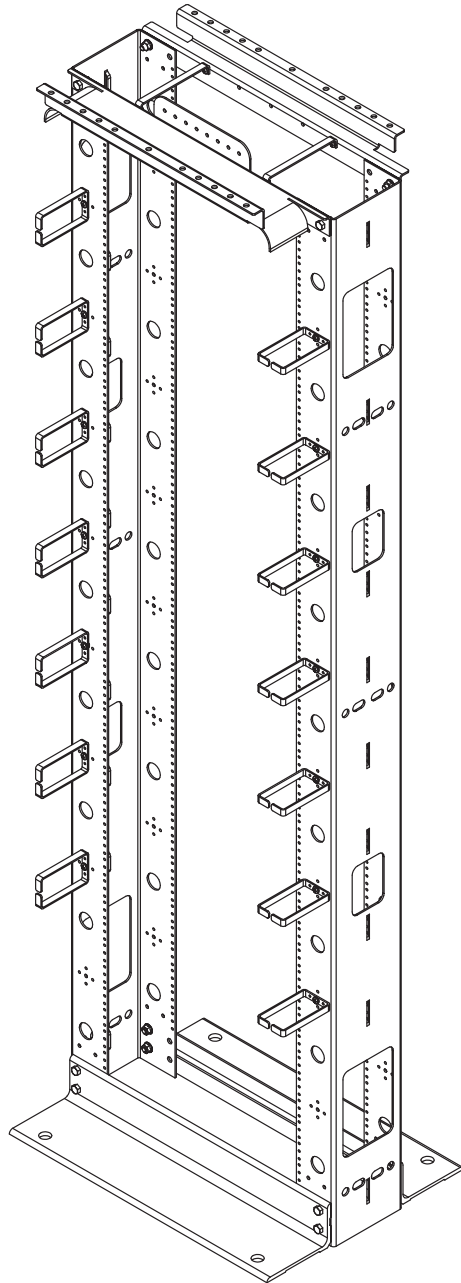

Figure 6