

Connectors for HELIAX® HJ9-50 Coaxial Cable



Tools and Materials Required for Assembly

- Knife
- Flat file
- Metal snips
- Plastic head mallet
- Hacksaw: fine-toothed blade
- Wrenches: (2) 1-1/16", (1)9/16"
- Plastic rod, 5/8" (11 mm) diameter
- Miter box
- Pliers
- Screwdriver
- Mallet, nylon or plastic head

Notice

The installation, maintenance or removal of antenna systems requires qualified, experienced personnel. Andrew installation instructions are written for such personnel. Antenna systems should be inspected once a year by qualified personnel to verify proper installation, maintenance and condition of equipment.

Andrew disclaims any liability or responsibility for the results of improper or unsafe installation practices.

1 Prepare Cable. Prepare both cables using the instructions in steps 1 through 7. The cable must be straight for at least 18 inches (457 mm) and the end must be square. If the end is not square, use a miter box and hacksaw to make a new cut. Use a straight-edged piece of heavy paper wrapped around the cable to guide the jacketing cut. Cut the jacket with a sharp knife. File the cut edges of both the inner and outer conductors to remove the burrs. Use a knife to deburr the inside edges of the conductors. Hold the cable end downward and tap the end to shake out any copper particles that may have entered.

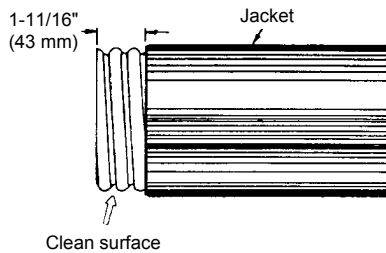

2 Install Outer Body, Captivated Ring, Gasket, and Clamping Ring. Apply a thin coating of silicone grease to the inside surface of the large rubber gasket and to the gasket mating inside surface of the outer body for easier assembly. Slip the outer body over the cable with the flange toward the prepared cable end. Screw the gasket onto the cable until the captivated ring is against the jacket. Install the clamping ring until it is against the gasket. The gasket and clamping ring should be pressed toward the jacket as far as possible in order to permit a proper cutting operation.

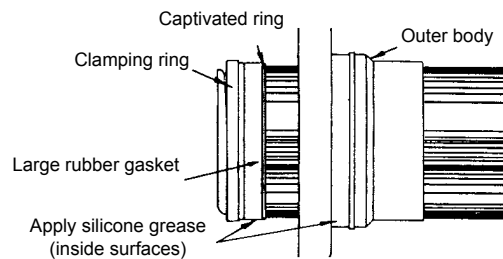

3 Cut Tabs in Outer Conductor. Cut tabs with metal snips into the outer conductor to the depth and intervals shown.

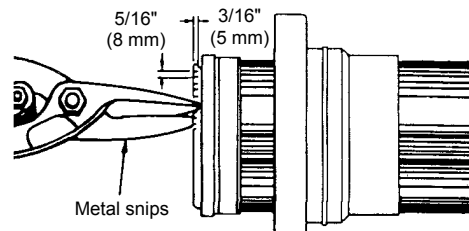

4 Flare Outer Conductor. Screw the clamping ring back from the gasket to the dimension shown. Screw the gasket against the clamping ring. Flare the outer conductor against the edge of the clamping ring using a rod with a rounded end and a mallet. Carefully tap the outer conductor flat against the clamping ring using the mallet alone. Trim any portion of the outer conductor that protrudes beyond the outside diameter of the clamping ring. See the end view of the outer conductor tabs. Remove any rough spots with a file. Cut the dielectric material flush with the flared tabs.

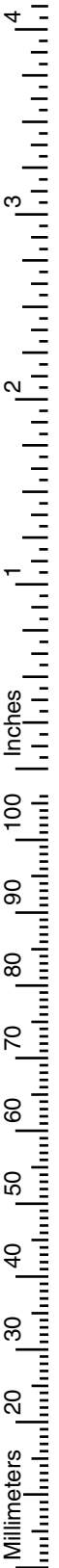
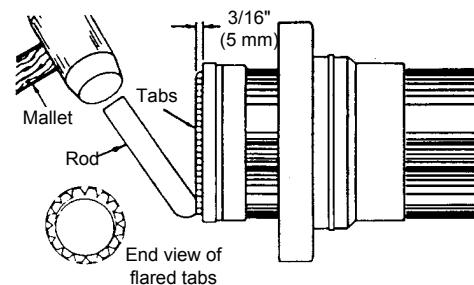

5 Install Inner Stub. Screw the inner stub deep into the inner conductor as shown. The inner stub has a screwdriver slot to facilitate its insertion into the inner conductor. The inner stub must be deep enough to clear the metal snips when notches are cut into the inner conductor.

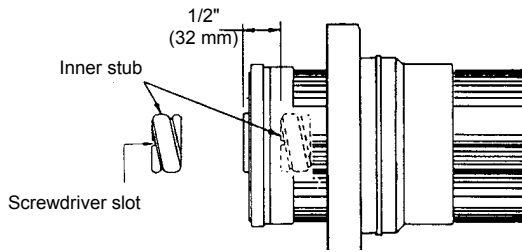

6 Notch Inner Conductor. Cut approximately twelve 45-degree V-notches into the inner conductor to the depth shown.

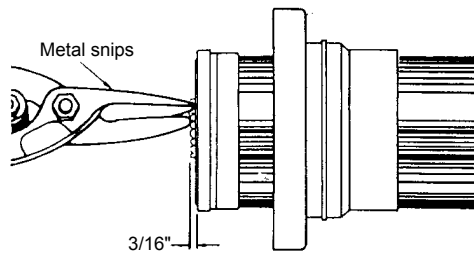

7 Secure Inner Stub. Back the inner stub out of the inner conductor to the dimension shown. The tabs that lie over the screwdriver slot must be tapped into the slot. This will secure the inner stub and prevent it from turning when the remaining parts are installed. Use a screwdriver to bend the cut tabs over the end of the inner stub. Tap the tabs into place with a rod and mallet. See the end view of the inner conductor tabs. Do not overlap the tabs.

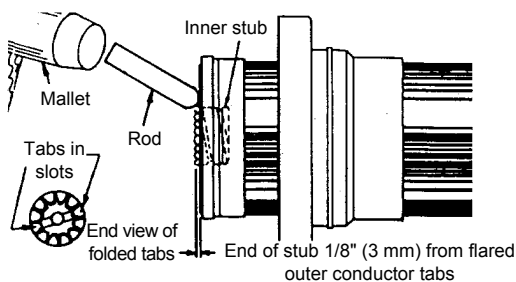

8 Install Stud. Screw the stud two turns into the inner stub on one cable. If the threads do not engage, turn the stud end-for-end and repeat. Be careful not to cross the threads. Apply a thin coating of silicone grease all around the O-ring. Place the O-ring temporarily in the position shown.

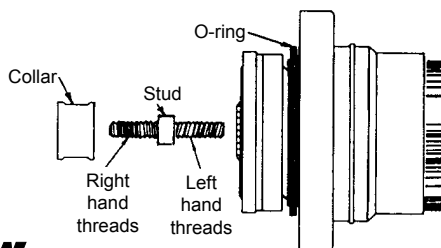

9 Connect Cable Ends With Stud. Slide the collar onto the center of the stud engaging the square cutout in the collar with the center square section of the stud. Align the processed ends of both cables and turn the collar so that the stud screws into both cables at the same time. Use a wrench and continue turning until the collar is firmly against the tabs on each inner conductor.

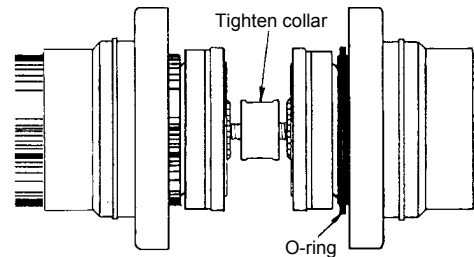

10 Install Spacer Halves. Install the spacer halves between the flared outer conductors as shown. The spacers, when installed, are separated by a factory pre-set alignment pin on each spacer to maintain the proper diameter. Apply silicone grease to the outside surface of the large rubber gasket.

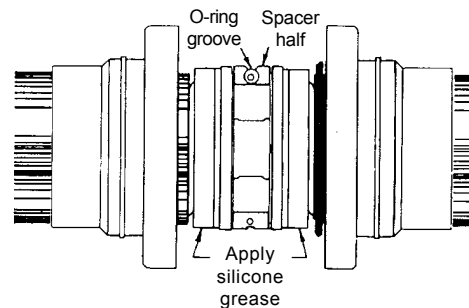

11 Clamp Outer Bodies Together. Move the O-ring from its temporary position into the groove in the mated spacer halves as shown. Pull the outer bodies together using three 4" long temporary bolts and nuts installed 120° apart. Do not twist the outer bodies. When the mating flanges are close enough together to use the 2-1/2" long bolts, install the shorter bolts, nuts, and lock washers in the remaining three holes. Then remove the longer bolts and replace them with the three remaining 2-1/2" bolts, nuts and lock washers and tighten all nuts evenly. The gap between the flanges must be uniform throughout the circumference.



Andrew Corporation
10500 West 153rd Street
Orland Park, IL U.S.A. 60462

Telephone: 708-349-3300
FAX (U.S.A.): 1-800-349-5444
Internet: <http://www.andrew.com>

Customer Service, 24 hours: U.S.A. • Canada • Mexico: 1-800-255-1479
U.K.: 0800 250055 • Republic of Ireland: 1 800 535358
Other Europe: +44 1592 782612
Printed in U.S.A. 9/97
Copyright © 1997 by Andrew Corporation