

APTDC-MBDFDF-DB

Arrestor Plus® Dual Band Quarterwave dc Passing Surge Arrestor (T-shaped), 698–960 MHz and 1700–2170 MHz, with interface types DIN Female Bulkhead and DIN Female

OBSOLETE

Product Classification

Product Type	Surge arrestor
Product Brand	Arrestor Plus®
Ordering Note	CommScope® non-standard product

General Specifications

Device Type	dc Pass
Body Style	Bulkhead
Inner Contact Plating	Silver
Interface	7-16 DIN Female Bulkhead
Interface 2	7-16 DIN Female
Outer Contact Plating	Trimetal
Pressurizable	No

Dimensions

Height	81 mm 3.189 in
Width	42 mm 1.654 in
Length	88 mm 3.465 in

Outline Drawing

APTDC-MBDFDF-DB

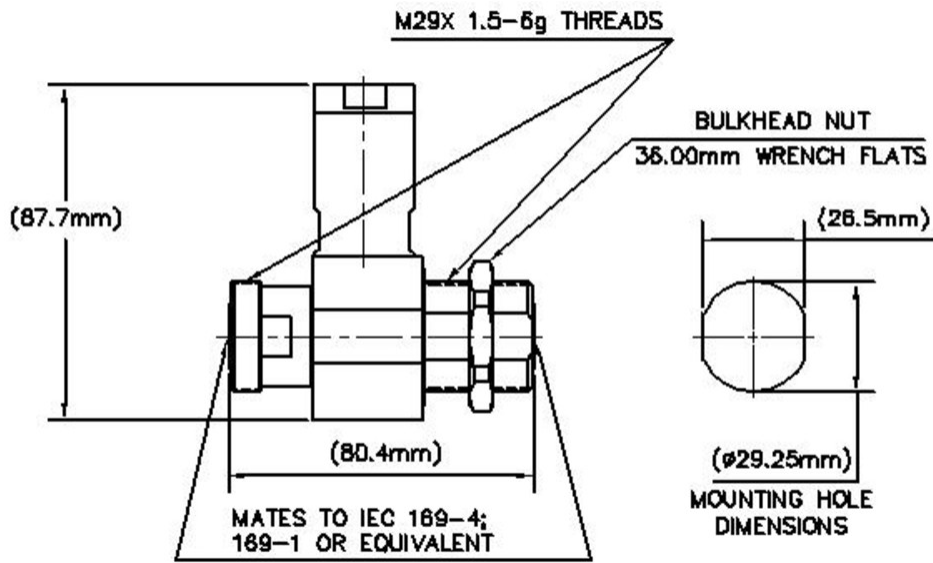

Electrical Specifications

3rd Order IMD	-117 dBm
3rd Order IMD Test Method	Two +43 dBm carriers
Insertion Loss, typical	0.05 dB
Average Power	3000 W
Connector Impedance	50 ohm
Gas Tube Voltage	350 V
Lightning Surge Capability	10 times @ 30 kA
Lightning Surge Capability Test Method	IEEE C62.42-1991
Lightning Surge Capability Waveform	8/20 waveform
Lightning Surge Current	30 kA
Lightning Surge Current Waveform	8/20 waveform
Operating Frequency Band	1710 – 2170 MHz 698 – 960 MHz
Peak Power, maximum	40 kW

VSWR/Return Loss

Frequency Band	VSWR	Return Loss (dB)
806–960 MHz	1.106	25.96
1710–2000 MHz	1.106	25.96

APTDC-MBDFDF-DB

2000–2170 MHz 1.106 25.96

Mechanical Specifications

Attachment Durability	25 cycles
Interface Durability	500 cycles
Interface Durability Method	IEC 61169-16:9.5
Mechanical Shock Test Method	MIL-STD-202F, Method 213B, Test Condition C

Environmental Specifications

Operating Temperature	-40 °C to +100 °C (-40 °F to +212 °F)
Storage Temperature	-70 °C to +150 °C (-94 °F to +302 °F)
Attenuation, Ambient Temperature	20 °C 68 °F
Average Power, Ambient Temperature	40 °C 104 °F
Corrosion Test Method	MIL-STD-202, Method 101, Test Condition B
Immersion Depth	1 m
Immersion Test Mating	Mated
Immersion Test Method	IEC 60529:2001, IP68
Moisture Resistance Test Method	MIL-STD-202, Method 106
Thermal Shock Test Method	MIL-STD-202, Method 107, Test Condition A-1, Low Temperature -55 °C
Water Jetting Test Mating	Mated

Packaging and Weights

Weight, net 0.64 kg | 1.41 lb

* Footnotes

Insertion Loss, typical	0.05√freq (GHz) (not applicable for elliptical waveguide)
Immersion Depth	Immersion at specified depth for 24 hours