

REVISIONS			
REV	CMO	DATE	APPROVED
B	40194617CMO	25-JUN-2024	GVR
C	40215866CMO	21-MAR-2025	FS

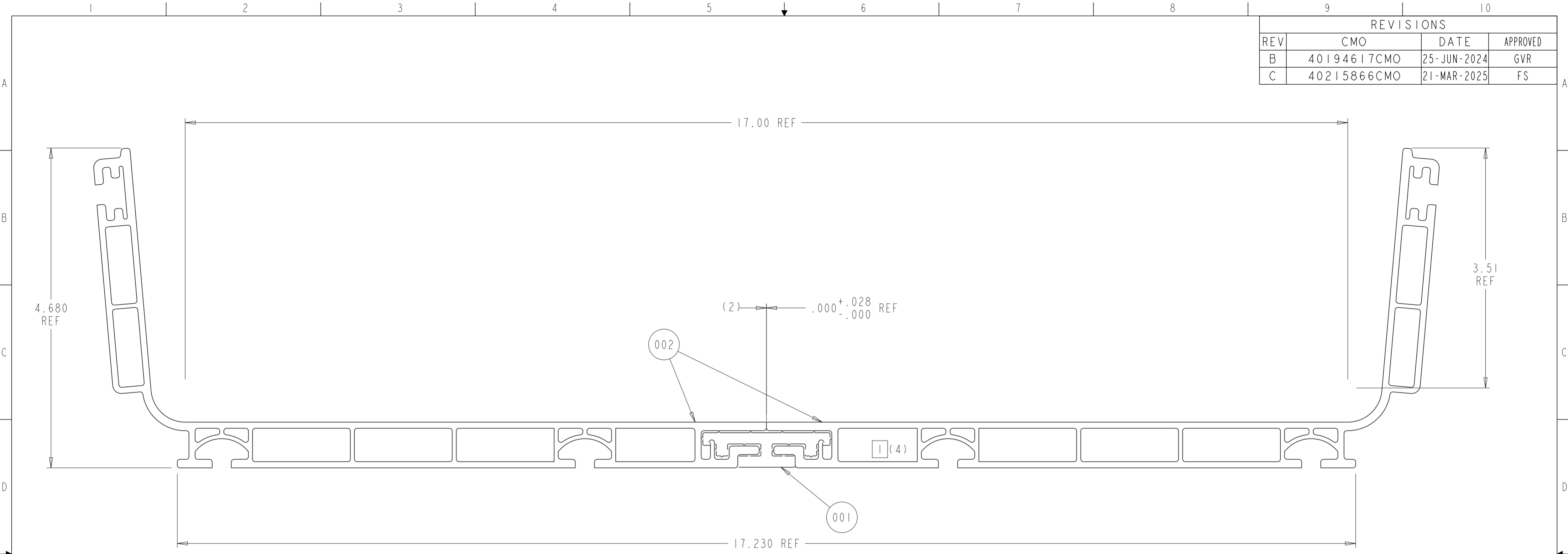

LIST OF ITEMS IN ASSEMBLY		
ITEM	DESCRIPTION	QTY
001	FGS 24" SPLINE	4
002	FGS 18" TROUGH HALF	2
999	INSTALLATION DRAWING	1

NOTES:
 I INSERT ONE OF EACH ITEM 001 INTO ITEM 002 FROM EACH END.

FGSB-MSHS-M12	BLACK	144"
FGS-MSHS-M12	YELLOW	144"
FGSB-MSHS-M10	BLACK	120"
FGS-MSHS-M10	YELLOW	120"
FGSB-MSHS-M	BLACK	72"
FGS-MSHS-M	YELLOW	72"
CATALOG NUMBER	COLOR	DIM"A"

MINIMUM OF 5 POUND OF FORCE IS REQUIRED FOR SEPARATION OF A 12 INCH LONG SECTION

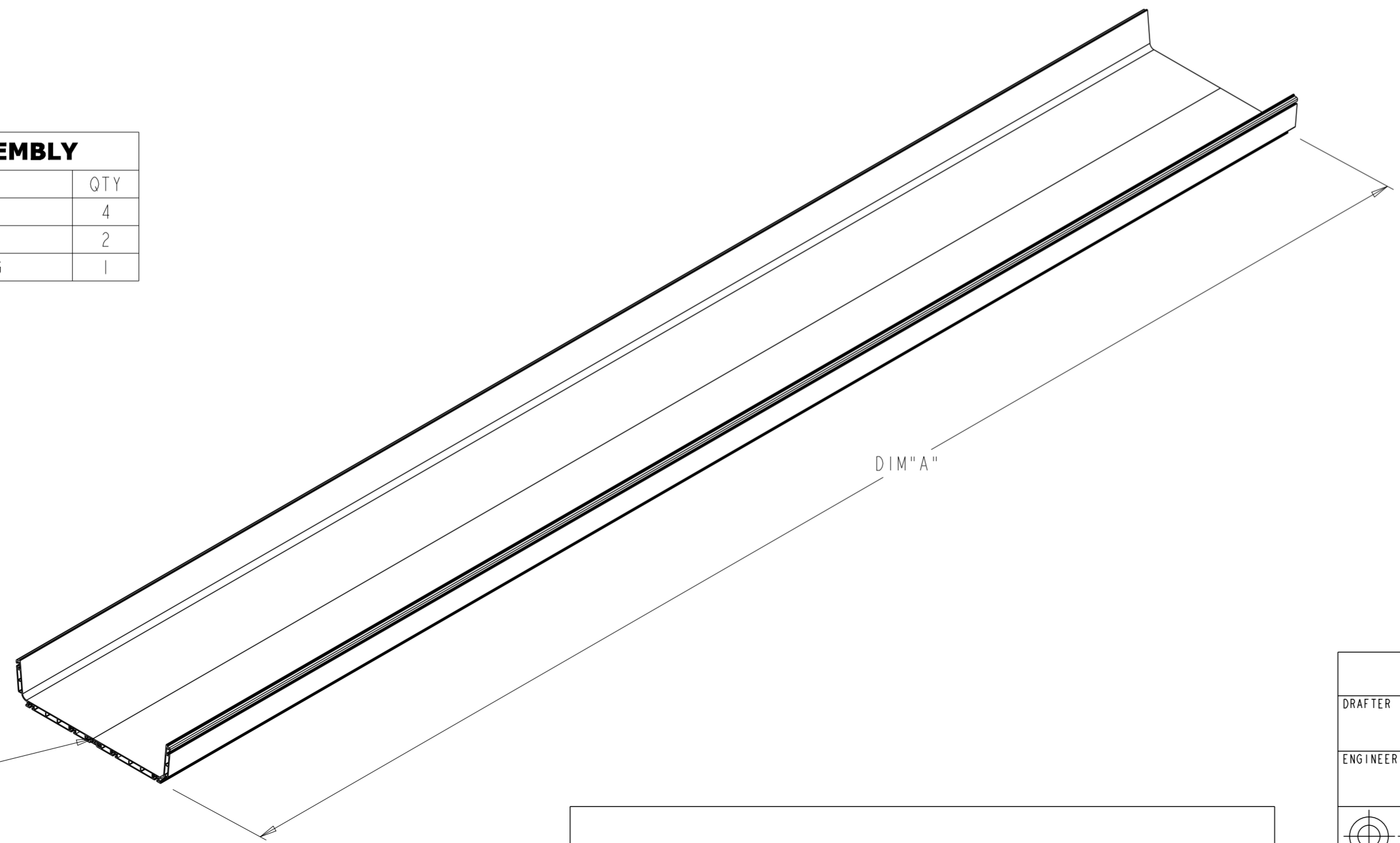

COMMSCOPE, INC.			
DRAFTER RUBEN ARVILLA		TITLE INSTALL DWG, 18X12FT LONG STRAIGHT	
ENGINEER RUBEN ARVILLA		SIZE A2	SCALE 1.100
		DOCUMENT NO. 660001754	
CUSTOMER DRAWING			REVISION C
			SHEET 1 OF 1