

Gel Plug Kit For Sealing up to 4 Small Cables in FOSC 450 & FOSC 600 Closures

1.0 General Product Description

This kit is used to install up to four flat cables, or up to four small round cables or ground wires under .25" outside diameter in one gel port of a FOSC 450 or FOSC 600 splice closure. For round cables over .25" in outside diameter, use the Wrap Style 4 Small Cables Sealing Kit.

NOTE: Do not use a braided or stranded wire when installing a ground through a port on any CommScope fiber optic splice closure. CommScope requires a solid, bonded ground wire to prevent a leak path and create a proper seal.

2.0 Kit Contents

- Black felt tape (a)
- Hose clamp (b)
- Strength member bracket (c)
- Perforated metal square (d)
- Port splitter (e)
- Cable retention bracket assembly (f) -- optional

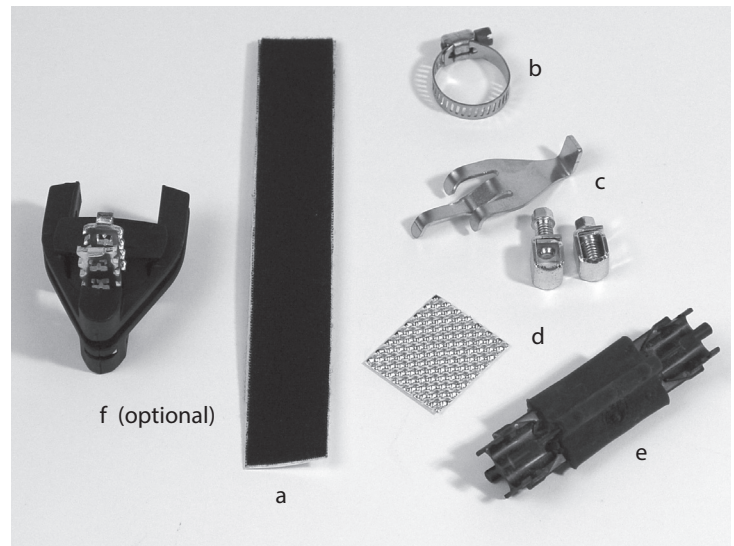

3.0 Installation Instructions

NOTE: If installing a drop with a messenger or tracer wire, separate the wire from the drop cable to remain outside the closure, and shave the area of the drop that goes through the gel seal to create a smooth flat surface.

For Closure Type.....	Refer to Section
FOSC 450 A Closures.....	3.1
FOSC 450 B, BS, C, and D Closures.....	3.2
FOSC 600 Closures.....	3.3

3.1 FOSC 450 A Closures

Note: The 4-drop kit can only be installed in the two large ports of the FOSC 450 A4 closure.

1. Remove 70" of cable sheath from the drop cables.
2. Mark the cable sheath 1.75" from the sheath ring cut. (Figure 1)

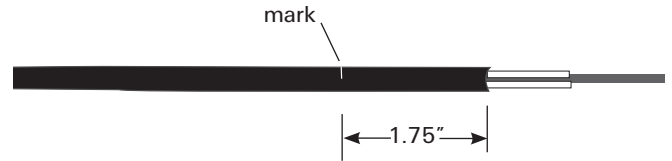

Figure 1

3. Align the end of the port splitter with the 1.75" mark. (Figure 2)
4. If required, insert other cable(s) in any slot of the port splitter. (Figure 2) Align the sheath ring cuts of all cables.

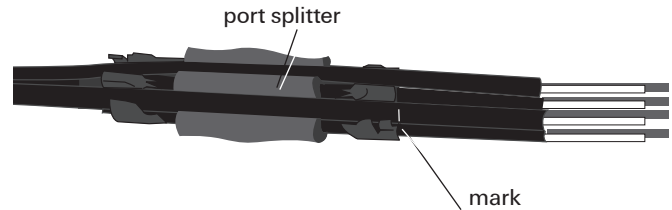

Figure 2

5. For multiple cables, insert the perforated metal square between the cables in the splitter 1/2" from the ring cut, and bundle the cables with vinyl tape on both sides of the port splitter.
6. Wrap two complete layers of black felt tape around cable(s) 1/2" from the ring cut. (Figure 3)
7. Cut each strength member 1.75" from the sheath ring cut.
8. Secure all strength members in the strength member bracket.

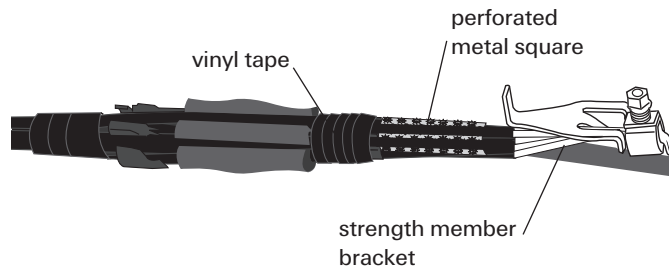
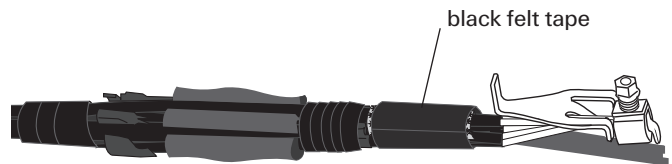

Figure 3

Note: If all strength members will not fit in a single lug, trim the strength members to 1.5" and use the additional lug and the outer forks of the strength member bracket.

9. Insert the cable assembly through the FOSC 450 closure base and position it into either of the large ports.



10. Place the cable between the cable retention bracket teeth and secure the cable with the hose clamp. (Figure 4) Tighten the clamp such that retention bracket teeth seat fully into the black felt cable wrap.
11. Go to Section 4.0.

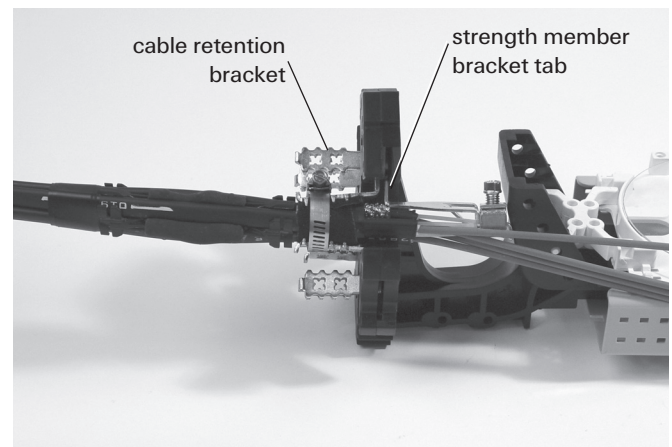

Figure 4

Note: The head of the hose clamp has to be positioned on top of the cable retention bracket. Otherwise it might interfere with the base when assembled.

3.2 FOSC 450 B, BS, C, and D Closures

1. Remove 70" of cable sheath from the end of the drop cables.
2. Mark the cable sheath 2.25" from the sheath ring cut. (Figure 5)

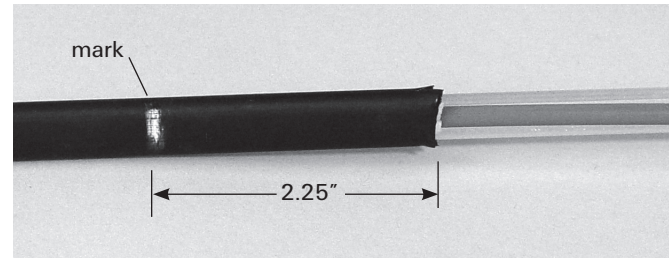

Figure 5

3. Align the end of the port splitter with the 2.25" mark. (Figure 6)
4. If required, insert other cable(s) in any slot of the port splitter. (Figure 6) Align the sheath ring cuts of all cables.

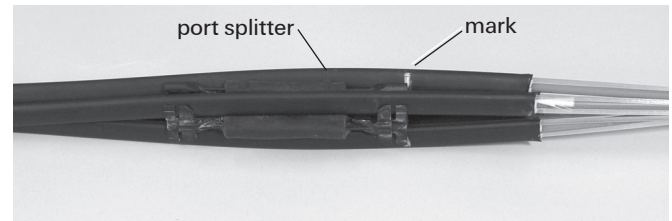

Figure 6

5. For multiple cables, insert perforated metal square between the cables 1/2" from the ring cut, and bundle the cables with vinyl tape on both sides of the port splitter.
6. Wrap two complete layers of black felt tape around cable(s) 1/2" from the ring cut. (Figure 7)
7. Cut the strength members 1.75" from the ring cut.
8. Position the strength member bracket so that the flat surface of the bracket tab is aligned with the flat surface of the cable. Secure all strength members into the strength member bracket.

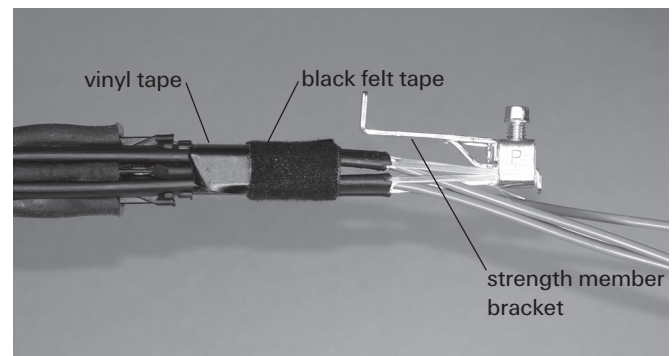

Figure 7

Note: If all strength members will not fit in a single lug, trim the strength members to 1.5" and use the additional lug and the outer forks of the strength member bracket.

9. Position the cable retention bracket assembly so that the strength member bracket tab fits in the slot of the top half of the assembly, and the teeth of the retention clips surround the black felt tape. (Figure 8)
10. Install the hose clamp over the retention clips. Tighten the clamp such that retention bracket teeth seat fully into the black felt cable wrap. (Figure 8)
11. Insert the cable retention bracket assembly through the FOSC 450 closure base and position it into an empty slot on the closure frame.
12. Go to Section 4.0

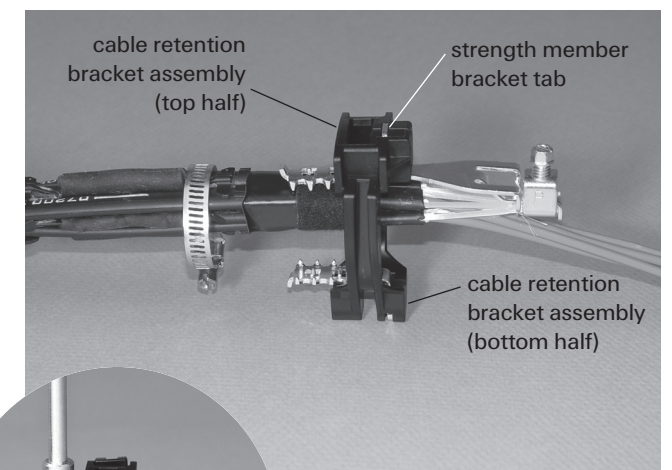
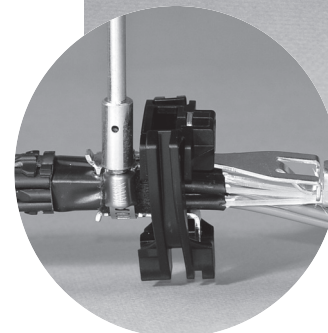

Figure 8



3.3 FOSC 600 Closures

Note: Requires the use of a FOSC 600 small strength member bracket and lugs included in the FOSC 600 closures.

1. Remove 100" of cable sheath from the end of the drop cables.
2. Mark the cable sheath 3.50" from the sheath ring cut. (Figure 9)

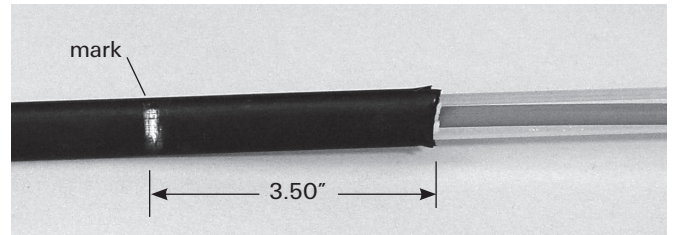

Figure 9

3. Line up the top of the port splitter with the 3.50" mark on the cable sheath. (Figure 10)
4. If required, insert other cable(s) in any slot of the port splitter. (Figure 10)
5. For multiple cables, insert perforated metal square between the cables at the end of the ring cut, and bundle the cables with vinyl tape on both sides of the port splitter.

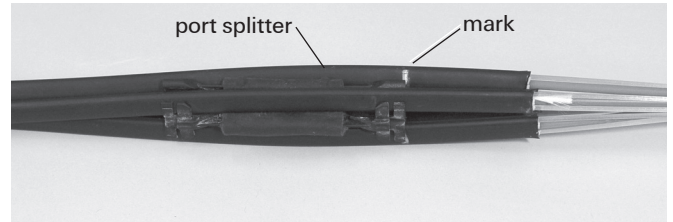

Figure 10

6. Wrap two complete layers of black felt tape around cable(s) at the end of the ring cut.
7. Cut the strength members 1.25" from the ring cut.
8. Secure the strength members to the FOSC 600 closure strength member bracket. (Figure 11)

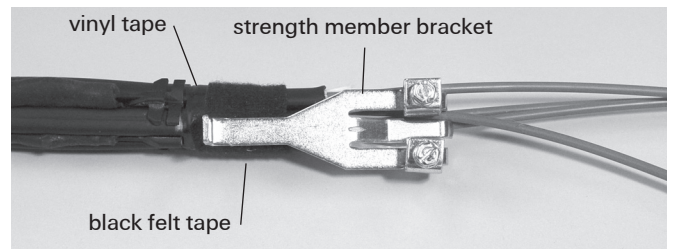

Figure 11

9. Install the strength member bracket into the FOSC 600 closure cable attachment assembly by pushing the metal tab into the slot. (Figure 12)

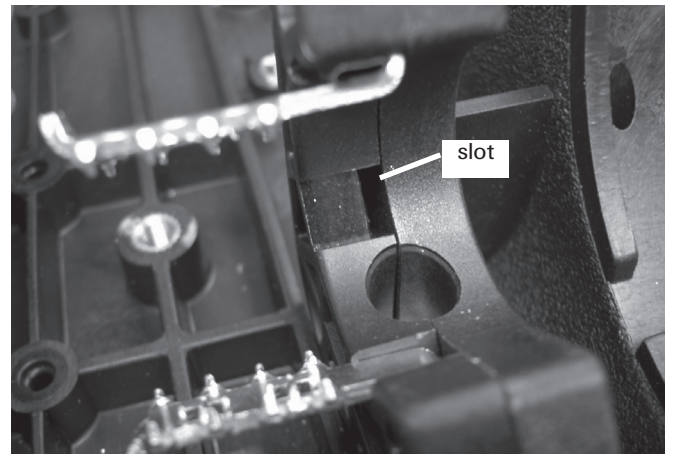

Figure 12

10. Adjust the sheath retention clips until they grip the black felt tape.
11. Install the hose clamp over the retention clips. Tighten the hose clamp such that retention bracket teeth seat fully into the black felt wrap. (Figure 13)
12. Go to Section 4.0.

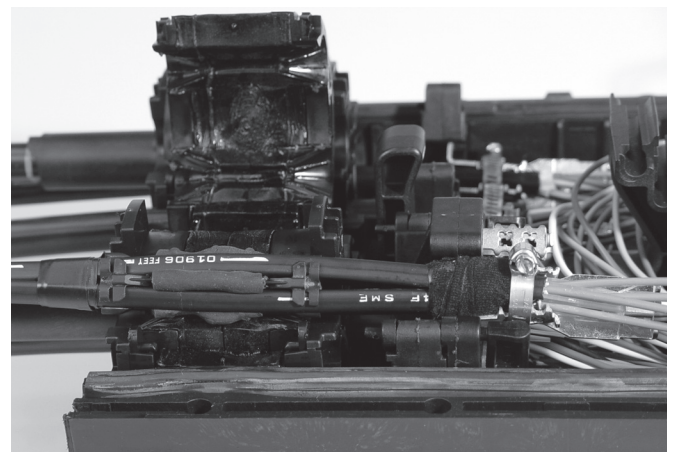

Figure 13

4.0 Sealing the Closure

1. Install gel block. Gel of the port splitter should be centered with the gel block. (Figure 14)

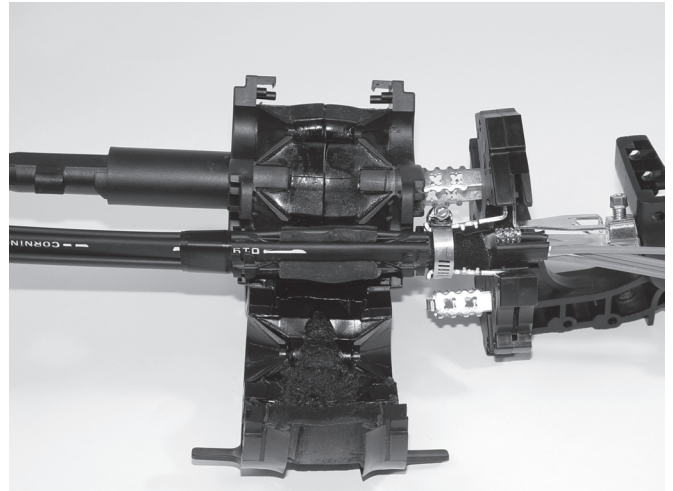

Figure 14

2. Close the gel seal. Insert yellow plugs into unused ports. (Figure 15)
3. Reinstall closure base (FOSC 450 closure) or top half of closure body (FOSC 600 closure) and tighten gel block to seal cables.



Figure 15

5.0 Adding Additional Small Cables After the Initial Installation

1. Remove the hose clamp.
2. Follow Section 3.0 of these instructions, positioning the new drop(s) and reinstall the cable in the closure.

Technical Assistance Center (TAC)
Tel.: 800.830.5056
Email: TAC.Americas@commscope.com
www.commscope.com

FOSC 450, FOSC 600, CommScope (logo), and CommScope are trademarks of the Commscope group of companies and its licensors.

The information given herein, including drawings, illustrations and schematics which are intended for illustration purposes only, is believed to be reliable. However, CommScope makes no warranties as to its accuracy or completeness and disclaims any liability in connection with its use. CommScope obligations shall only be as set forth in CommScope Standard Terms and Conditions of Sale for this product and in no case will CommScope be liable for any incidental, indirect or consequential damages arising out of the sale, resale, use or misuse of the product. Users of CommScope products should make their own evaluation to determine the suitability of each such product for the specific application.